



The Global Language of Business

Apparel and General Merchandise

Best Practice Guideline for Exchanging Product Images and Attributes

Release 4.1, April 2, 2024



Table of Contents

1	Introduction	16
1.1	Overview	16
1.2	Who Developed This Guideline?	16
1.3	Objectives	16
1.4	Scope	16
1.5	Audience	17
1.6	Document Purpose	17
1.7	Release 4.1 Summary	18
2	General Image Specifications	20
2.1	How Do I Use the Image Sections of this Guideline?	20
2.2	Still Shot Product Single Item	20
2.2.1	Product Background	20
2.2.2	Clipping Paths	20
2.2.3	Image Size	20
2.2.4	Color Mode	21
2.2.5	Up-Sizing / Interpolation	21
2.2.6	White Balance	21
2.2.7	Background	22
2.2.8	Image Examples	22
2.3	360° Imaging vs. 3D Interactive Imaging vs. 3D Modelling	23
2.4	360° Imaging	23
2.5	Detail Image	24
2.6	Montage	25
2.7	Image File Naming	25
2.7.1	Uniqueness	25
2.7.2	Non-Intelligent Structure	25
2.7.3	GDTI Naming	25
2.8	Image Meta Data	26
2.8.1	Mandatory Image Attributes	27
2.8.2	Optional Image Attributes	30
2.9	Image Naming Examples	32
2.9.1	Example 1: GDTI - Non-Intelligent Naming Convention	32
2.9.2	Example 2: GDTI - Vendor-Defined Intelligent Naming Convention	34
2.10	Supporting Documentation	37
2.10.1	Pilot Program	37
2.10.2	EDI 832 Price/Sales Catalog Transaction Set	37
2.10.3	Other Supporting Documentation	42
2.11	Frequently Asked Questions	43
2.12	Value Proposition	45
3	General Attribute Guidance	47



- 3.1 How Do I Use the Attribute Sections of this Guideline? 47
- 3.2 Product Attribute Overview Matrix by Product Category 48
- 3.3 Product Measurements..... 56
- 3.4 Core/Common Attributes..... 57
 - 3.4.1 Product..... 57
 - 3.4.2 Product Description 57
 - 3.4.3 GTIN – Global Trade Item Number 57
 - 3.4.4 Color Description 58
 - 3.4.5 GS1 US Color Code 58
 - 3.4.6 Size Description..... 58
 - 3.4.7 GS1 US Size Code..... 59
- 3.5 E-Commerce Extended Consumer Product Attributes 60
 - 3.5.1 Adhesive..... 60
 - 3.5.2 Adjustable 60
 - 3.5.3 Adjustable Strap 60
 - 3.5.4 Advertised Origin 61
 - 3.5.5 Aerosol Product 61
 - 3.5.6 Asthma/Allergy Certified 62
 - 3.5.7 Bag Type 62
 - 3.5.8 Band Type 62
 - 3.5.9 Beauty Area of Use 63
 - 3.5.10 Beauty Treatment Specialty 63
 - 3.5.11 Beauty Type..... 63
 - 3.5.12 Bedding Size 64
 - 3.5.13 Bedding Type 64
 - 3.5.14 Belt Type 64
 - 3.5.15 Benzoyl Peroxide Resistant 65
 - 3.5.16 Bill Logo Application 65
 - 3.5.17 Bill Type 66
 - 3.5.18 Boot Leg Circumference..... 66
 - 3.5.19 Boot Shaft Height 67
 - 3.5.20 Boot Shaft Type..... 67
 - 3.5.21 Boxed for Gift Giving 68
 - 3.5.22 Bra Band Type..... 68
 - 3.5.23 Bra Bust Type 68
 - 3.5.24 Bra Cup Coverage..... 69
 - 3.5.25 Bra Cup Type 69
 - 3.5.26 Bra Impact Level 69
 - 3.5.27 Bra Padding 70
 - 3.5.28 Bra Specialty Type 70
 - 3.5.29 Bra Type..... 71
 - 3.5.30 Bra Underwire 71
 - 3.5.31 Bracelet Type 71
 - 3.5.32 Brand Name..... 72



3.5.33	Care Information	73
3.5.34	Care Instructions Code	73
3.5.35	Circularity Certifications.....	73
3.5.36	Closure.....	74
3.5.37	Chemical Certifications	74
3.5.38	Coat/Jacket Type	75
3.5.39	Color Extended Description	75
3.5.40	Collar Type	75
3.5.41	Conference	76
3.5.42	Consumer Available Date	76
3.5.43	Consumer Item Depth	76
3.5.44	Consumer Item Height	77
3.5.45	Consumer Item Length.....	77
3.5.46	Consumer Item Weight.....	78
3.5.47	Consumer Item Width	79
3.5.48	Consumer Life Stage	79
3.5.49	Consumer Package Depth	80
3.5.50	Consumer Package Height	80
3.5.51	Consumer Package Width	81
3.5.52	Consumer Package Gross Weight.....	81
3.5.53	Consumer Product Capacity or Volume	81
3.5.54	Consumer Quantity of Units in Consumer Package	82
3.5.55	Control Level.....	82
3.5.56	Convertible	83
3.5.57	Cookware Type.....	83
3.5.58	Corporate/Philanthropic Certifications.....	83
	Country of Origin.....	84
3.5.59	Covered.....	84
3.5.60	Consumer Product Safety Improvement Act (CPSIA)	84
3.5.61	Crown	85
3.5.62	Cuff Type.....	85
3.5.63	Detachable Strap	85
3.5.64	Dinnerware Category	86
3.5.65	Discontinue Date	86
3.5.66	Dishwasher Safe	86
3.5.67	Does Not Contain.....	87
3.5.68	Dress Type.....	87
3.5.69	Earring Drop	87
3.5.70	Earring Type	88
3.5.71	Eyewear Type.....	88
3.5.72	Fabric or Material Code.....	89
3.5.73	Fabric or Material Description	89
3.5.74	Faux Fur.....	90
3.5.75	Features – Benefits - Marketing Message	91



3.5.76 Fiber 92

3.5.77 Fill Material 92

3.5.78 Finish 92

3.5.79 First Available Ship Date 93

3.5.80 First Order Date 93

3.5.81 Fit 93

3.5.82 Flatware Type 94

3.5.83 Formulation 94

3.5.84 Full Product Name 95

3.5.85 Fur Animal Name 95

3.5.86 Fur Country of Origin 96

3.5.87 Fur Treatment 96

3.5.88 Gauge 96

3.5.89 Gender 97

3.5.90 Global Product Classification (GPC) 98

3.5.91 Glove Type 99

3.5.92 Gold Karat 99

3.5.93 Hand Painted 100

3.5.94 Handbag Shoulder Drop 100

3.5.95 Handle Strap 100

3.5.96 Handmade 101

3.5.97 Harmonized Tariff Schedule Code 101

3.5.98 Hat Type 102

3.5.99 Hazardous Material Class Code 102

3.5.100 Hazardous Material Description 102

3.5.101 Heel Height 103

3.5.102 Heel Height Range 103

3.5.103 Heel Material 103

3.5.104 Heel Type 104

3.5.105 Holiday/Event 105

3.5.106 Hooded 105

3.5.107 Hosiery/Sock Type 105

3.5.108 Hypoallergenic 106

3.5.109 Ingredients 106

3.5.110 Inner Pack Quantity 107

3.5.111 Insulated 107

3.5.112 Jewelry Sets 107

3.5.113 Jewelry Type 108

3.5.114 Key-Active Ingredients 108

3.5.115 Knit Type 108

3.5.116 Laser Cut 109

3.5.117 Lead Time 109

3.5.118 League 110

3.5.119 Leather Animal Name 110

3.5.120 Leg Type110

3.5.121 Length Description111

3.5.122 Lined.....111

3.5.123 Lining Material.....111

3.5.124 Marked Retail Price112

3.5.125 Material Country of Origin112

3.5.126 Maternity112

3.5.127 Metal.....113

3.5.128 Metal Composition113

3.5.129 Metal Feet.....113

3.5.130 Microwave Safe114

3.5.131 Minimum Order Quantity114

3.5.132 Necklace Type114

3.5.133 Neckwear Type.....115

3.5.134 Number of Settings115

3.5.135 Occasion.....115

3.5.136 Officially Licensed116

3.5.137 Oil Free116

3.5.138 Open/Closed Toe116

3.5.139 Order Quantity Multiple117

3.5.140 Outsole Type.....117

3.5.141 Padded.....117

3.5.142 Pant / Inseam Length.....117

3.5.143 Pants/Shorts Type118

3.5.144 Panty Back Coverage118

3.5.145 Panty Type.....119

3.5.146 Platform Height119

3.5.147 Player Name119

3.5.148 Pocket Details120

3.5.149 Primary Detail Application120

3.5.150 Primary Detail Logo.....120

3.5.151 Primary Detail Placement.....121

3.5.152 Primary Detail Size121

3.5.153 Primary Detail Type.....121

3.5.154 Primary Motif Theme122

3.5.155 Prop 65122

3.5.156 Raw Materials Certifications122

3.5.157 Refillable123

3.5.158 Re-Orderable.....123

3.5.159 Responsible Manufacturing.....124

3.5.160 Reversible.....124

3.5.161 Ring Type124

3.5.162 Rug Type125

3.5.163 Scarf Type126

3.5.164 Scent Type.....	126
3.5.165 Seams.....	126
3.5.166 Secondary Detail Application	127
3.5.167 Secondary Detail Logo.....	127
3.5.168 Secondary Detail Placement.....	127
3.5.169 Secondary Detail Size.....	128
3.5.170 Secondary Detail Type.....	128
3.5.171 Secondary Motif Theme	128
3.5.172 Selling Channel.....	129
3.5.173 Shape	129
3.5.174 Shapewear Type.....	129
3.5.175 Shippable Package/Carton	130
3.5.176 Shoe Style	131
3.5.177 Shoe Type	131
3.5.178 Skin Type	131
3.5.179 Skirt Type.....	132
3.5.180 Sleepwear Type.....	133
3.5.181 Sleeve Measurement.....	133
3.5.182 Sleeve Type	133
3.5.183 Slip Split.....	134
3.5.184 Slip Type	134
3.5.185 Sole Type	135
3.5.186 Social Certifications.....	135
3.5.187 Special Embellishment.....	135
Special Handling Code	136
3.5.188 Special Item Code.....	136
3.5.189 SPF Rating	136
3.5.190 Sport.....	137
3.5.191 Stay Cool Handle	138
3.5.192 Steamable	138
3.5.193 Stone Details.....	138
3.5.194 Strap Placement	139
3.5.195 Stretch	139
3.5.196 Supplier Suggested Retail Price	139
3.5.197 Supplemental Circularity Certifications.....	140
3.5.198 Supplemental Corporate/Philanthropic Certifications.....	140
3.5.199 Supplemental Packaging Certifications.....	140
3.5.200 Supplemental Raw Materials Certifications	141
3.5.201 Supplemental Traceability Programs.....	141
3.5.202 Supplier Wholesale Price.....	141
3.5.203 Supply Type.....	142
3.5.204 Support Level.....	142
3.5.205 Sustainable Materials	142
3.5.206 Sustainable Packaging.....	143

3.5.207	Sweater/Pullover Type.....	143
3.5.208	Swim Bottom Type.....	144
3.5.209	Swim Cover-up Type.....	144
3.5.210	Swim One-piece Type.....	144
3.5.211	Swim Top Type.....	145
3.5.212	Tableware Type.....	145
3.5.213	Tag.....	145
3.5.214	Team Name.....	146
3.5.215	Third Detail Application.....	146
3.5.216	Third Detail Logo.....	146
3.5.217	Third Detail Placement.....	147
3.5.218	Third Detail Size.....	147
3.5.219	Third Detail Type.....	147
3.5.220	Third Motif Theme.....	148
3.5.221	Toe Shape.....	149
3.5.222	Toe Style.....	150
3.5.223	Towel Type.....	150
3.5.224	Vendor Collection Name.....	151
3.5.225	Waist Rise.....	151
3.5.226	Waistband Type.....	151
3.5.227	Warranty Description.....	152
3.5.228	Watch Band Width.....	152
3.5.229	Watch Case Shape.....	152
3.5.230	Watch Case Size.....	153
3.5.231	Water Repellant.....	153
3.5.232	Wrinkle Resistant.....	154
3.6	GS1 Extended Attribute Code Lists.....	154
3.6.1	Adjustable Strap Code List.....	154
3.6.2	Advertised Origin Code List.....	154
3.6.3	Bag Type Code List.....	155
3.6.4	Band Type Code List.....	155
3.6.5	Beauty Area of Use Code List.....	156
3.6.6	Beauty Treatment Specialty Code List.....	156
3.6.7	Beauty Type Code List.....	156
3.6.8	Bedding Size Code List.....	158
3.6.9	Bedding Type Code List.....	159
3.6.10	Belt Type Code List.....	159
3.6.11	Bill Logo Application Code List.....	159
3.6.12	Bill Type Code List.....	159
3.6.13	Boot Shaft Type Code List.....	159
3.6.14	Bra Band Type Code List.....	160
3.6.15	Bra Bust Type Code List.....	160
3.6.16	Bra Cup Coverage Code List.....	160
3.6.17	Bra Cup Type Code List.....	161



3.6.18 Bra Impact Level Code List.....161

3.6.19 Bra Padding Code List.....162

3.6.20 Bra Specialty Type Code List162

3.6.21 Bra Type Code List.....162

3.6.22 Bracelet Type Code List163

3.6.23 Care Instructions Code List163

3.6.24 Chemical Certifications Code List163

3.6.25 Closure Code List.....163

3.6.26 Coat/Jacket Type Code List165

3.6.27 Collar/Neck Type Code List165

3.6.28 Conference Code List.....166

3.6.29 Consumer Life Stage Code List167

3.6.30 Control Level Code List.....167

3.6.31 Cookware Type Code List.....168

3.6.32 Corporate/Philanthropic Certifications Code List168

3.6.33 Crown Code List168

3.6.34 Cuff Type Code List.....169

3.6.35 Dinnerware Category Code List.....169

3.6.36 Dress Type Code List.....170

3.6.37 Earring Type Code List.....170

3.6.38 Eyewear Type Code List.....171

3.6.39 Fabric or Material Code List171

3.6.40 Fiber Code List175

3.6.41 Fill Material Code List176

3.6.42 Finish Code List177

3.6.43 Fit Code List.....177

3.6.44 Flatware Type Code List.....177

3.6.45 Formulation Code List.....178

3.6.46 Fur Animal Name Code List178

3.6.47 Fur Treatment Code List178

3.6.48 Gauge Code List179

3.6.49 Gender Code List179

3.6.50 Glove Type Code List.....179

3.6.51 Hat Code List179

3.6.52 Heel Height Range Code List180

3.6.53 Heel Material Code List.....180

3.6.54 Heel Type Code List180

3.6.55 Holiday/Event Code List.....180

3.6.56 Hosiery/Sock Type Code List181

3.6.57 Jewelry Sets Code List.....181

3.6.58 Jewelry Type Code List181

3.6.59 Knit Type Code List181

3.6.60 League Code List182

3.6.61 Leg Type Code List.....182

3.6.62	Leather Animal Name Code List	183
3.6.63	Length Description Code List	184
3.6.64	Lined Code List.....	184
3.6.65	Lining Material Code List.....	185
3.6.66	Metal Code List.....	185
3.6.67	Metal Composition Code List.....	186
3.6.68	Necklace Type Code List	186
3.6.69	Neckwear Type Code List	186
3.6.70	Number of Settings Code List	186
3.6.71	Occasion Code List.....	187
3.6.72	Outsole Type Code List.....	187
3.6.73	Open/Closed Toe Code List	188
3.6.74	Pants/Shorts Type Code List.....	188
3.6.75	Panty Back Coverage Code List.....	188
3.6.76	Panty Type Code List.....	188
3.6.77	Primary Detail Application Code List	189
3.6.78	Primary Detail Placement Code List	190
3.6.79	Primary Detail Size Code List.....	190
3.6.80	Primary Detail Type Code List.....	190
3.6.81	Primary Motif Theme Code List	191
3.6.82	Raw Materials Certifications Code List.....	191
3.6.83	Ring Type Code List	192
3.6.84	Rug Type Code List	192
3.6.85	Scarf Type Code List	192
3.6.86	Scent Type Code List.....	193
3.6.87	Seams Code List	194
3.6.88	Secondary Detail Application Code List	194
3.6.89	Secondary Detail Placement Code List	195
3.6.90	Secondary Detail Size Code List.....	195
3.6.91	Secondary Detail Type Code List.....	195
3.6.92	Secondary Motif Theme Code List	196
3.6.93	Selling Channel Code List.....	196
3.6.94	Shape Code List.....	196
3.6.95	Shapewear Type Code List	196
3.6.96	Shoe Style Code List	197
3.6.97	Shoe Type Code List.....	198
3.6.98	Skin Type Code List.....	198
3.6.99	Skirt Type Code List	198
3.6.100	Sleepwear Type Code List	199
3.6.101	Shoe Type Code List.....	199
3.6.102	Skin Type Code List.....	200
3.6.103	Skirt Type Code List	200
3.6.104	Sleepwear Type Code List	200
3.6.105	Sleeve Type Code List	201



3.6.106 Slip Type Code List201

3.6.107 Social Certifications Code List201

3.6.108 Sole Type Code List.....201

3.6.109 Special Embellishment Code List202

3.6.110 SPF Rating Code List203

3.6.111 Sport Code List.....203

3.6.112 Strap Placement Code List203

3.6.113 Supplemental Circularity Certification Code List204

3.6.114 Supplemental Corporate/Philanthropic Code List204

3.6.115 Supplemental Packaging Certifications Code List.....204

3.6.116 Supplemental Raw Materials Certifications Code List204

3.6.117 Supplemental Traceability Programs Code List.....205

3.6.118 Supply Type Code List205

3.6.119 Support Level Code List205

3.6.120 Sweater/Pullover Type Code List.....206

3.6.121 Swim Bottom Type Code List.....207

3.6.122 Swim Cover Up Type Code List207

3.6.123 Swim One-Piece Type Code List.....207

3.6.124 Swim Top Type Code List.....208

3.6.125 Tableware Type208

3.6.126 Third Detail Application Code List.....209

3.6.127 Third Detail Placement Code List.....210

3.6.128 Third Detail Size Code List210

3.6.129 Third Detail Type Code List210

3.6.130 Third Motif Theme Code List.....211

3.6.131 Toe Shape Code List.....211

3.6.132 Toe Style Code List211

3.6.133 Towel Type Code List211

3.6.134 Waist Rise Code List.....211

3.6.135 Waistband Type Code List212

3.6.136 Watch Case Shape Code List212

3.6.137 Water Repellent Code List212

3.7 Code List Instructions213

3.8 Recommended EDI Map for Core and Extended Product Information Exchange214

3.9 GS1 US Standard Spreadsheet for Product Information Exchange251

4 Resources 252

4.1 Links to ISO Country Code Information252

4.2 Link to GS1 Product Image Specification Standard252

4.3 Glossary252

About GS1

GS1® is a neutral, not-for-profit, global organization that develops and maintains the most widely-used supply chain standards system in the world. GS1 Standards improve the efficiency, safety, and visibility of supply chains across multiple sectors. With local Member Organizations in over 110 countries, GS1 engages with communities of trading partners, industry organizations, governments, and technology providers to understand and respond to their business needs through the adoption and implementation of global standards. GS1 is driven by over a million user companies, which execute more than six billion transactions daily in 150 countries using GS1 Standards.

About GS1 US

GS1 US®, a member of GS1 global, is a not-for-profit information standards organization that facilitates industry collaboration to help improve supply chain visibility and efficiency through the use of GS1 Standards, the most widely-used supply chain standards system in the world. Nearly 300,000 businesses in 25 industries rely on GS1 US for trading-partner collaboration that optimizes their supply chains, drives cost performance and revenue growth while also enabling regulatory compliance. They achieve these benefits through solutions based on GS1 global unique numbering and identification systems, barcodes, Electronic Product Code (EPC®)-based RFID, data synchronization, and electronic information exchange. GS1 US also manages the United Nations Standard Products and Services Code® (UNSPSC®).

Document Summary

Document Item	Current Value
Document Title	Best Practice Guideline for Exchanging Product Images and Attributes
Date Last Modified	April 2024
Document Description	This guideline provides detailed guidance on how to create, manage, and supply product images and data attributes for use in commerce applications across retail operations.

Log of Changes

Release Number – Date	Changes
Release 3.0	This document combines and updates content previously published in the Exchanging Extended Attributes for E-Commerce and Best Practice for Product Image Exchange between Trading Partners guidelines. By placing all information into one document, these items are easier to search, use, and update in the future.
Release 3.1 – May 2018	<ul style="list-style-type: none"> ■ 3.3.13 Occasion update ■ 3.5.15 Boot Shaft measurement correction ■ 3.5.21 Care Instructions Code addition ■ 3.5.130 Prop 65 changes ■ 3.6.16 Corrected Young Adult code value ■ 3.6.52 Corrected Work/Uniform code value ■ 3.8.2 Added Prop65 example ■ 3.9 Added Prop 65 EDI information ■ Errata correction
Release 3.2 – March 2019	<ul style="list-style-type: none"> ■ 3.5.161 Added "Steamable" ■ 3.9 Added example of Player Names
Release 3.3 – July 2019	<ul style="list-style-type: none"> ■ Added new closure value (Elastic Lace w/ Toggle-GM03CLOSET)

<p>Release 3.4 – September 2020</p>	<ul style="list-style-type: none"> ■ Added 24 new attributes, bringing the total available attributes to 217. ■ Added/removed/modified some attribute values for clarity ■ Reworked some attribute names and removed values
<p>Release 4.0 – December 2022</p>	<ul style="list-style-type: none"> ■ Added verbiage to section 3.1 to clarify essential attributes ■ Added 11 new attributes bringing the total available attributes to 228 ■ Listed associated GPC code values for essential attributes ■ Added images to some attributes for clarity ■ Added/Modified some attribute values for clarity
<p>Release 4.1 - April 2024</p>	<ul style="list-style-type: none"> ■ Added new sustainability certification attributes ■ Added new Beauty Type attribute ■ Added additional code values to Beauty Treatment Specialty ■ Classified all attributes as either essential or not ■ Updated GPC essential attribute matrix to include beauty ■ Updated Attribute Template spreadsheet with new attributes

The GS1 System of Standards

The GS1 System of Standards is an integrated suite of global standards that provides for accurate identification and communication of information regarding products, assets, services, and locations. Using GS1 Identification Numbers, companies and organizations around the world are able to globally and uniquely identify *physical things* like trade items, assets, logistic units and physical locations, as well as *logical things* like corporations or a service relationship between provider and recipient. When this powerful identification system is combined with GS1 barcodes, eCom, EPC®-enabled item-level /RFID, and the Global Data Synchronization Network™ (GDSN®), the connection is made between these physical or logical things and the information the supply chain needs about them.

About the GS1 Apparel and General Merchandise Initiative

The GS1 US Apparel and General Merchandise Initiative serves as a strategic effort in which retailers, marketplaces, brand owners, suppliers, manufacturers, industry trade associations, solution providers, and academia voluntarily join to assist in helping the retail industry drive the adoption and use of the GS1 Standards.

To learn more about the Initiative, visit:

www.gs1us.org/ApparelGM

Executive Summary

Images and Attributes are crucial to organizations seeking to provide consumers with a consistent selling experience across all distribution (omni) retail channels. Consumers shopping via multiple channels have created an ever-increasing demand for product images and data attributes in the Apparel and General Merchandise industry. With the growth of internet marketing and sales, the use of images and extended product attributes has increased dramatically. However, the lack of standards has made the sharing of this information between trading partners quite challenging. Without standards, conflicting trading partner requirements about how attributes and images should be captured, named, and shared had made managing and exchanging this information difficult and inefficient.

Standard business processes are needed to increase efficiencies and minimize costs related to image and attribute exchange. For example:

- Harmonization of required data exchange practices helps reduce individual mapping from multiple sources to a single process, thus reducing errors and duplication.
- Image naming utilizing a global standardized convention allows for a higher level of security against inadvertent over-writing.
- Providing clear definitions and examples of attributes helps enable trading partners to consistently exchange accurate and complete data.

Therefore, to address the lack of minimum attribute and image requirements among Apparel and General Merchandise trading partners, GS1 US® assembled industry stakeholders and experts to develop recommendations for how to apply GS1 Standards for product images and data attributes associated with Apparel and General Merchandise products.

1 Introduction

1.1 Overview

This Application Guideline was prepared by the GS1 US Apparel and General Merchandise Initiative Product Images and Data Attributes Workgroup to assist trading partners with the use of GS1 Standards for product images and data attributes. It provides detailed guidance on how to create, manage, and supply product images and data attributes for use in commerce applications across retail operations. Implementation of this guideline is voluntary. Trading partner relationships will determine the scope and timing of individual deployments.

 **Note:** As with all GS1 Standards and solutions, this guideline is voluntary, not mandatory. It should be noted that use of the words “must”, and “require”, “mandatory” and “essential” throughout this document relate exclusively to technical recommendations for the proper application of the standards to support the integrity of your implementation.

1.2 Who Developed This Guideline?

This Guideline was developed by the *GS1 US Product Images & Data Attributes Workgroup*. The workgroup includes representatives from leading North American general merchandise and apparel vendors, retailers, and solution providers. This group of companies represents a broad spectrum of product categories within the retail industry and includes companies large and small.

1.3 Objectives

Images Guidelines:

To identify, develop, and document standardized methods to name, identify, manage, locate, and acquire images for Apparel and General Merchandise brand owners, manufacturers, suppliers, retailers, e-tailers, marketplaces, and solution providers.

Attributes Guidelines:

To identify, develop, and document standardized methods for exchanging extended attributes between Apparel and General Merchandise brand owners, manufacturers, suppliers, retailers, e-tailers, marketplaces, and solution providers. This data extends beyond the traditional supply chain information already exchanged between buyers and sellers and includes the essential product information that end-consumers will need throughout the purchase cycle.

1.4 Scope

The scope of this document is image and attribute specifications for internet/e-commerce applications within Apparel, Footwear, and General Merchandise categories. The guidance provided focuses on those product images and attributes that are essential for consumers to make purchasing decisions, and which are not already part of the body of data that may be exchanged between buyers and sellers during the new item introduction (i.e., listing) business process. Section 3 shows a list of core product attributes that are currently exchanged during the listing process. Guidance is also provided for attributes that are needed by buyers and sellers to support core supply chain functions.

This document focuses on the images and extended product attributes deemed essential for any initial e-commerce implementation. The document serves as a starting point for all trading partners to analyze their current internal capabilities and begin planning for the exchange of incremental (i.e., extended) consumer product images and attributes.

1.5 Audience

This document is designed to be used by both suppliers and retailers, as well as establishes a framework for third-party providers that may service either trading partner. The guidance provided is applicable to all companies' trading products in the general merchandise and apparel sector. This includes, but is not limited to, cosmetics, jewelry, footwear, fashion accessories, apparel and sportswear, sporting goods, home fashion, and small appliances. This document can be used by companies throughout North America. The primary audience is the business analyst who must determine which product information must be sourced, validated, and syndicated (shared) within the enterprise and between trading partners.

1.6 Document Purpose

The purpose of this guideline is to define best practices to help:

- Create a single set of images that can be used by all of trading partners
- Promote image quality, size, shape, etc.
- Indicate the level to which an image should be applied (i.e., to all Stock Keeping Units (SKUs) within a style, style/color, or GTIN® (Global Trade Item Number®))
- Uniquely name images to prevent overlays of images by users
- Indicate image location as a URL for retrieval by trading partners

The purpose of the attributes portion of this guideline is to define best practices to support:

- Consistent brand representation
- Clear definitions of attributes
- Attribute definitions that are essential to each product classification
- Harmonious product information specifications
- Faster speed to market (time-to-revenue)
- Streamlined attribute exchange (optimized data sharing)
- More product detail for e-Commerce consumers



Note: To help support communication about and adoption of GS1 Standards for Product Images and Data Attributes, two template letters were developed: [Retailer Template Letter](#) and a [Supplier Template Letter](#). These letters are intended to help mid-level buyers and managers advocate the benefits of using product information standards in order to secure senior management buy-in and/or sponsorship.

1.1 Release 4.0 Summary

Attribute	Changes
Belt Type	New Attribute
Glove Type	New Attribute
Leather Animal Name	New Attribute
Responsible Manufacturing	New Attribute
Scarf Type	New Attribute
Swim Bottom Type	New Attribute
Swim Cover-up Type	New Attribute
Swim One-piece Type	New Attribute
Swim Top Type	New Attribute
Sustainable Materials	New Attribute
Sustainable Packaging	New Attribute
Toe Shape/Toe Style	Broken out into two separate attributes
Gender	Updated attribute for clarity
Fabric Code List	Added "Glitter" as a code value
Selling Type Code List	Added "Drop ship" as a code value

1.2 Release 4.1 Summary

Attribute	Changes
Beauty Type	New attribute and code values
Beauty Treatment Specialty	Additional code values



Chemical Certifications	New attribute and code values
Raw Materials Certifications	New attribute and code values
Corporate/Philanthropic Certifications	New attribute and code values
Social Certifications	New attribute and code values
Circularity Certifications	New attribute and code values
Supplemental Circularity Certifications	New attribute and code values
Supplemental Packaging Certifications	New attribute and code values
Supplemental Corporate/Philanthropic Certifications	New attribute and code values
Supplemental Traceability Programs	New attribute and code values
Supplemental Raw Materials Certifications	New attribute and code values
Toe Style	Updated code value for Other

2 General Image Specifications

2.1 How Do I Use the Image Sections of this Guideline?

- Review *Section 2.2* which provides guidance on Still Shot Product for Single Items, the most common type of image provided.
- Read *Section 2.3* to review 360 and Montage images.
- Read *Section 2.4* discussing Image File Naming conventions and standards.
- *Section 2.5* to review Meta Data of images, including Mandatory and Optional information when trading image data with your business partners.
- After you have read and shared this guideline with your trading partner(s), discuss possible enhancements to your existing data feeds. All parties will need sufficient time to retrofit existing information transfers (through spreadsheet, EDI, etc.).

2.2 Still Shot Product Single Item

It is understood that there will be instances where photography, other than “product” photography, will be needed. Also, situations may arise where product shots are needed at a size or resolution that exceeds the above-mentioned standards. In these cases, it will be up to the customer to either originate the photography themselves or work out arrangements with the vendor to supply said photography on an “as-needed” basis. ALL supplied photography should conform to the guidelines listed below.



Note: Marketing Images applies to both digital images captured through use of a digital camera (or other digital imaging devices) as well as rendered images. Rendered images are computer-generated images which can be comprised of graphic renderings and/or digital images to create a lifelike product semblance.

2.2.1 Product Background

Where product images have a clipping path, applied all backgrounds must be knocked out to white (RGB 255/255/255).

2.2.2 Clipping Paths

A “*clipping path*” is a hard-edged mask that hides unwanted image elements. Clipping paths are typically used to hide the background of an image or may be used to shape an image into non-rectangular shapes, making the masked portions transparent. Clipping paths can be created in graphics programs then exported with an image as an embedded path or alpha channel, or they can be drawn directly in some page layout applications.

- All images shall contain a clipping path in order for the product to be silhouetted and/or have proprietary backgrounds applied.
- To facilitate batch automation, it is very important that the clipping path be named “Path 1”.
- Default flatness setting shall be 1-device pixels.

2.2.3 Image Size

- The minimum image size and resolution shall be as per type in Table 2.1 (below).
- The image should be square – not rectangle.
- Image size should be a 1:1 square aspect ratio (e.g., 900 pixels x 900 pixels).

- Image Positioning: The center of the item shall be centered in the image frame with a maximum of 5% whitespace permitted on either end of the largest image axis (total of 10%).

Table 2-1 Image Size and Format

Image type	Size range (pixels)	Resolution	Format	Color mode	Clipping path
Still shot product single item	2400x2400 – 4800x4800	300 ppi	JPG (preferred) or PNG	RGB	Required
Still shot product single item with Supporting Elements in Image	2400x2400 – 4800x4800	300 ppi	JPG (preferred) or PNG	RGB	Required
360° Imaging	400x400 (minimum)	150 ppi	JPG/PNG	RGB	Optional
Detail Image	300x300 – 4200-4200	300 ppi	JPG/PNG/GIF (JPG recommended)	RGB	Required
Montage Image	2400x2400 – 4800x4800	300 ppi	LZW Compressed TIFF	RGB	Required



Note: The ICC profile or exact color space must be known and defined. The preference for storage of the source file is RGB 8 bit per channel.

2.2.4 Color Mode

The Color Mode is RGB (Red Green Blue) optimized for monitors and viewing systems and set at 8 bits per channel.

2.2.5 Up-Sizing / Interpolation

- No alpha channel or layers, guides, or rulers.
- No bubbles, fingerprints, or Newton rings from scans.
- No transfer functions or postscript color management.
- No signatures, 'finger printing,' or visible watermarks.
- No compression artifacts.
- No interpolation (resizing up).
- No scanning from printed pages.
- No evidence of dust or scratches.
- No manufactured shadows.
- Moire Patterns shall be minimized.

2.2.6 White Balance

- No color casts. Color should be as rich, vibrant, and eye-catching as possible.
- Color shall be balanced overall and not "blown out" in highlights. Flesh tones and grass should be realistic and lifelike. Reflections should also be realistic. (These requirements may be image state/style dependent).
- Shadows shall be realistic and neutral.
- Retouching shall be as seamless and undetectable as possible and be convincing at a minimum of 200% magnification (i.e. removal of expiration/best before dates).
- Colors shall match to product Pantone Matching System (PMS) colors (list to be provided by designer). Pantone is a set of standard colors for printing, each of which is specified by a single number.

- If PMS color is not available or if color is proprietary, users must either match as closely as possible to color swatches or the actual RGB breakdown must be provided.

2.2.7 Background

- All backgrounds must be knocked out to white (RGB 255/255/255).
- All images, regardless of color, must have a close-cropped path defined. This path is a graphic tool which allows for the application of a varied background to better showcase the item imaged.

2.2.8 Image Examples

Imaging Series 1

Imaging Series 1 demonstrates the centering requirement. Image 1a is correct, centered both vertically and horizontally in the image frame. Image 1b is incorrect, centered horizontally but not vertically.

Figure 2-1 Imaging Series 1: Centering Requirement

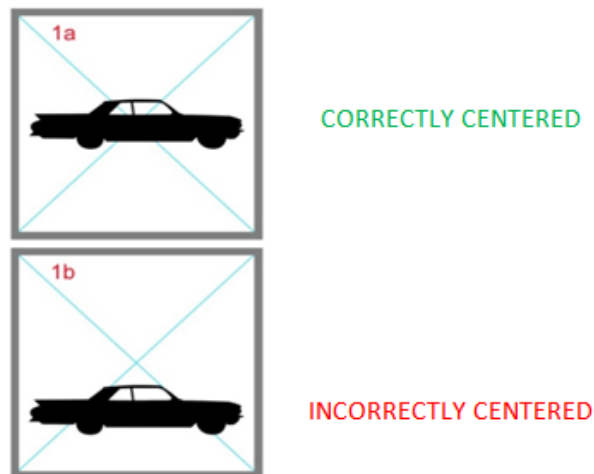

Imaging Series 2

Imaging Series 2 demonstrates the maximum white space border. Image 2a is correct, with the correct amount of white space top and bottom (relative to the image primary axis). Image 2b is incorrect, exceeding the maximum allowable border.

Figure 2-2 Imaging Series 2: Maximum White Space Border



2.3 360° Imaging vs. 3D Interactive Imaging vs. 3D Modelling

Because these terms can often be misapplied, a general description of each of these digital entities are provided below:

- 360-degree (360°) imaging is product photography on a single axis – the product rotates on a single axis while the camera takes pictures at specified degree intervals. The images taken of a product can be associated together in a viewer to allow for an interactive image to be created that can be rotated by the user to replicate a sense of a physical product in a digital setting.
- 3D product interactive imaging is 360° product photography on more than one axis. When the images are edited, formatted, and associated to the viewer, the consumer can rotate the product along the sides and the top – this is a 3D interactive image.
- 3D modelling (also known as a 3D rendered model) is a process whereby a digital framework is created, and then graphic layers are applied or created to 'build' a virtual object which, through software, can be rotated in any direction to allow for an interactive object to be created that can be manipulated by the user.

2.4 360° Imaging

360° imaging is product photography on a single axis – the product rotates on a single axis while the camera takes pictures at specified degree intervals.

■ Number of Images:

- Minimum of 24 images
- Maximum of 360 images



Note: Larger items would benefit from an increased number of images to support fluidity of motion. Industry applications should be considered for total image count.

- **Direction of Rotation:**
 - The direction of rotation for image capture should be clockwise.
 - Direction is determined from observing the sequence of images of the item from a centre top vantage point, looking down upon the object.
- **Image Sequence (Arc position):**
 - The image sequence should be identified in the image name or associated data.
 - The sequence should follow the stitching sequence used to complete the 360° pattern or mapping.

Figure 2-3 Example of 3D Imaging

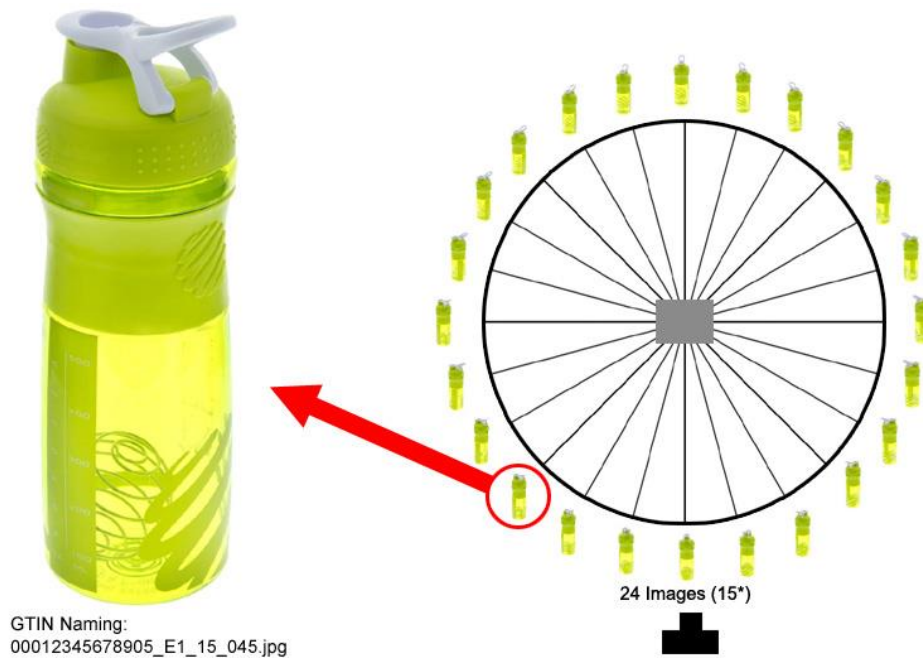

2.5 Detail Image

A detail image is a photo, line art, or other graphic representation of a specific product characteristic. It is used to highlight a specific detail or characteristic of an item.

Figure 2-4 Detail Image

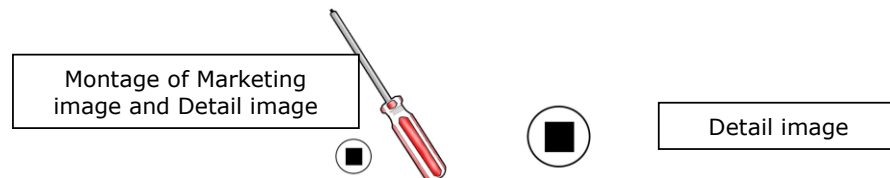

2.6 Montage

A Montage is the physical over layering of distinct images to create a final digital image. This process allows for a composite to be created with the future possibility of reconstruction without having to return to studio for correction, should an element be added or removed.

2.7 Image File Naming

A non-intelligent unique naming convention is recommended which identifies who the image is from, the type of image, and provides a unique reference to link additional information/content within a data system. The GS1 Global Document Type Identifier (GDTI) was selected as the recommended naming structure to be utilized.

- The recommended course of action is a unique, non-intelligent GDTI naming structure. This does not mean that a structured GDTI format is not allowed. This provides suppliers a margin of flexibility with regard to the naming structure to better integrate with their current systems.
- Although GDTI is the recommended best practice, other proprietary naming structures can be utilized if agreed upon between trading partners.



Important: Verify any character restrictions of your operating systems and Electronic Data Interchange (EDI) systems when naming your image file. It is recommended that you use only alphanumeric characters.

2.7.1 Uniqueness

A globally unique naming structure shall be implemented to assure cross functionality within an organization's document management system. This will also increase the level of stability within an image collection point. Key questions to consider:

- Does the naming structure allow for multiple images of the same base elements without impacting current or future image storage practices?
- Will the naming structure work with existing systems?

2.7.2 Non-Intelligent Structure

With a non-intelligent naming structure, there will be less chance of improper naming practices and a smaller time gap for standard integration.

2.7.3 GDTI Naming

The GDTI is the Identification Key comprised of the GS1 Company Prefix, an owner-assigned Document Type identifier, a Check Digit, and the optional serial component (1 to 17 alpha numeric characters). This identifier can be used to access database information if required for document control purposes. The GDTI is assigned for the lifetime of the document type and may be barcoded using Application Identifier (253).

Figure 2-5 GDTI Construction

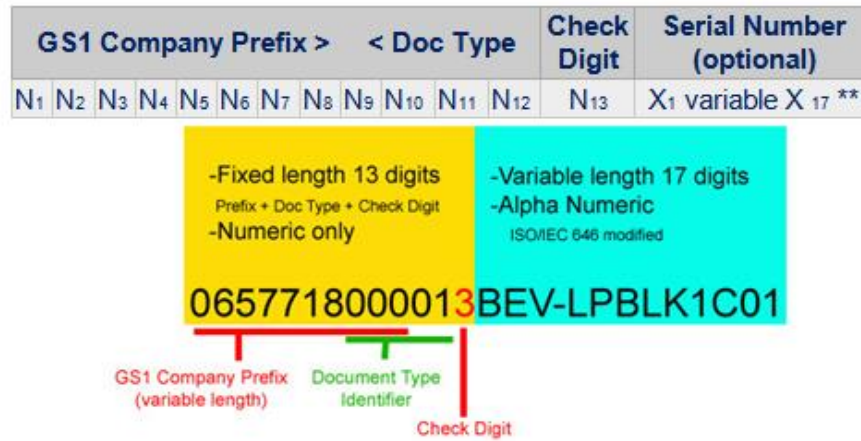

The GDTI is composed of a GS1 Company Prefix, a Document Type, a Check Digit, and the optional serial component (1 to 17 alpha numeric characters).

At its simplest, the Document Type represents a set of documents with similar attributes, and the Document Type, together with the Serial Number, represents an instance of a document with those attributes. The first 12 digits of a GDTI are assigned in the same manner as GTIN and GLN (Global Location Number): the GS1 Company Prefix and the Document Type reference are concatenated to make a 12-digit number. Although GDTI, GTIN, and GLN are all GS1 Identification Keys and are based on similar assignment structure, there is no inherent correlation between the GDTI and any other GS1 Identification Key.

✓ Note: Use your GS1 Company Prefix, not your UPC Company Prefix. It is important to include this in the creation of the GDTI structure.

Figure 2-6 Example of GDTI and U.P.C. Symbology



(Refer to [image naming examples.](#))

2.8 Image Meta Data

This section reviews specific data components related to a product image. The data may be conveyed between parties using any agreed-upon methods, including paper (e.g., a spreadsheet) or electronically (e.g., EDI, eXtensible Mark-up Language (XML), etc.). Refer to the [detailed sample view of GS1 US Apparel and General Merchandise Attribute Template](#) for additional implementation guidance and X12 EDI mapping guidance for the 832 Price/Sales Catalog transaction set.

2.8.1 Mandatory Image Attributes

2.8.1.1 Supplier Identifier/Number

Definition: Identifier used to identify the supplier (e.g., BCT ID (U.P.C. Catalog Number); EDI Sender ID; GLN; proprietary identifier; etc.)

Implementation Guidance:

- Mandatory
- Alphanumeric field
- Maximum of 15 characters

2.8.1.2 Image Product Identifier

Definition: Attribute(s) that provides the product identification

Implementation Guidance:

- Mandatory
- Style
- Style + Color Description + Color Code
- Style + Color Description + Color Code + Size Description + Size Code
- GTIN

2.8.1.3 Image Media Type/Form Function/Facing/File Type

Definition: Basic descriptive information about the image

Implementation Guidance:

- Mandatory
- 4-part component data element comprised of the parts shown in the table below

Table 2-2 Image Media Type/Form Function/Facing/File Type

Part	Values
Part 1 – Multi-Media Object Type	<ul style="list-style-type: none"> ■ SI (Still Image)
Part 2 – Image Form/Function	<ul style="list-style-type: none"> ■ INT (Internet) or ADV (Advertising/Marketing)
Part 3 – Image Facing	<ul style="list-style-type: none"> ■ PRI - Primary ■ VFI - Front ■ VIK - Back ■ VIS - Side ■ SDL - Side Left ■ SDR - Side Right ■ VIB - Bottom ■ VIT - Top
Part 4 – Image File Type	<ul style="list-style-type: none"> ■ JPG

Figure 2-7 GS1 Facing Indicators – General Merchandise

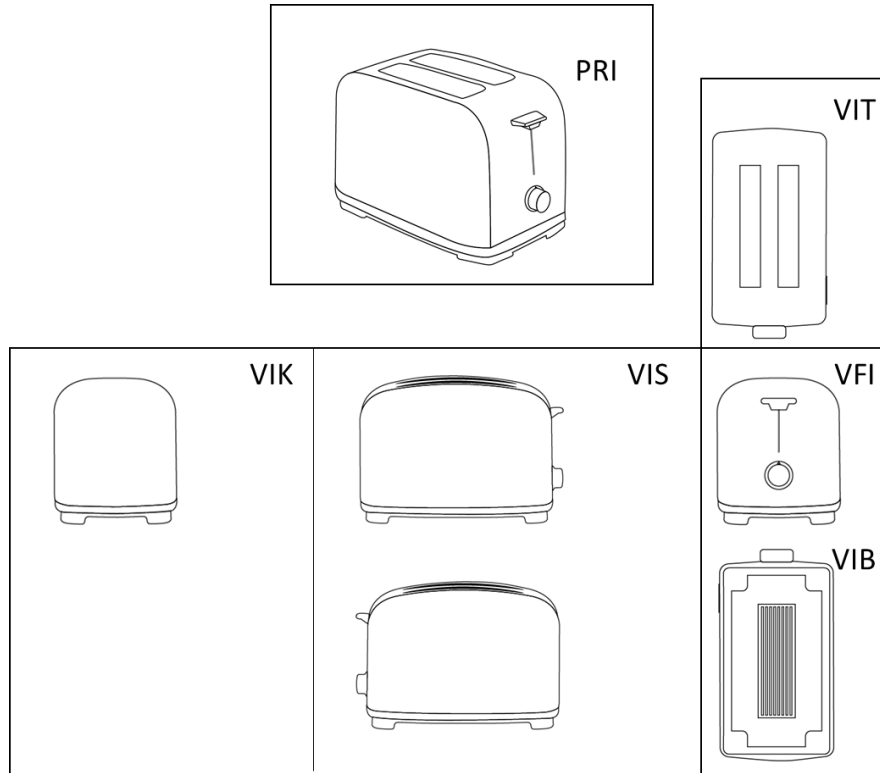
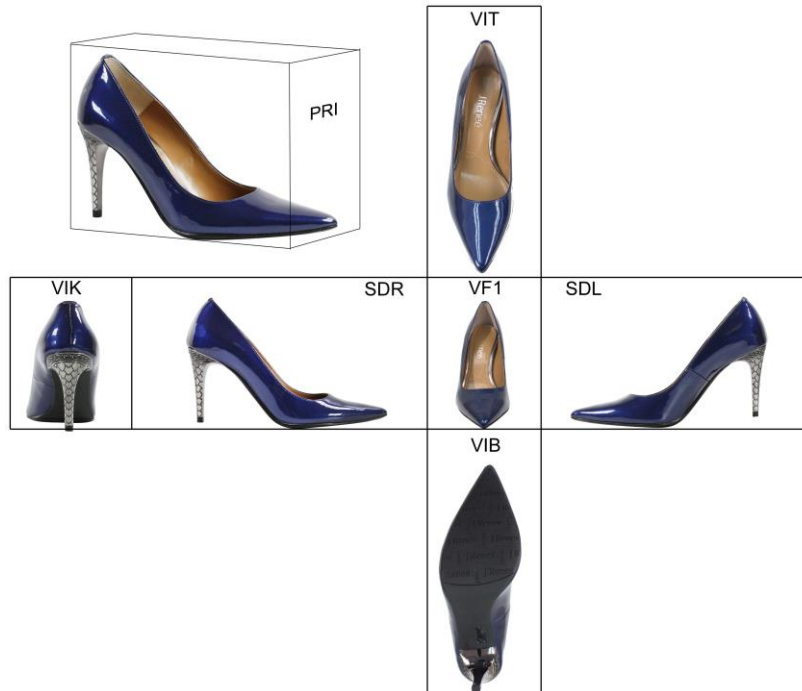

Figure 2-8 GS1 Facing Indicators – Footwear



2.8.1.4 Image Application Level Indicator

Definition: Indicator of the level to which the image is applicable

Implementation Guidance:

- Mandatory
- Valid options are -
 - Image applies to Style Level – Use 'PID'
 - Image applies to Style/Color Level – Use 'CLR'
 - Image applies to the GTIN Level – Use 'UPC' (image at size level)

2.8.1.5 Image Location Type

Definition: Type of location where the image can be retrieved

Implementation Guidance:

- Mandatory
- Valid options are -
 - URL – Indicates the Image will be retrieved via URL (example: http:// https://)
 - FTP – Indicates the Image will be retrieved via FTP (example: ftp:// sftp:// ftps://)
 - LMI - Local Media Identifier (such as CD, DVD, or other portable storage device) with the directory path

2.8.1.6 Image Location Identifier

Definition: Identifies the location source for the image

Implementation Guidance:

- Mandatory
- Valid options are -
 - URL Image Location including the URL prefix (examples: http:// https://)
 - FTP Pull Location including the FTP prefix (examples: ftp:// sftp:// ftps://)
 - Directory Path on the local media

2.8.1.7 Image File Name

Definition: Unique image file name

Implementation Guidance:

- Mandatory
- Use the GDTI file naming convention ([Section 2.9](#))

2.8.2 Optional Image Attributes

2.8.2.1 Supplier Name

Definition: Name of the supplier

Implementation Guidance:

- Optional
- Alphanumeric field
- Maximum of 30 characters

2.8.2.2 Image Compressed File Size

Definition: The number of bytes of compressed file size

Implementation Guidance:

- Optional
- Provide the byte value

2.8.2.3 Image Resolution

Definition: Image pixels per inch (ppi)

Implementation Guidance:

- Optional
- Values are 300 ppi

2.8.2.4 Image Angle of Rotation and Plunge

Definition: Describes the image view of the product. Plunge is the downward angle measurement; angle is a rotational value.

Implementation Guidance:

- Optional
- Values are:
 - 1 - Center - No Plunge Angle
 - 2 - Left – No Plunge Angle
 - 3 - Right – No Plunge Angle
 - 7 - Center – Plunge Angle Present
 - 8 - Left – Plunge Angle Present
 - 9 - Right – Plunge Angle Present

Figure 2-9 Example of using Image Angle of Rotation and Plunge – Footwear



Here are some samples of footwear images and associated meta-data.

This illustrates how to use the following attributes together.

- Image Facing (required)
- Image Angle of Rotation and Plunge (optional - can be used to identify multiple angles and/or plunge of the same image facing, ie. VIK back shown with an angle of rotation and without.)



2.8.2.5 Horizontal Pixels

Definition: Horizontal pixel count of the image

Implementation Guidance:

- Optional
- Provide the numeric horizontal pixel count of the image.
- Values are:
 - Minimum 2400
 - Maximum 4800

2.8.2.6 Vertical Pixels

Definition: Vertical pixel count of the image

Implementation Guidance:

- Optional
- Provide the numeric vertical pixel count of the image.
- Values are:
 - Minimum 2400
 - Maximum 4800

2.8.2.7 Image Description

Definition: Free-form text describing the image

Example: Vertical front view of cargo pants.

Implementation Guidance:

- Optional
- Alphanumeric field
- Maximum of 1000 characters

2.8.2.8 Image Type

Definition: Indicator that the image is either an actual product image or a color swatch

Implementation Guidance:

- Optional
- Values are:
 - PRO – Product
 - CSW – Color Swatch

2.8.2.9 Image Clipping Path

Definition: A form of masking or stenciling where you can draw an outline around your image where you want it to be visible, the remaining areas become transparent

Implementation Guidance:

- Optional
- Values - Path 1

2.9 Image Naming Examples

The following image naming examples are based on the utilization of the GDTI naming format. These examples show a serialized non-intelligent format as well as a format with a built-in intelligence. Adherents to this standard are not bound to follow these examples for image naming but must follow the principles of the GDTI construction (including uniqueness of name) to assure compatibility within the sector and their trade partners.

2.9.1 Example 1: GDTI - Non-Intelligent Naming Convention

This is an example of how you could use the GDTI standard – using your GS1 Company Prefix, document type, check digit, and the optional serialized component.





GS1 Company Prefix **0657718000091CAMMY-NAT3-PRI.jpg**

The GS1 Company Prefix is attributed to the supplier by the GS1 MO (Member Organization).

Document Type **0657718000091CAMMY-NAT3-PRI.jpg**

The document type is selected by the prefix owner and is used to specify a purpose or function.

Check Digit **0657718000091CAMMY-NAT3-PRI.jpg**

This is a calculated digit, using the preceding 12 digits. Its creation is similar to that of a check digit for a GTIN.

Serialized Component (optional) **0657718000091CAMMY-NAT3-PRI.jpg**

Note: Up to 17 alpha-numeric allowed for unique identification. Could be used to identify style, or color. Could also be used to indicate facings. Facings are listed in Section 2.8.1.3 in Table 2.2-2.

2.9.2 Example 2: GDTI – Vendor-Defined Intelligent Naming Convention

This is an example of how you could use the GDTI standard using your GS1 Company Prefix, a Document Type to indicate facing and angle, Check Digit, and the optional serial component (1 to 17 alpha numeric characters) to identify the product style number for a more intelligent naming convention for internal use. See the figure below for example.

Figure 2-10 GDTI – Vendor Defined Intelligent Naming Convention



GS1 Company Prefix

0657718000121CAMMY-NAT3.jpg

The GS1 Company Prefix is attributed to the supplier by the GS1 MO (Member Organization).

Document Type

0657718000121CAMMY-NAT3.jpg

The document type is selected by the prefix owner and is used to specify a purpose or function. This could be used for the facing identifier, angle identifier, or filler digits.

GS1 Image Naming Indicator

0657718000121CAMMY-NAT3.jpg

A facing indicator example is shown below for the manual identification of the image. These facings could correlate to the facings in Section 2.8.1.3 and can be used in file naming if you wish to indicate facing in the GDTI format.

- 1 Front
- 2 Left
- 3 Top
- 7 Back
- 8 Right
- 9 Bottom

Figure 2-11 GS1 Facing Indicators - Footwear



Angle Identifier

0657718000121CAMMY-NAT3.jpg

■ An angle identifier example is shown below for the manual identification of the image face being represented.

- 1 Center; no plunge angle
- 2 Left; no plunge angle
- 3 Right; no plunge angle
- 7 Center; plunge angle present
- 8 Left; plunge angle present
- 9 Right; plunge angle present

Figure 2-12 Angle Identifiers

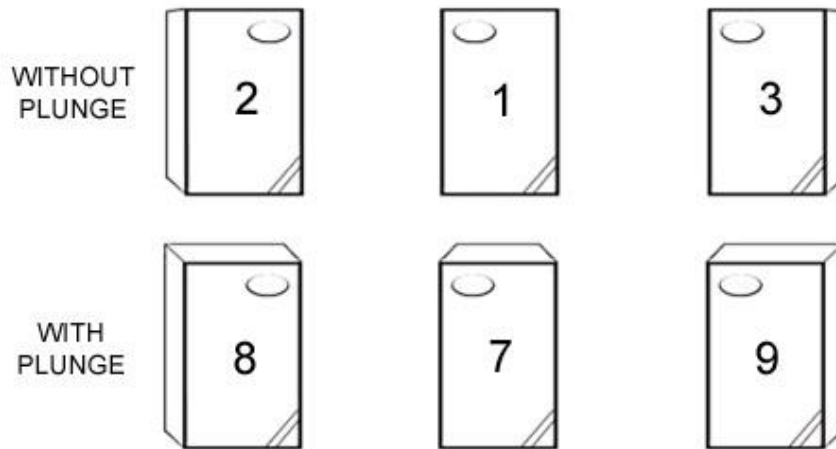

Check Digit

0657718000121CAMMY-NAT3.jpg

This is a calculated digit, using the preceding 12 digits. Its creation is similar to that of a check digit for a GTIN12/13.

Serialized Component (optional)

0657718000121CAMMY-NAT3.jpg

Note: Up to 17 alpha-numeric characters allowed for unique identification. Could be used to identify style or color. Could also be used to indicate facings. Facings are listed in Section 2.8.1.3 in Table 2.2-2.

This functionality is freeform, an example of the internal naming structure is shown for identification based on a supplier naming practice.

2.10 Supporting Documentation

The following documents were developed to assist you in implementing product image data exchange. These documents are available *separately* from this guideline.

2.10.1 Pilot Program

The following documents were developed to assist in piloting by trading partners of the Image Guidelines.

- Images Template
 - This is a spreadsheet template entitled [GS1 US Apparel and General Merchandise Attribute Template](#) and may be used to share the attribute data that is conveyed between trading partners. The spreadsheet lists image-related data and provides an example of its usage.

2.10.2 EDI 832 Price/Sales Catalog Transaction Set

The following documents were developed to provide guidance for implementing the Image Data Guidelines in the EDI 832 Price/Sales Catalog transaction set. This is applicable in Version 4020 VICS and higher.

- Images Committee: Image Attributes and 832 Mapping
 - This document is comprised of 3 sections:
 - A high-level overview of imaging and its enablement within the 832 Price/Sales Catalog transaction set.
 - A detailed review of the data elements that are used and their placement within the 832 EDI Price/Sales Catalog transaction set.
 - A set of business scenarios illustrating the use of mandatory data only or mandatory and optional data elements for image conveyance.



Table 2-3 Image Data EDI Specifics

Image Attribute	M/O	Data Type/Length	Example	VICS 832 Mapping	Mapping Explanation
Action	M	AN, 1-7	add replace delete	<u>Header Area BCT segment - field BCT10</u> BCT*RC*1234567890123*100* *****Selection Code 200 Desc*02~	BCT10 = 02 (add) BCT10 = 05 (replace) BCT10 = 03 (delete)
Vendor ID	M	AN, 1-15	Proprietary or GLN Examples: - 9-digit DUNS - 10-digit COMM ID - 12 concatenated with 10-digit phone number - 13-digit GLN - Other upon TP agreement	<u>Header Area BCT segment - field BCT02</u> BCT*RC*1234567890123*100* *****Selection Code 200 Desc*02~	RC = resale catalog 1234567890123 = Vendor ID = 13-digit GLN 100 = selection code 100 Selection Code Desc = selection code description 02 = Action code ADD
Vendor Name	O	AN, 1-30	The Best Jean Company, Inc.	<u>Header Area N1 Loop</u> N1*MF*manufacturername~	MF = manufacturer/vendor manufacturername = free-form text name of manufacturer/vendor
Image Product Identifier <i>One of the following combinations is required:</i> - Product/Style - Product/Style + Color - Product/Style + Color + Size - UPC/EAN	M	Product/Style: AN 1/20 GS1 US Color Code: N 3/3 Color Description: AN 1/20 GS1 US Size Code: N 5/5 Size Description: AN 1/10	The Identifier to which the image(s) apply. One of these is required in the LIN Segment: - Product ID/Style - Product ID/Style + (GS1 US Color Code and/or Color Desc) - Product ID/Style + (GS1 US Color Code and/or Color Desc) + (GS1 US Size Code and/or Size Desc) - UPC/EAN (the GTIN)	Product ID/Style: LIN qualifier VN Product ID/Style + Color: - LIN qualifiers VN and CM PID*F*73***colordesc~ Product ID/Style + Color + Size: - LIN qualifiers VN, CM, and SM - PID*F*73***colordesc~ - PID*F*74***sizedesc~ UPC/EAN: LIN qualifier UP or EN	This is the actual Product ID, Product ID + Color, Product ID + Color + Size, or UPC/EAN to which the image applies. Notes 1. Style, UPC, Color and Size, and their related descriptions) are mandatory when a UPC is first added, whether or not image-related attributes are also transmitted at that time. 2. Either UPC or Style or Style+Color is required when the UPC or Style already exists and a modify is being sent to store image-related attributes. 3. Style, Color, and Size Descriptions are mandatory when adding a UPC. They are optional when a UPC or Style already exists and a modify is being sent to store image-related attributes.

Image Attribute	M/O	Data Type/Length	Example	VICS 832 Mapping	Mapping Explanation
Image Application-Level Indicator	M	ID, 3/3	<p><u>An indicator of the level at which the image(s) apply.</u> One of these is required in the LM-LQ-REF segment:</p> <ul style="list-style-type: none"> - PID = Product ID/Style - CLR = Product ID/Style + GS1 US Color Code - UPC = UPC/GTIN 	<p>LM-LQ Loop - REF segment: LM*VI~ LQ**SIINTVIKJPG~ REF*PG*xxx~</p> <p>Where "xxx" is one of these valid values:</p> <ul style="list-style-type: none"> • PID = Image applies to all UPCs under the specified Product ID/Style. • CLR = Image applies to UPCs under the specified Product ID/Style having the specified color. • UPC = Image applies to the specified UPC/GTIN. 	<p>This is an indicator of the level at which the image applies: PID = Product ID/Style and all associated UPCs. CLR = All UPCs matching the Product ID/Style + GS1 US Color Code. UPC = A specific UPC. PG = the value in REF02 will be the level to which the image is applicable</p>
Image Location Type Image Location Identifier	M M	AN, 3/3 AN, 1/264	<p>One of: URL, FTP, or LMI:</p> <p>URL: http://www.imagelocation.com</p> <p>FTP: http://ftppulllocation.myco.com</p> <p>LMI: C:/MyDocuments/Pictures</p>	<p>LM-LQ Loops: each ID Type requires a separate LQ Loop</p> <p><u>1. URL</u> LM*VI~ LQ**SIINTVF1JPG~ REF*URL*X~ EFI*00*http://uniformresourcelocator.com***** 0657718000121CAMMY-LSNAT.jpg~</p> <p><u>2. FTP Pull Locator</u> LM*VI~ LQ**SIINTVF1JPG~ REF*FTP*X~ EFI*00*http://ftpsitegoeshere.com***** 0657718000121CAMMY-LSNAT.jpg~</p> <p><u>3. LMI Local Media Identifier (ex: CD)</u> LM*VI~ LQ**SIINTVF1JPG~ REF*LMI*X~ EFI*00*My Documents/Images/***** 0657718000121CAMMY-LSNAT.jpg~</p>	<p>Image Location Type: URL, FTP, or LMI. Image Location Identifier: URL location, FTP pull location, local media identifier (CD).</p> <p>SI=still image, INT=Internet, ADV= advertising or marketing related VF1=vertical front facing, JPG = file type URL = Field EFI02 will contain the image URL. X = filler for syntax purposes 00 = company non-classified information http://uniformresourcelocator.com = URL of image</p> <p>0657718000121CAMMY-LSNAT.jpg = name of file containing the image</p> <p>FTP = Field EFI02 will contain the FTP pull location.</p> <p>LMI = Field EI02 will contain the local media identifier (ex: CD directory path).</p>

Image Attribute	M/O	Data Type/Length	Example	VICS 832 Mapping	Mapping Explanation
Image File Name	M	AN, 1/64	File name (standard naming convention - GDTI) Example: 0657718000121CAMMY-LSNAT.jpg	Refer to sample EFI segments shown in Image Location Identifier 832 mappings above, in the EFI segment field EFI11 .	Notes: 1. Image File Name in the EFI segment field EFI11 is required for REF01 values URL, FTP, and LMI. 2. Image File Name for REF01 = ACL is not specified, since the EFI segment is not used in this case.
Multi Media Object Type Image Form Function Image Facing Image File Type (e.g. - storage format)	M M M M	ID, 2/2 ID, 3/3 ID, 3/3 ID, 3/3	Multi Media Object Type: Still image Image Form Function: Internet image Image Facing: Front / Back / Side / Left Side / Right Side / Top / Bottom Image File Type: .jpg	<u>LQ Segment – Field LQ02 Breakdown</u> <i>All 4 parts are mandatory.</i> <u>Part #1:</u> Char 1-2: Multi Media Object Type Value: SI = still image <u>Part #2:</u> Char 3-5: Image Form Function Value: INT = Internet <u>Part #3:</u> Char 6-8: Image Facing Values: VF1 – Front VIK – Back VIS – Side SDL – Side Left SDR – Side Right VIB – Bottom VIT – Top <u>Part #4:</u> Char 9-11: Image File type Value: JPG = .jpg	
Short Marketing Message	O	AN, 1/4096	Summary level: Free-form text that provides the "why buy" information, e.g. features & functions.	<u>LM-LQ Loop:</u> PID*S**VI*SK~ MTX**shortmarketingmessage* ***EN~	S = description type is provided in PID04 SK = short marketing message shortmarketingmessage = the short marketing message EN = English (optional language code)

Image Attribute	M/O	Data Type/Length	Example	VICS 832 Mapping	Mapping Explanation
Extended Marketing Message	O	AN, 1/8192	Detailed level: Free-form text that provide the "why buy" information, e.g. features & functions.	<u>LM-LQ Loop</u> PID*S**VI*LM~ MTX**longmarketingmessage*longmessagecontinued***EN~	S = PID04 contains the value LM = long marketing message longmarketingmessage = 1st 4096 characters of msg messagecontinued = 2nd 4096 characters of message EN = English – optional language code
Merchandise Classification	O	AN, 1/80	Swimwear	LM-LQ Loop: PID*X**VI*MC*classificationcodeortext~	X = PID04 and PID05 contain the values VI = hard-coded for 'VICS' MC = merchandise classification is in PID05 classificationcodeortext = merchandise classification
Image Description	O	AN, 1/1000	Freeform description <= 1000 characters. For example: - "Single shoe" - "Multiple shoes" - "Shoes of all colors in 1 image" Note: Whether the image shows the product in or out of its packaging should be included here, if desired.	<u>LM-LQ-PID Loop</u> LM*VI~ LQ**SIINTSDRJP~ PID*S**VI*IM~ MTX**imagedescription**NS**EN~	
Image Type	O	ID, 3/3	Indicator of what is captured in the image. For example, the image is of an actual product, or it might be a color swatch.	<u>LM-LQ-PID Loop</u> PID*X**VI*TP*ccc~ Where 'ccc' is one of the following values: • CSW – Color Swatch • PRO - Product	X = PID04 and PID05 will be populated. VI = hard-coded for 'VICS' TP = image type indicator ccc = 3-character value from valid codes list.

Image Attribute	M/O	Data Type/Length	Example	VICS 832 Mapping	Mapping Explanation
Angle of Rotation and Plunge	O	N, 1/1	Straight / Left / Right	<u>LM-LQ-PID Loop</u> PID*X**VI*PL*n~ Where 'n' is one of these valid values: 1 - Center; no plunge angle 2 - Left; no plunge angle 3 - Right; no plunge angle 7 - Center; plunge angle present 8 - Left; plunge angle present 9 - Right; plunge angle present	X = PID04 and PID05 are populated VI = hard-coded value for 'VICS' PL = Angle of Plunge/Rotation n = 1-digit numeric value representing the combination of plunge + rotation.
Image Resolution	O	N, 1/6	72 ppi	<u>LM-LQ-PID Loop</u> PID*S**VI*DP~ MEA**D9*300*EA~	DP = dots per inch (equivalent to pixels per inch) D9 = dpi (equivalent to ppi) 300 = # of dots/pixels per inch EA = each
Compressed File Size	O	N, 1/20	128000 bytes	<u>LM-LQ-PID Loop</u> PID*S**VI*CF~ MEA**DO*128000*AD~	CF = compressed file size DO = compressed file size 128000 = # of bytes in compressed file size AD = bytes
Pixel Height (vertical) Pixel Width (horizontal)	O O	N, 1/6 N, 1/6	2400 x 2400 pixels	<u>LM-LQ-PID Loop</u> PID*S**VI*PC~ MEA**D6*2400*EA~ MEA**D8*2400*EA~	PC = pixel count D6 = horizontal D8 = vertical
Clipping Path	O	AN, 1/80	"Path 1"	<u>LM-LQ-PID Loop</u> PID*X**VI*CL*Path 1~	X = PID04 and PID05 will be populated. VI = hard-coded for 'VICS' CL = clipping path Path 1 = clipping path value specified in imaging guidelines.

2.10.3 Other Supporting Documentation

These documents denote proposed changes to the VICS EDI guidelines in support of the Imaging Guideline.

- VICS 832 Change Requests
 - This document denotes changes to the VICS 832 Price/Sales Catalog guideline.
 - Visit the GS1 US EDI library for this transaction set document.
- VICS EDI Guideline, Section III, Data Element 1271
 - This document denotes changes to data element 1271 Multi-Media Object Codes.

- Visit the GS1 US EDI library for this transaction set document.

2.11 Frequently Asked Questions

1. How do these guidelines relate to the current GS1 image specifications?

These guidelines are an expansion to the existing [GS1 Product Image Specification](#) referencing the technical requirements and base rules governing the size, shape, and graphic components while adding an additional application level for images intended for eCommerce/internet use.

2. Are these guidelines compatible with GDSN?

This guideline has been submitted for inclusion within the Global Data Synchronization Network.

3. How is a white image with white background defined?

All images, regardless of color, must have a close-cropped path defined. This path is a graphic tool which allows for the application of a varied background to better showcase the item imaged.

4. Are thumbnail images defined in the guideline?

Thumbnail images were deemed out-of-scope for this initiative. It was reasoned that a larger image could be reduced to a thumbnail if one was required by the end user based on their particular requirements.

5. What is the difference between JPG and JPEG?

Technically, there is no difference between JPG and JPEG. In a system sense, certain operating systems are incapable of accepting a 4-character suffix, and thus the two forms co-exist. (JPG / JPEG = Joint Photographic Expert Group)

6. What is the Pantone Matching System (PMS)?

The [Pantone Matching System Chart](#) is a set of standard colors for printing, each of which is specified by a single number.

7. What characters are invalid in an image name?

System requirements have file name restrictions with regard to special characters being used in the file name. (See Question 8 below for EDI character restrictions in image file naming.) Following is a list of invalid characters and should not be used in the image file name:

Table 2-4 Invalid Characters for an Image File Name

Character	Name	Reason
/	Slash	Used as a path name component separator in Unix-like, Windows, and Amiga systems. (The MS-DOS command.com shell would consume it as a switch character, but Windows itself always accepts it as a separator.[4][vague])
\	backslash	Also used as a path name component separator in MS-DOS, OS/2 and Windows (where there are few differences between slash and backslash); allowed in Unix filenames, see Note 1.
?	question mark	Used as a wildcard in Unix, Windows and AmigaOS; marks a single character. Allowed in Unix filenames, see Note 1.
%	Percent	Used as a wildcard in RT-11; marks a single character.

Character	Name	Reason
*	asterisk or star	Used as a wildcard in Unix, MS-DOS, RT-11, VMS and Windows. Marks any sequence of characters (Unix, Windows, later versions of MS-DOS) or any sequence of characters in either the basename or extension (thus "*.*" in early versions of MS-DOS means "all files". Allowed in Unix filenames, see note 1
:	Colon	Used to determine the mount point / drive on Windows; used to determine the virtual device or physical device such as a drive on AmigaOS, RT-11 and VMS; used as a pathname separator in classic Mac OS. Doubled after a name on VMS, indicates the DECnet nodename (equivalent to a NetBIOS (Windows networking) hostname preceded by "\\").
	vertical bar or pipe	Designates software pipelining in Unix and Windows; allowed in Unix filenames.
"	Quote	Used to mark beginning and end of filenames containing spaces in Windows, see Note 1.
<	less than	Used to redirect input, allowed in Unix filenames, see Note 1.
<	less than	Used to redirect input, allowed in Unix filenames, see Note 1.
>	greater than	Used to redirect output, allowed in Unix filenames, see Note 1.
.	period or dot	Allowed, but the last occurrence will be interpreted to be the extension separator in VMS, MS-DOS and Windows. In other Operating Systems, usually considered as part of the filename, and more than one period (full stop) may be allowed.

8. What characters are restricted in EDI?

Since the image file name will be carried within an EDI file, special care must be taken to assure that the filename does not conflict with (1) X12 character set standards, (2) X12 delimiter standards, and (3) transmission protocol standards.

It is recommended to only use alpha numeric characters in the image file name.

Data carried within an X12 EDI file may only contain characters approved for use by the X12 Standards. X12 character sets include the 'Basic' Character Set and the 'Extended' Character Set, which includes uppercase and lowercase letters, digits, special characters, national characters, and select language characters. Refer to the X12.6 Application Control Structure Standard for information on the Character Sets.

X12.5 Interchange Control Structures Standard - Appendix A covers implementation considerations regarding character sets used in the interchange of the transaction sets with particular emphasis on the delimiters. Delimiters within the X12 Standard include the Segment Terminator, Data Element Separator, Sub-Element Separator, and Repetition Separator.

Common delimiter characters include the asterisk (*), backslash (\), tilde (~) and carat (^). Due to the function of a delimiter character, it must not appear anywhere within the 'value' string of a data element as in the Image File Name.

Additionally, because of the potential conflicts with either the data elements or with special uses in transmission and device control, the selection of delimiter characters must be done with caution. X12 has a set of recommended delimiter values in X12.5.

9. How do you name an oblique image? (This is the most common image used.) Is it possible to use the 45-degree angle shot (to see multiple face of image) as the standard shot?

There is a standard or 'primary' shot used in most depictions of a product type (e.g., shoes; jewelry; clothing). A new data identifier has been created to identify this image. In terms of the naming structure, it need only be uniquely named and properly linked to the corresponding data.

10. Are there optional product classifications?

Determining product classification guidelines are outside of this committee’s scope.

11. Do we standardize using the “right” shoe, glove, etc.?

When showing six sides of a shoe or glove, the right one is considered the default, as per the industry

12. How are Copyright, Image Time Limit, and Model Usage Fees addressed in the guideline?

These items are not addressed in the guideline and should be addressed between trading partners.

2.12 Value Proposition

Understanding the Benefits of Implementing this Guideline

This Guideline was developed by suppliers and retailers to simplify and reduce the cost and effort of current business practices. Both vendors and retailers stand to benefit from the adoption of a common e-commerce image and file naming specification. These benefits are captured in the table below.

Table 2-5 Process Improvement – Vendor View

Case 1. Where the vendor is fully responsible for image production and distribution, a common image specification helps reduce the effort and cost necessary to maintain multiple (proprietary) customer requirements.	Case 2. Where the retailer has been responsible for generating product images, the vendor has an opportunity to cost-effectively assume this function.
<p>The savings are proportional to the number of retailers adopting the specification.</p> <p>Tangible savings:</p> <ul style="list-style-type: none"> ▪ Minimize incremental image production costs ▪ Facilities ▪ Labor (image capture, adjustment/generation, validation) ▪ Storage <p>Intangible savings:</p> <ul style="list-style-type: none"> ▪ Reduced delays resulting from the need for custom photography. Faster introduction of new products ▪ Increased image quality/consistency across customer base ▪ Reduced staff time and effort managing individual retailer requirements <p>Standard filename convention improves identification of image to supplier and to individual images (reduces risk of posting the wrong image)</p>	<p>The savings are proportional to the number of retailers who discontinue the practice of producing their own images.</p> <p>Intangible savings:</p> <ul style="list-style-type: none"> ▪ Eliminates the need to manage distribution of product samples across multiple retailers ▪ Reduced delays resulting from the need for samples and custom photography ▪ Faster introduction of new products ▪ Increased image quality/consistency across customer base

Table 2-6 Process Improvement – Retailer View

Case 1. Where the vendor is responsible for image production and distribution, a common specification helps improve the acquisition of product images across the entire supplier base.	Case 2. Where the retailer is responsible for image production, a common specification provides the opportunity for a greater number of vendors to assume this function.
<p>The savings are proportional to the number of vendors who successfully adopt the best practice specification.</p> <p>Tangible savings</p> <ul style="list-style-type: none"> ▪ Fewer errors and quality issues requiring the retailer to re-shoot the image. ▪ Minimize retailer’s image production costs. ▪ Facilities ▪ Labor (image capture, adjustment/generation, validation) <p>Intangible savings</p> <ul style="list-style-type: none"> ▪ Reduced delays resulting from the need for custom photography. ▪ Faster introduction of new products ▪ Improved consistency of image quality across vendor base <p>Standard filename convention improves identification of image to vendor and to individual images (reduces risk of posting the wrong image)</p>	<p>The savings are proportional to the number of vendors who can successfully provide images to the best practice specification.</p> <p>Tangible savings</p> <ul style="list-style-type: none"> ▪ Minimize image production costs ▪ Facilities ▪ Labor (image capture, adjustment/generation, validation) <p>Intangible savings</p> <ul style="list-style-type: none"> ▪ Reduced delays resulting from the need for samples from vendors or from stock. ▪ Reduced delays resulting from the retailer to create necessary photography. ▪ Faster introduction of new products.

3 General Attribute Guidance

3.1 How Do I Use the Attribute Sections of this Guideline?

- *Section 3.2* provides a matrix showing the attributes that are possibly appropriate for your type of merchandise. It is important to refer to *Section 3.4* and *3.5* for complete definitions.
- Read *Section 3.4*, which reviews the e-commerce Extended Consumer Product Attributes that are generally applicable to all merchandise categories covered in this guideline.
- Read *Section 3.5*, which reviews the E-Commerce Extended Consumer Product Attributes for all remaining attribute definitions, examples, and data types. *Section 3.6* provides the code lists for the extended attributes.
- *Sections 3.8*, *Section 3.9*, and *Section 3.10* provide additional guidance, including examples of using attributes in a webpage, mapping of the attributes in Electronic Data Interchange (EDI), and a spreadsheet for exchanging information.

After you have read and shared this guideline with your trading partner(s), discuss possible enhancements to your existing data feeds. Does the new attribute exist but is not being passed, or does it need to be “created”? All parties will need sufficient time to retrofit existing information transfers (through spreadsheet, EDI, etc.).

The use of a specific attribute will depend on product or product class, the needs of your company and your trading partner, and relevance to the consumer in making an online purchase.

In order to make attribute selection easier, the Products Images and Data Attributes workgroup, made up of brands and retailers, have deemed specific attributes as “essential.” An essential attribute is defined as an attribute that is commonly required for item set-up and eCommerce. Attributes were reviewed by product category at the Global Product Classification (GPC)/Brick level to determine if that attribute is essential for that product. **For a complete matrix of essential attributes by GPC click [here](#). For a more detailed description of GPC click [here](#).**

3.2 Product Attribute Overview Matrix by Product Category

Core	Apparel	Footwear	Jewelry	Fashion Accessories	Beauty	Home
Product	X	X	X	X	X	X
Product Description	X	X	X	X	X	X
Global Trade Item Number® (GTIN®)	X	X	X	X	X	X
Color Description	X	X	X	X	X	X
GS1 US Color Code	X	X	X	X	X	X
Size Description	X	X	X	X	X	X
GS1 US Size Code	X	X	X	X	X	X

E-Commerce and Supply Chain	Apparel	Footwear	Jewelry	Fashion Accessories	Beauty	Home
Adhesive	X					
Adjustable	X		X	X		
Adjustable Strap	X	X	X	X	X	X
Advertised Origin	X	X	X	X	X	X
Aerosol Product					X	X
Asthma/Allergy Certified						X
Bag Type				X		X
Band Type			X			
Beauty Area of Use					X	
Beauty Treatment Specialty					X	
Beauty Type					X	
Bedding Size						X
Bedding Type						X
Belt Type				X		
Benzoyl Peroxide Resistant						X
Bill Logo Application				X		
Bill Type				X		
Boot Leg Circumference		X				
Boot Shaft Height		X				
Boot Shaft Type		X				
Boxed for Gift Giving	X	X	X	X	X	X
Bra Band Type	X					



E-Commerce and Supply Chain	Apparel	Footwear	Jewelry	Fashion Accessories	Beauty	Home
<u>Bra Bust Type</u>	X					
<u>Bra Cup Coverage</u>	X					
<u>Bra Cup Type</u>	X					
<u>Bra Impact Level</u>	X					
<u>Bra Padding</u>	X					
<u>Bra Specialty Type</u>	X					
<u>Bra Type</u>	X					
<u>Bra Underwire</u>	X					
<u>Bracelet Type</u>			X			
<u>Brand Name</u>	X	X	X	X	X	X
<u>Care Information</u>	X	X		X		X
<u>Care Instructions Code</u>	X	X		X		X
<u>Circularity Certifications</u>	X	X	X	X	X	X
<u>Closure</u>	X	X	X	X		X
<u>Coat/Jacket Type</u>	X					
<u>Collar Type</u>	X					
<u>Color Extended Description</u>	X	X	X	X	X	X
<u>Conference</u>	X	X	X	X		X
<u>Consumer Available Date</u>	X	X	X	X	X	X
<u>Consumer Item Depth</u>				X		X
<u>Consumer Item Height</u>				X		X
<u>Consumer Item Length</u>	X		X	X		X
<u>Consumer Item Weight</u>	X	X	X	X	X	X
<u>Consumer Item Width</u>	X		X	X		X
<u>Consumer Life Stage</u>	X	X	X	X	X	X
<u>Consumer Package Depth</u>	X	X	X	X	X	X
<u>Consumer Package Gross Weight</u>	X	X	X	X	X	X
<u>Consumer Package Height</u>	X	X	X	X	X	X
<u>Consumer Package Width</u>	X	X	X	X	X	X
<u>Consumer Product Capacity or Volume</u>					X	X
<u>Consumer Quantity of Units in Consumer Package</u>	X	X	X	X	X	X
<u>Control Level</u>	X					
<u>Convertible</u>	X	X		X		
<u>Cookware Type</u>						X
<u>Country of Origin</u>	X	X	X	X	X	X



E-Commerce and Supply Chain	Apparel	Footwear	Jewelry	Fashion Accessories	Beauty	Home
Covered						X
CPSIA Flag	X	X	X	X	X	X
Crown				X		
Cuff Type	X					
Detachable Strap	X			X		X
Dinnerware Category						X
Discontinue Date	X	X	X	X	X	X
Dishwasher Safe						X
Does Not Contain					X	
Dress Type	X					
Earring Drop			X			
Earring Type			X			
Eyewear Type				X		
Fabric or Material Code	X	X	X	X		X
Fabric or Material Description	X	X	X	X		X
Faux Fur	X	X	X	X		X
Features – Benefits – Marketing Message	X	X	X	X	X	X
Fiber	X	X	X	X		X
Fill Material						X
Finish	X	X	X			X
First Avail Ship Date	X	X	X	X	X	X
First Order Date	X	X	X	X	X	X
Fit				X		
Flatware Type						X
Formulation					X	
Full Product Name	X	X	X	X	X	X
Fur Animal Name	X	X	X	X		X
Fur Country of Origin	X	X	X	X		X
Fur Treatment	X	X	X	X		X
Gauge	X			X		X
Gender	X	X	X	X	X	X
Global Product Classification (GPC)	X	X	X	X	X	X
Glove Type				X		
Gold Karat			X			
Hand Painted						X



E-Commerce and Supply Chain	Apparel	Footwear	Jewelry	Fashion Accessories	Beauty	Home
Handbag Shoulder Drop				X		
Handle Strap				X		
Handmade						X
Harmonized Tariff Schedule Code	X	X	X	X	X	X
Hat Type				X		
Hazardous Material Class Code					X	X
Hazardous Material Description					X	X
Heel Height		X				
Heel Height Range		X				
Heel Material		X				
Heel Type		X				
Holiday/Event	X	X	X	X	X	X
Hooded	X					
Hosiery/Sock Type				X		
Hypoallergenic					X	X
Ingredients					X	
Inner Pack Quantity	X	X	X	X	X	X
Insulated		X				X
Jewelry Sets			X			
Jewelry Type			X			
Key Active Ingredient					X	
Knit Type	X			X		
Laser Cut	X	X	X	X		X
Lead Time	X	X	X	X	X	X
League	X	X	X	X		X
Leather Animal Name	X	X		X		X
Leg Type	X					
Length Description	X					
Lined	X	X		X		X
Lining Material	X	X		X		X
Marked Retail Price	X	X	X	X	X	X
Material Country of Origin	X	X	X	X	X	X
Maternity	X					
Metal			X			
Metal Composition						X



E-Commerce and Supply Chain	Apparel	Footwear	Jewelry	Fashion Accessories	Beauty	Home
Metal Feet				X		
Microwave Safe						X
Min Order Quantity	X	X	X	X	X	X
Necklace Type			X			
Neckwear Type				X		
Number of Settings						X
Occasion	X	X	X	X	X	X
Officially Licensed	X	X	X	X		X
Oil Free					X	
Open/Closed Toe		X				
Order Quantity Multiple	X	X	X	X	X	X
Outsole Type		X				
Padded				X		
Pant Inseam Length	X					
Pants/Shorts Type	X					
Panty Back Coverage	X					
Panty Type	X					
Platform Height		X				
Player Name	X			X		
Pocket Details	X			X		
Primary Detail Application	X			X		X
Primary Detail Logo	X			X		X
Primary Detail Placement	X			X		X
Primary Detail Size	X			X		X
Primary Detail Type	X			X		X
Primary Motif Theme	X			X		X
Prop 65	X	X	X	X	X	X
Refillable					X	
Re-orderable	X	X	X	X	X	X
Responsible Manufacturing	X	X	X	X	X	X
Reversible	X			X		X
Ring Type			X			
Ruq Type						X
Scarf Type				X		
Scent Type					X	X



E-Commerce and Supply Chain	Apparel	Footwear	Jewelry	Fashion Accessories	Beauty	Home
Seams				X		
Secondary Detail Application	X			X		X
Secondary Detail Logo	X			X		X
Secondary Detail Placement	X			X		X
Secondary Detail Size	X			X		X
Secondary Detail Type	X			X		X
Secondary Motif Theme	X			X		X
Selling Channel	X	X	X	X	X	X
Shape						X
Shapewear Type	X					
Shippable Package/Carton	X	X	X	X	X	X
Shoe Style		X				
Shoe Type		X				
Skin Type					X	
Skirt Type	X					
Sleepwear Type	X					
Sleeve Measurement	X					
Sleeve Type	X					
Slip Split	X					
Slip Type	X					
Sole Type		X				
Social Certifications	X	X	X	X	X	X
Special Embellishment	X	X				
Special Handling Code			X		X	X
Special Item Code	X	X	X	X	X	X
SPF Rating	X				X	
Sport	X	X		X		X
Stay Cool Handle						X
Steamable	X			X		X
Stone Details			X			
Strap Placement	X	X		X		X
Stretch	X	X	X	X		
Supplemental Circularity Certifications	o	X	X	X	X	X
Supplemental Corporate/Philanthropic	X	X	X	X	X	X
Supplemental Packaging Certifications	X	X	X	X	X	X



E-Commerce and Supply Chain	Apparel	Footwear	Jewelry	Fashion Accessories	Beauty	Home
Supplemental Raw Materials Certifications	X	X	X	X	X	X
Supplemental Traceability Programs	X	X	X	X	X	X
Supplier Suggested Retail	X	X	X	X	X	X
Supplier Wholesale Price	X	X	X	X	X	X
Supply Type	X	X	X	X	X	X
Support Level	X					
Sustainable Materials	X	X	X	X	X	X
Sustainable Packaging	X	X	X	X	X	X
Sweater/Pullover Type	X					
Swim Bottom Type	X					
Swim Coverup Type	X					
Swim One-Piece Type	X					
Swim Top Type	X					
Tableware Type						X
Tag	X			X		
Team Name	X	X	X	X		X
Third Detail Application	X			X		X
Third Detail Logo	X			X		X
Third Detail Placement	X			X		X
Third Detail Size	X			X		X
Third Detail Type	X			X		X
Third Motif Theme	X			X		X
Toe Shape		X				
Toe Style		X				
Towel Type						X
Vendor Collection Name	X	X	X	X	X	X
Waist Rise	X					
Waistband Type	X					
Warranty Description			X			X
Watch Band Width			X			
Watch Case Shape			X			
Watch Case Size			X			
Water Repellent	X	X		X	X	X
Wrinkle Resistant	X	X		X	X	X



E-Commerce and Supply Chain		Apparel	Footwear	Jewelry	Fashion Accessories	Beauty	Home
TOTALS	211	129	80	74	108	59	118

3.3 Product Measurements

The accurate and consistent dimensional measurement of trade items and trade item packaging is the key to a successful implementation of data alignment/synchronization between trading partners. The information is also important to the consumer. In order to promote accuracy, GS1 and its member communities (including apparel) developed the [GS1 Package Measurement Rules](#) to provide guidance for (1) accurately measuring products and (2) accurately communicating those measurements between trading partners.

For a packaged consumer trade item, the [GS1 Package Measurement Rules](#) use the following measurement types:

- width (from left to right)
- height (from base to the top)
- depth (from front to back)

Note: Length is not used in the standard.

GS1 provides two key documents to guide you in accurately measuring trade items: [GS1 Package Measurement Rules](#) and the [GS1 Package Measurement Rules Implementation Guide](#).

3.4 Core/Common Attributes

The core product attributes are generally exchanged during the listing process and are applicable across most merchandise categories.

3.4.1 Product

General Definition	This is the vendor's primary identification of a product and, therefore, is usually the meaningful link to the GTIN. The trade item must be represented consistently across all media, including tickets, Universal Product Code (U.P.C.) Catalogs, glossy catalogs, line/price listings, etc., to assure that automated matches can be made with product information supplied to the retail buyers.
Also Known As	Item Number, Product ID, Style Number, Model Number
Business Example	A100, 2685NB94
Business and Data Integrity Rules	
Attribute Length	Maximum 20 characters
Product Category	Common

3.4.2 Product Description

General Definition	Primary product description that provides a meaningful description of the product represented by the vendor product identifier. Product descriptions are used extensively by retailers for both product selection and error resolution and should be detailed enough to aid in this process. Product descriptions should be present unless the product identifier itself is synonymous with the product description.
Also Known As	Item, Style, Model Description
Business Example	Flirt Neck Blouse, Monica Cross Body Bag
Business and Data Integrity Rules	
Attribute Length	Maximum 20 characters
Product Category	Common

3.4.3 GTIN – Global Trade Item Number

General Definition	Global Trade Item Number (GTIN) is the GS1 identification number for trade items. There are four formats associated with the GTIN: <ul style="list-style-type: none"> ▪ GTIN-8 (8 digits) ▪ GTIN-12 (12 digits) ▪ GTIN-13 (13 digits) ▪ GTIN-14 (14 digits)
Also Known As	
Business Example	614141026753
Business and Data Integrity Rules	
Attribute Length	14 digits

Product Category	Common
-------------------------	--------

3.4.4 Color Description

General Definition	Primary color description that provides a text expression of the color. Whenever possible, this should be the color displayed on product label.
Also Known As	
Business Example	<ul style="list-style-type: none"> ▪ White ▪ Black ▪ Navy
Business and Data Integrity Rules	
Attribute Length	Maximum 10 characters
Product Category	Common

3.4.5 GS1 US Color Code

General Definition	A supplier-assigned color identifier (ID) from the list of valid GS1 US color codes. The GS1 US standard color codes give retailers and suppliers a common language for color identification. For additional information, please visit the GS1 US Color and Size Code webpage .
Also Known As	
Business Example	<ul style="list-style-type: none"> ▪ 100 (for White) ▪ 001 (for Black) ▪ 440 (for Navy)
Business and Data Integrity Rules	
Attribute Length	Maximum 3 – Numeric
Product Category	Common

3.4.6 Size Description

General Definition	Primary size description providing text expression of the size. Whenever possible, this should be the size that is displayed on the product label.
Also Known As	
Business Example	<ul style="list-style-type: none"> ▪ One Size Fits All ▪ 6.5 B ▪ Towel, Beach
Business and Data Integrity Rules	
Attribute Length	Maximum 10 characters
Product Category	Common



3.4.7 GS1 US Size Code

General Definition	A supplier-assigned size ID from the list of valid GS1 US size codes. The GS1 US standard size codes give retailers and suppliers a common language for size identification. For additional information, please visit the GS1 US Color and Size Code webpage .
Also Known As	
Business Example	<ul style="list-style-type: none">▪ 30001 (One Size Fits All in Junior/Misses/Women's)▪ 50365 (6.5 B in Footwear)▪ 60694 (Towel, Beach)
Business and Data Integrity Rules	
Attribute Length	Maximum 5 – Numeric
Product Category	Common

3.5 E-Commerce Extended Consumer Product Attributes

3.5.1 Adhesive

General Definition	The ability to stick to the wearer, other portion of the product, or another separate product.
Also Known As	
Business Example	If used in Intimate Apparel for support that does not rely on straps or traditional bra structure, using medical grade adhesive to attach to the skin.
Business and Data Integrity Rules	Expressed as: <ul style="list-style-type: none"> ▪ Y (adhesive) or ▪ N (not adhesive)
Attribute Length	1 Character
Product Category	Apparel
Essential Attribute	No

3.5.2 Adjustable

General Definition	The ability to change so as to be suitable to or conform to a specific user's needs.
Also Known As	
Business Example	
Business and Data Integrity Rules	Expressed as: <ul style="list-style-type: none"> ▪ Y (adjustable) or ▪ N (not adjustable)
Attribute Length	1 Character
Product Category	Apparel, Jewelry, Fashion Accessories
Essential Attribute	Yes For Specific GPC bricks see Essential Attribute Matrix

3.5.3 Adjustable Strap

General Definition	The ability to change the strap at specific levels.
Also Known As	
Business Example	<ul style="list-style-type: none"> ▪ GM03ADSTFA (Fully Adjustable) ▪ GM03ADSTNA (Non Adjustable)
Business and Data Integrity Rules	<ul style="list-style-type: none"> ▪ For a full list of values, see the Adjustable Strap Code List
Attribute Length	80 Characters

Product Category	Common
Essential Attribute	Yes For Specific GPC bricks see Essential Attribute Matrix

3.5.4 Advertised Origin

General Definition	In the USA, labelling requirements as defined by the FTC Act and outlined in the <i>Complying with the Made in USA Standard</i> documentation. USA reference: https://www.ftc.gov/tips-advice/business-center/guidance/complying-made-usa-standard In Canada, labelling requirements as defined by the <i>Consumer Packaging & Labelling Act</i> and the <i>Textile Labelling Act</i> . Canadian reference: http://www.competitionbureau.gc.ca/eic/site/cb-bc.nsf/eng/03169.html . ¹
Also Known As	<ul style="list-style-type: none"> ▪ Made in the U.S.A. Standard ▪ Made in Canada Regulations
Business Example	<ul style="list-style-type: none"> ▪ GM03ADVOMC (Made in Canada) ▪ GM03ADVOMU (Made in U.S.A.)
Business and Data Integrity Rules	For a full list of values, see the Advertised Origin Code List .
Attribute Length	Maximum 80 characters
Product Category	Common (could apply to all merchandise categories)
Essential Attribute	Essential for ALL GPC bricks see Essential Attribute Matrix

3.5.5 Aerosol Product

General Definition	Indicates that the product contains a compressed gas or propellant (as opposed to use of a pump).
Also Known As	
Business Example	<ul style="list-style-type: none"> ▪ Bathroom spray ▪ Hairspray ▪ Suntan lotion
Business and Data Integrity Rules	Expressed as: <ul style="list-style-type: none"> ▪ Y (contains aerosol) or ▪ N (does not contain aerosol)
Attribute Length	1 character
Product Category	Beauty, Home
Essential Attribute	Yes For Specific GPC bricks see Essential Attribute Matrix

¹ "Complying with the Made in the USA Standard. Retrieved on March 11, 2019 from: <https://www.ftc.gov/tips-advice/business-center/guidance/complying-made-usa-standard>.

3.5.6 Asthma/Allergy Certified

General Definition	Indicator designating item has passed AAFA Certification. In order to be Allergy Certified, a product needs to pass an allergy risk assessment that the product does not contain any of the official list of harmful chemicals, such as those that are known to be allergenic.
Also Known As	
Business Example	Vacuum cleaners Bedding products
Business and Data Integrity Rules	<ul style="list-style-type: none"> ▪ Expressed as: ▪ Y (is Asthma/Allergy Certified) or ▪ N (is not Asthma/Allergy Certified)
Attribute Length	1 Character
Product Category	Home
Essential Attribute	No

3.5.7 Bag Type

General Definition	Indicator of the use or shape of a handbag or other bag, sometimes incorporating the handle description if needed.
Also Known As	
Business Example	<ul style="list-style-type: none"> ▪ GM03BGSTCR (Crossbody) ▪ GM03BGSTDB (Diaper Bag)
Business and Data Integrity Rules	For a full list of values, see the Bag Type Code List .
Attribute Length	80 Characters
Product Category	Fashion Accessories
Essential Attribute	Yes For Specific GPC bricks see Essential Attribute Matrix

3.5.8 Band Type

General Definition	Describes a flat, thin strip or loop of material put around something, typically to hold it together or to decorate it.
Also Known As	
Business Example	<ul style="list-style-type: none"> ▪ JW03WBNDU (Cuff) ▪ JW03WBNDNA (NATO Strap)
Business and Data Integrity Rules	For a full list of values, see the Band Type Code List .

Attribute Length	80 Characters
Product Category	Jewelry
Essential Attribute	Yes For Specific GPC bricks see Essential Attribute Matrix

3.5.9 Beauty Area of Use

General Definition	The external area of the body to which a specific product is to be applied.
Also Known As	
Business Example	<ul style="list-style-type: none"> ▪ GM03BAOUEY (Eye) ▪ GM03BAOUFA (Face) ▪ GM03BAOUHR (Hair)
Business and Data Integrity Rules	For a full list of values, see the Beauty Area of Use Code List .
Attribute Length	80 Characters
Product Category	Beauty
Essential attribute	Yes For Specific GPC bricks see Essential Attribute Matrix

3.5.10 Beauty Treatment Specialty

General Definition	Intended usage or condition that the product addresses.
Also Known As	
Business Example	<ul style="list-style-type: none"> ▪ GM03BTSPRE (Repair) ▪ GM03BTSPST (Self Tan)
Business and Data Integrity Rules	For a full list of values, see the Beauty Treatment Specialty Code List .
Attribute Length	80 Characters
Product Category	Beauty
Essential attribute	Yes For Specific GPC bricks see Essential Attribute Matrix

3.5.11 Beauty Type

General Definition	Products used as cosmetics, skin care, hair care or beauty accessories
Also Known As	
Business Example	<ul style="list-style-type: none"> ▪ GM03BATYAS (After shave) ▪ GM03BATYBC (Base Coat)
Business and Data Integrity Rules	For a full list of values, see the Beauty Type Code List

Attribute Length	80 Characters
Product Category	Beauty
Essential Attribute	Yes For Specific GPC bricks see Essential Attribute Matrix

3.5.12 Bedding Size

General Definition	Standard size of bedding products.
Also Known As	
Business Example	<ul style="list-style-type: none"> ▪ GM03BDSZKI (King) ▪ GM03BDSZQU (Queen)
Business and Data Integrity Rules	For a full list of values, see the Bedding Size Code List .
Attribute Length	80 Characters
Product Category	Home
Essential Attribute	No

3.5.13 Bedding Type

General Definition	Indicates the use or placement of the bedding.
Also Known As	
Business Example	<ul style="list-style-type: none"> ▪ GM03BEDTCM (Comforter) ▪ GM03BEDTDC (Duvet)
Business and Data Integrity Rules	For a full list of values, see the Bedding Type Code List .
Attribute Length	80 Characters
Product Category	Home
Essential Attribute	No

3.5.14 Belt Type

General Definition	Products used either around the waist or over the shoulders to support clothing.
Also Known As	
Business Example	<ul style="list-style-type: none"> ▪ GM03BETYBR (Braided) ▪ GM03BETYVH (Chain)
Business and Data Integrity Rules	For a full list of values, see the Belt Type Code List
Attribute Length	80 Characters
Product Category	Apparel, Accessories

Essential Attribute	Yes For Specific GPC bricks see Essential Attribute Matrix
----------------------------	---

3.5.15 Benzoyl Peroxide Resistant

General Definition	Resistant to stains and discoloration from Benzoyl Peroxide.
Also Known As	
Business Example	
Business and Data Integrity Rules	Expressed as: <ul style="list-style-type: none"> ▪ Y (is Benzoyl Peroxide Resistant) or ▪ N (is not Benzoyl Peroxide Resistant)
Attribute Length	1 Character
Product Category	Home
Essential Attribute	No

3.5.16 Bill Logo Application

General Definition	Indicates the style of application to a hat bill.
Also Known As	
Business Example	<ul style="list-style-type: none"> ▪ GM03BILLFA (Fabric Applique) ▪ GM03BILLRE (Raised Embroidery)
Business and Data Integrity Rules	For a full list of values, see the Bill Logo Application Code List .
Attribute Length	80 Characters
Product Category	Fashion Accessories
Essential Attribute	No

3.5.17 Bill Type

General Definition	The shape or form of the front part of a cap that shades the wearer's face from sunlight.
Also Known As	
Business Example	<ul style="list-style-type: none"> ▪ GM03BILTFU (Flip Up) ▪ GM03BILTNL (Normal)
Business and Data Integrity Rules	For a full list of values, see the Bill Type Code List .
Attribute Length	80 Characters
Product Category	Fashion Accessories
Essential Attribute	No

3.5.18 Boot Leg Circumference

General Definition	Measurement around the shaft of the boot at its largest part.
Also Known As	
Business Example	 <p>Circumference measured at the largest part of the boot shaft</p>
Business and Data Integrity Rules	Requires the measurement value and an accompanying unit of measure.
Attribute Length	Maximum 20 numeric (including decimal)
Product Category	Footwear
Essential Attribute	Yes For Specific GPC bricks see Essential Attribute Matrix

3.5.19 Boot Shaft Height

General Definition	The height of the shaft measured along the back of the boot, from the top of the heel to the top of the boot shaft.
Also Known As	
Business Example	
Business and Data Integrity Rules	Requires the measurement value and an accompanying unit of measure.
Attribute Length	Maximum 20 numeric (including decimal)
Product Category	Footwear
Essential Attribute	Yes For Specific GPC bricks see Essential Attribute Matrix

3.5.20 Boot Shaft Type

General Definition	Indicates the descriptive term that is used by the product manufacturer to identify the boot shaft.
Also Known As	Length of boot shaft
Business Example	<ul style="list-style-type: none"> ▪ GM03BTSTAN (Ankle) ▪ GM03BTSTKH (Knee High) add ranges
Business and Data Integrity Rules	For a full list of values, see the Boot Shaft Type Code List .
Attribute Length	80 Characters
Product Category	Footwear
Essential Attribute	Yes For Specific GPC bricks see Essential Attribute Matrix

3.5.21 Boxed for Gift Giving

General Definition	Product is packaged in a box suitable for delivery as a gift to the recipient.
Also Known As	Gift Box
Business Example	
Business and Data Integrity Rules	Expressed as: <ul style="list-style-type: none"> ▪ Y (packaged as Boxed for Gift Giving) or ▪ N (not packaged as Boxed for Gift Giving)
Attribute Length	1 Character
Product Category	Common
Essential Attribute	No

3.5.22 Bra Band Type

General Definition	Section of the bra that fits around the wearer’s rib cage.
Also Known As	
Business Example	<ul style="list-style-type: none"> ▪ GM03BRBNST (Straight) ▪ GM03BRBNTB (T-Back)
Business and Data Integrity Rules	For a full list of values, see the Bra Band Type Code List .
Attribute Length	80 Characters
Product Category	Apparel
Essential Attribute	Yes For Specific GPC bricks see Essential Attribute Matrix

3.5.23 Bra Bust Type

General Definition	Body type the bra is designed to fit.
Also Known As	
Business Example	<ul style="list-style-type: none"> ▪ GM03BRBTAV (Average) ▪ GM03BRBTFF (Full Figure)
Business and Data Integrity Rules	For a full list of values, see the Bra Bust Type Code List .
Attribute Length	80 Characters
Product Category	Apparel
Essential Attribute	Yes For Specific GPC bricks see Essential Attribute Matrix

3.5.24 Bra Cup Coverage

General Definition	Indicates how much of the breast is covered by the cup of the bra.
Also Known As	
Business Example	<ul style="list-style-type: none"> ▪ GM03BRCCDE (Demi) ▪ GM03BRCCFL (Full)
Business and Data Integrity Rules	For a full list of values, see the Bra Cup Coverage Code List .
Attribute Length	80 Characters
Product Category	Apparel
Essential Attribute	Yes For Specific GPC bricks see Essential Attribute Matrix

3.5.25 Bra Cup Type

General Definition	Describes the characteristics of the bra cup.
Also Known As	
Business Example	<ul style="list-style-type: none"> ▪ GM03BRCTMF (Memory Foam) ▪ GM03BRCTSE (Seamless)
Business and Data Integrity Rules	For a full list of values, see the Bra Cup Type Code List . If there are multiple Bra Cup Type values, best practice is to repeat the attribute for each Bra Cup Type code that applies to the product.
Attribute Length	80 Characters
Product Category	Apparel
Essential Attribute	Yes For Specific GPC bricks see Essential Attribute Matrix

3.5.26 Bra Impact Level

General Definition	Indicates what level of sports activity of the garment.
Also Known As	
Business Example	<ul style="list-style-type: none"> ▪ GM03BRILHI (High) ▪ GM03BRILMD (Medium)
Business and Data Integrity Rules	For a full list of values, see the Bra Impact Level Code List .
Attribute Length	80 Characters
Product Category	Apparel
Essential Attribute	Yes For Specific GPC bricks see Essential Attribute Matrix

3.5.27 Bra Padding

General Definition	Provides detail about the bra padding construction.
Also Known As	
Business Example	<ul style="list-style-type: none"> ▪ GM03BRPDIP (Integrated) ▪ GM03BRPDRP (Removeable/Pocketed)
Business and Data Integrity Rules	For a full list of values, see the Bra Padding Code List .
Attribute Length	80 Characters
Product Category	Apparel
Essential Attribute	Yes For Specific GPC bricks see Essential Attribute Matrix

3.5.28 Bra Specialty Type

General Definition	Defines the specific intention of the bra's use.
Also Known As	
Business Example	<ul style="list-style-type: none"> ▪ GM03BRSTMA (Mastectomy) ▪ GM03BRSTMT (Maternity/Nursing)
Business and Data Integrity Rules	For a full list of values, see the Bra Specialty Type Code List .
Attribute Length	80 Characters
Product Category	Apparel
Essential Attribute	Yes For Specific GPC bricks see Essential Attribute Matrix

3.5.29 Bra Type

General Definition	Describes the basic features or usage of the bra.
Also Known As	
Business Example	<ul style="list-style-type: none"> ▪ GM03BRTYCN (Convertible) ▪ GM03BRTYMN (Minimizer)
Business and Data Integrity Rules	For a full list of values, see the Bra Type Code List .
Attribute Length	80 Characters
Essential for GPC brick	Bras
Product Category	Apparel
Essential Attribute	Yes For Specific GPC bricks see Essential Attribute Matrix

3.5.30 Bra Underwire

General Definition	Indicates if the bra has an underwire construction (any type of underwire applies-metal, plastic, etc.).
Also Known As	
Business Example	
Business and Data Integrity Rules	Expressed as: <ul style="list-style-type: none"> ▪ Y (has underwire) or ▪ N (does not have underwire)
Attribute Length	1 Character
Product Category	Apparel
Essential Attribute	Yes For Specific GPC bricks see Essential Attribute Matrix

3.5.31 Bracelet Type

General Definition	Description of the construction or style of a bracelet.
Also Known As	
Business Example	<ul style="list-style-type: none"> ▪ JW03BRTTCF (Cuff) ▪ JW03BRTTHN (Hinge)
Business and Data Integrity Rules	For a full list of values, see the Bracelet Type Code List .
Attribute Length	80 Characters
Product Category	Jewelry
Essential Attribute	Yes

For Specific GPC bricks see [Essential Attribute Matrix](#)

3.5.32 Brand Name

General Definition	The name used for a trade item that is recognized within the trade and by the consumer. Stylization should match the label in the garment (i.e., all lower case, all caps, special characters, etc.).
Also Known As	Label name or trade name
Business Example	<ul style="list-style-type: none"> ▪ Zita’s Apparel ▪ AJCS Designs ▪ Shiovitz Jeans
Business and Data Integrity Rules	
Attribute Length	Maximum 30 characters
Product Category	Common
Essential Attribute	Essential for ALL GPC bricks see Essential Attribute Matrix

3.5.33 Care Information

General Definition	Consumer care instructions. Representative of the care label if one is used.
Also Known As	
Business Example	<ul style="list-style-type: none"> ▪ Machine wash cold ▪ Dishwasher safe ▪ Washing & drying instructions ▪ Professional fur clean only
Business and Data Integrity Rules	Matches the consumer care instructions included with the product.
Attribute Length	Maximum 4096 characters
Product Category	Apparel, Footwear, Fashion Accessories, Home
Essential Attribute	No

3.5.34 Care Instructions Code

General Definition	Consumer care instructions codes. Representative of the care label if one is used. If a product's care instructions are not in this list or multiple codes apply, then use the freeform attribute (Care Information-3.5.20).
Also Known As	
Business Example	<ul style="list-style-type: none"> ▪ GM03CAINDC (Dry Clean Only) ▪ GM03CAINHW (Hand Wash)
Business and Data Integrity Rules	For a full list of values, see the Care Instructions Code list .
Attribute Length	80 Characters
Product Category	Apparel, Footwear, Fashion Accessories, Home
Essential Attribute	Essential for ALL GPC bricks see Essential Attribute Matrix

3.5.35 Circularity Certifications

General Definition	Certifications that demonstrate product circularity
Also Known As	
Business Example	<ul style="list-style-type: none"> ▪ GM03CICECC (Cradle to Cradle) ▪ GM04CICE99 (Other)
Business and Data Integrity Rules	If other certification is valid use Other field for free form tex
Attribute Length	80 Characters
Product Category	Apparel, Footwear, Fashion Accessories, Home
Essential Attribute	No

3.5.36 Closure

General Definition	Type of closure used in an apparel garment.
Also Known As	
Business Example	<ul style="list-style-type: none"> ▪ GM03CLOSCO (Clip On) ▪ GM03CLOSDS (Drawstring)
Business and Data Integrity Rules	<p>For a full list of values, see the Closure Code List.</p> <p><i>* If there is a closure that does not have a code, the specifications allow for a free-form text description.</i></p> <p>If there are multiple closures for an item, best practice is to describe the closures in the <i>Features – Benefits - Marketing Message</i> attribute.</p>
Attribute Length	Maximum 80 characters
Product Category	Apparel, Footwear, Jewelry, Fashion Accessories, Home
Essential Attribute	<p>Yes</p> <p>For Specific GPC bricks see Essential Attribute Matrix</p>

3.5.37 Chemical Certifications

General Definition	Product is certified with specific chemical certifications
Also Known As	
Business Example	<ul style="list-style-type: none"> ▪ GM03CHCEOT (OEKO-TEX Standard Certified 100) ▪ GM03CHCEBL (bluesign)
Business and Data Integrity Rules	For a full list of values, see the Chemical Certifications Code List
Attribute Length	Maximum 80 characters
Product Category	Common
Essential Attribute	No

3.5.38 Coat/Jacket Type

General Definition	The cut or style pertaining to the Coat/Jacket.
Also Known As	
Business Example	<ul style="list-style-type: none"> ▪ GM03COATCA (Cardigan) ▪ GM03COATFK (Field Jacket)
Business and Data Integrity Rules	For a full list of values, see the Coat/Jacket Type Code List .
Attribute Length	80 Characters
Product Category	Apparel
Essential Attribute	Yes For Specific GPC bricks see Essential Attribute Matrix

3.5.39 Color Extended Description

General Definition	An extended description that is used to provide a longer, more comprehensive description of the color.
Also Known As	
Business Example	Champagne Pink Sea Foam Green
Business and Data Integrity Rules	Freeform Text
Attribute Length	80 Characters
Product Category	Common
Essential Attribute	No

3.5.40 Collar Type

General Definition	Specific collar style for apparel items.
Also Known As	Neck shape
Business Example	<ul style="list-style-type: none"> ▪ GM03CLNTHA (Halter) ▪ GM03CLNTHN (Henley) <p>It is up to the supplier to determine which is appropriate for the associated product.</p>
Business and Data Integrity Rules	Please For a full list of values, see the Collar Type Code List . If there are multiple collar types for an item, best practice is to describe the collar types in the <i>Features – Benefits – Marketing Message</i> attribute.
Attribute Length	Maximum 80 characters
Product Category	Apparel
Essential Attribute	Yes For Specific GPC bricks see Essential Attribute Matrix

3.5.41 Conference

General Definition	An athletic conference is a collection of sports teams, playing competitively against each other at the professional, collegiate, or high school level.
Also Known As	
Business Example	<ul style="list-style-type: none"> ▪ ZZ03CONFNL (National League) ▪ ZZ03CONFNF (NFC)
Business and Data Integrity Rules	For a full list of values, see the Conference Code List .
Attribute Length	80 Characters
Product Category	Apparel, Footwear, Jewelry, Fashion Accessories, Home
Essential Attribute	No

3.5.42 Consumer Available Date

General Definition	The date the item is available for sale to the consumer.
Also Known As	
Business Example	CCYYMMDD (20130109)
Business and Data Integrity Rules	Reference the GS1 US Trade Item Identification and Communication (TIIC) Guidelines for Electronic Data Interchange .
Attribute Length	8 numeric
Product Category	Common
Essential Attribute	No

3.5.43 Consumer Item Depth

General Definition	The measurement of the consumer item from its front to its back (not including packaging).
Also Known As	

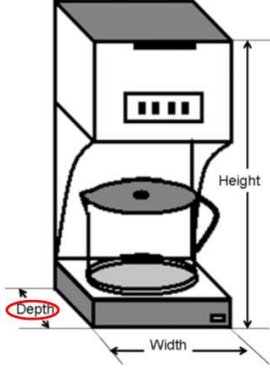

Business Example	
Business and Data Integrity Rules	Reference GS1 Package Measurement Rules .
Attribute Length	Maximum 8 numeric (optional decimal)
Product Category	Fashion Accessories, Home
Essential Attribute	No

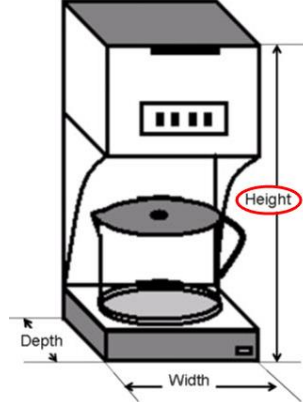
3.5.44 Consumer Item Height

General Definition	Vertical dimension of the consumer item when it is measured in the upright position (not including packaging).
Also Known As	
Business Example	
Business and Data Integrity Rules	Reference GS1 Package Measurement Rules .
Attribute Length	Maximum 8 numeric (optional decimal)
Product Category	Fashion Accessories, Home
Essential Attribute	No

3.5.45 Consumer Item Length

General Definition	Length measurement of the consumer item specific to the type of product. Refer to the specific category of the item for measurement guidance (not including packaging).
---------------------------	---

Also Known As	
Business Example	<p>Some examples for measuring consumer item length are skirt length and belt length. Specific measuring rules are found in this guide in the appropriate merchandise category. For example, dress/skirt length measurement rules are in the apparel section under Consumer Item Length.</p>  
Business and Data Integrity Rules	Reference GS1 Package Measurement Rules .
Attribute Length	Maximum 8 numeric (optional decimal)
Product Category	Apparel, Jewelry, Fashion Accessories, Home
Essential Attribute	Yes For Specific GPC bricks see Essential Attribute Matrix

3.5.46 Consumer Item Weight

General Definition	Weight of the consumer item excluding the packaging.
Also Known As	
Business Example	
Business and Data Integrity Rules	Refer to the GS1 Package Measurement Rules .
Attribute Length	Maximum 8 numeric (optional decimal)
Product Category	Common
Essential Attribute	No

3.5.47 Consumer Item Width

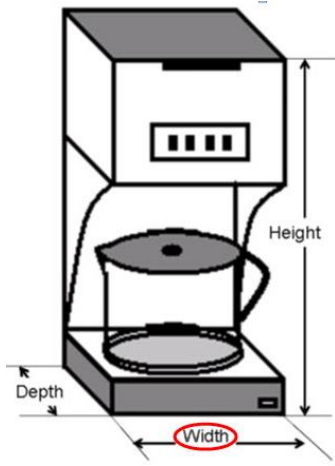
General Definition	Measurement of the consumer item from left to right (not including packaging).
Also Known As	
Business Example	
Business and Data Integrity Rules	Reference GS1 Package Measurement Rules .
Attribute Length	Maximum 8 numeric (optional decimal)
Product Category	Apparel, Jewelry, Fashion Accessories, Home
Essential Attribute	Yes For Specific GPC bricks see Essential Attribute Matrix

3.5.48 Consumer Life Stage

General Definition	Age or age group for which the product is intended.
Also Known As	Age Group
Business Example	<ul style="list-style-type: none"> ■ GM03CNLSAD (Adult) ■ GM03CNLSAG (All Ages)
Business and Data Integrity Rules	For a full list of values, see the Consumer Life Stage Code List .
Attribute Length	80 Characters
Product Category	Common
Essential Attribute for the following GPC Brick(s)	Essential for ALL GPC bricks see Essential Attribute Matrix

3.5.49 Consumer Package Depth

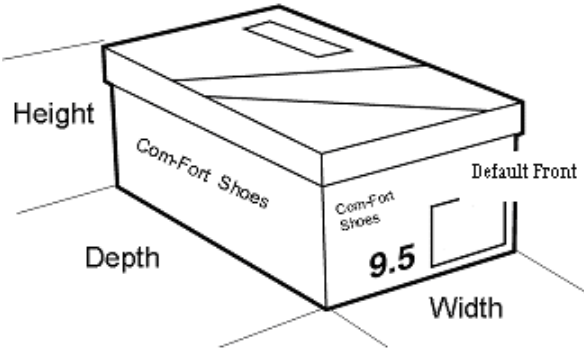
General Definition	The measurement of the package containing the consumer item from its front to the back.
Also Known As	
Business Example	
Business and Data Integrity Rules	Refer to the GS1 Package Measurement Rules . Requires the measurement value and an accompanying unit of measure.
Attribute Length	Maximum 8 numeric (optional decimal)
Product Category	Common
Essential Attribute	No

3.5.50 Consumer Package Height

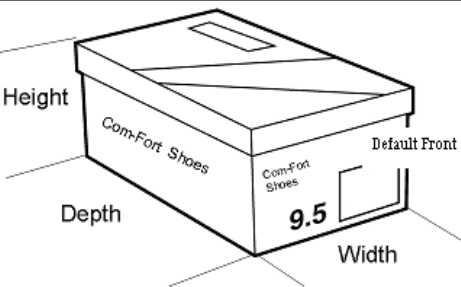
General Definition	Vertical dimension of the package containing the consumer item when in the upright position.
Also Known As	
Business Example	
Business and Data Integrity Rules	Refer to the GS1 Package Measurement Rules . Requires the measurement value and an accompanying unit of measure.
Attribute Length	Maximum 8 numeric (optional decimal)
Product Category	Common
Essential Attribute	No

3.5.51 Consumer Package Width

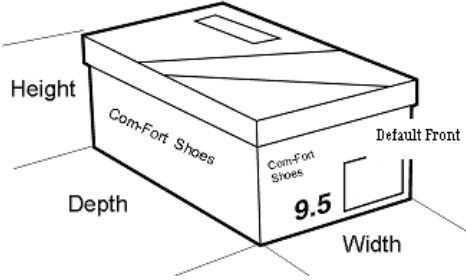
General Definition	Shorter dimension of the two horizontal dimensions of the package containing the consumer item, when in the upright position.
Also Known As	
Business Example	
Business and Data Integrity Rules	Refer to the GS1 Package Measurement Rules . Requires the measurement value and an accompanying unit of measure.
Attribute Length	Maximum 8 numeric (optional decimal)
Product Category	Common
Essential Attribute	No

3.5.52 Consumer Package Gross Weight

General Definition	Gross weight of the consumer item including the packaging.
Also Known As	
Business Example	
Business and Data Integrity Rules	Refer to the GS1 Package Measurement Rules . Requires the measurement value and an accompanying unit of measure.
Attribute Length	Maximum 8 numeric (optional decimal)
Product Category	Common
Essential Attribute	No

3.5.53 Consumer Product Capacity or Volume

General Definition	Specifies the net quantity of content or capacity of the consumer item.
Also Known As	
Business Example	<ul style="list-style-type: none"> ▪ 20 oz. pitcher ▪ 2 qt. casserole ▪ 24 oz. net weight (candy or coffee)
Business and Data Integrity Rules	
Attribute Length	Maximum 8 numeric (optional decimal)

Product Category	Beauty, Home
Essential Attribute	Yes For Specific GPC bricks see Essential Attribute Matrix

3.5.54 Consumer Quantity of Units in Consumer Package

General Definition	A measure of the unit contents within a consumer package that is identified by a single GTIN.
Also Known As	Includes consumer multi-packs.
Business Examples	<ul style="list-style-type: none"> ▪ 3 pairs of socks banded together in a single consumer package ▪ 2foot pad cushions ▪ 3 pack of hair bows ▪ 3 pack of t-shirts ▪ Set of two pairs of earrings ▪ Set of 2 replacement brush heads ▪ 18 single-serve cups of coffee ▪ 12piece glassware set ▪ 3 extra duty tennis ball in a container
Business and Data Integrity Rules	Matches the product label or packaging. Expressed as 6-character numeric value (no decimal).
Attribute Length	Maximum 6 numeric
Product Category	Common
Essential Attribute	Yes For Specific GPC bricks see Essential Attribute Matrix

3.5.55 Control Level

General Definition	Amount of support or firmness in a garment.
Also Known As	
Business Example	<ul style="list-style-type: none"> ▪ GM03CONLFR (Firm) ▪ GM03CONLMD (Medium)
Business and Data Integrity Rules	For a full list of values, see the Control Level Code List .
Attribute Length	80 Characters
Product Category	Apparel
Essential Attribute	Yes For Specific GPC bricks see Essential Attribute Matrix

3.5.56 Convertible

General Definition	Able to be changed in form, function, or character.
Also Known As	
Business Example	Pants that can convert to shorts. Jackets with removable hoods.
Business and Data Integrity Rules	Expressed as: <ul style="list-style-type: none"> ▪ Y (is convertible) or ▪ N (is not convertible)
Attribute Length	1 Character
Product Category	Apparel, Footwear, Fashion Accessories
Essential Attribute	Yes For Specific GPC bricks see Essential Attribute Matrix

3.5.57 Cookware Type

General Definition	Purpose or use of cookware.
Also Known As	
Business Example	<ul style="list-style-type: none"> ▪ GM03COOKFP (Frying Pan) ▪ GM03COOKGR (Griddle)
Business and Data Integrity Rules	For a full list of values, see the Cookware Type Code List .
Attribute Length	80 Characters
Product Category	Home
Essential Attribute	No

3.5.58 Corporate/Philanthropic Certifications

General Definition	Products are certified with a corporate and/or philanthropic certifications
Also Known As	
Business Example	<ul style="list-style-type: none"> ▪ GM03COPHPL (1% for the Planet) ▪ GM03COPHBC (BCorp Certified)
Business and Data Integrity Rules	For a full list of values, see the Corporate/Philanthropic Code List.
Attribute Length	80 Characters
Product Category	Common
Essential Attribute	No

Country of Origin

General Definition	Country where product is manufactured expressed using the 3-character ISO Country Code. Represents what is on the product label or packaging.
Also Known As	Country of Manufacture
Business Example	<ul style="list-style-type: none"> ▪ CHN (ISO country code for China) ▪ CAN (ISO country code for Canada)
Business and Data Integrity Rules	Must be expressed using the applicable ISO country code of origin list (3166-2) which is expressed as a 3-character alpha value. (See Resources links to more information on ISO codes.) For more than one country, leave a space between ISO country codes in the text stream.
Attribute Length	3 characters
Product Category	Common
Essential for the following GPC brick(s):	Essential for ALL GPC bricks see Essential Attribute Matrix

3.5.59 Covered

General Definition	Indicates if the product is covered or has a lid.
Also Known As	
Business Example	
Business and Data Integrity Rules	Expressed as: <ul style="list-style-type: none"> ▪ Y (is covered) or ▪ N (is not covered)
Attribute Length	1 Character
Product Category	Home
Essential Attribute	No

3.5.60 Consumer Product Safety Improvement Act (CPSIA)

General Definition	An indicator as to whether or not the item is in compliance with the Consumer Product Safety Improvement Act (CPSIA). This is a United States law. Reference: www.cpsc.gov/en/Business--Manufacturing/Testing-Certification/Childrens-Product-Certificate/
Also Known As	
Business Example	
Business and Data Integrity Rules	Expressed as: <ul style="list-style-type: none"> ▪ Y (the product complies with CPSIA) ▪ N (the product does not comply with CPSIA)
Attribute Length	1 character

Product Category	Common
Essential Attribute	No

3.5.61 Crown

General Definition	A baseball hat profile refers to the structure or crown on the front of the cap above the brim.
Also Known As	
Business Example	<ul style="list-style-type: none"> ▪ GM03CRWNHI (High) ▪ GM03CRWNLW (Low)
Business and Data Integrity Rules	For a full list of values, see the Crown Code List .
Attribute Length	80 Characters
Product Category	Fashion Accessories
Essential Attribute	No

3.5.62 Cuff Type

General Definition	The characteristics of the cuff of apparel items.
Also Known As	
Business Example	<ul style="list-style-type: none"> ▪ GM03CFTPFDF (Folded) ▪ GM03CFTPFR (French)
Business and Data Integrity Rules	For a full list of values, see the Cuff Type Code List .
Attribute Length	80 Characters
Product Category	Apparel
Essential Attribute	No

3.5.63 Detachable Strap

General Definition	A strap that can be used when attached to the product, or alternatively removed and the product used alone.
Also Known As	
Business Example	
Business and Data Integrity Rules	Expressed as: <ul style="list-style-type: none"> ▪ Y (has a detachable strap) or ▪ N (does not have a detachable strap)
Attribute Length	1 Character
Product Category	Apparel, Fashion Accessories, Home

Essential Attribute	Yes For Specific GPC bricks see Essential Attribute Matrix
----------------------------	---

3.5.64 Dinnerware Category

General Definition	A further classification of the dinnerware type.
Also Known As	
Business Example	<ul style="list-style-type: none"> ▪ GM03DNRCEV (Everyday) ▪ GM03DNRFCFC (Fine China)
Business and Data Integrity Rules	For a full list of values, see the Dinnerware Category Code List .
Attribute Length	80 Characters
Product Category	
Essential Attribute	No

3.5.65 Discontinue Date

General Definition	The date the item is no longer available for ordering.
Also Known As	
Business Example	CCYYMMDD (20130109)
Business and Data Integrity Rules	Reference the GS1 US Trade Item Identification and Communication (TIIC) Guidelines for Electronic Data Interchange .
Attribute Length	8 numeric
Product Category	Common
Essential Attribute	No

3.5.66 Dishwasher Safe

General Definition	Product can be cleaned in a dishwasher without negative effects on its appearance or construction.
Also Known As	
Business Example	
Business and Data Integrity Rules	Expressed as: <ul style="list-style-type: none"> ▪ Y (is dishwasher safe) or ▪ N (is not dishwasher safe)
Attribute Length	1 Character
Product Category	Home
Essential Attribute	No

3.5.67 Does Not Contain

General Definition	List of potential undesirable ingredients the product does not contain.
Also Known As	
Business Example	<ul style="list-style-type: none"> ▪ BHT ▪ FD&C Blue 1 ▪ Alcohol ▪ Sodium laurel sulphate
Business and Data Integrity Rules	
Attribute Length	Maximum 80 characters
Product Category	Beauty
Essential Attribute	No

3.5.68 Dress Type

General Definition	Indicator of the shape or use of a dress.
Also Known As	
Business Example	<ul style="list-style-type: none"> ▪ GM03DRTPFS (Full Skirt) ▪ GM03DRTPGN (Gown)
Business and Data Integrity Rules	For a full list of values, see the Dress Type Code List .
Attribute Length	80 Characters
Product Category	Apparel
Essential Attribute	Yes For Specific GPC bricks see Essential Attribute Matrix

3.5.69 Earring Drop

General Definition	The distance from the post to the bottom of the earring.
Also Known As	
Business Example	
Business and Data Integrity Rules	Requires the measurement value and the accompanying unit of measure.
Attribute Length	Maximum 8 numeric (optional decimal)

Product Category	Jewelry
Essential Attribute	Yes For Specific GPC bricks see Essential Attribute Matrix

3.5.70 Earring Type

General Definition	Indicator of the shape, length, or position worn on the ear.
Also Known As	
Business Example	<ul style="list-style-type: none"> ▪ JW03EATPHP (Hoop) ▪ JW03EATPST (Stud)
Business and Data Integrity Rules	For a full list of values, see the Earring Type Code List .
Attribute Length	80 Characters
Product Category	Jewelry
Essential Attribute	Yes For Specific GPC bricks see Essential Attribute Matrix

3.5.71 Eyewear Type

General Definition	Indicator of the shape or use of the eyewear's frame.
Also Known As	
Business Example	<ul style="list-style-type: none"> ▪ GM03EYESWA (Wayfarer) ▪ GM03EYESWR (Wrap)
Business and Data Integrity Rules	For a full list of values, see the Eyewear Type Code List .
Attribute Length	80 Characters
Product Category	Fashion Accessories
Essential Attribute	No

3.5.72 Fabric or Material Code

General Definition	Code which best describes the fabric, material, or ingredients used in the product. If the fabric or material cannot be described with a single code, use the freeform attribute Fabric or Material Description or <i>Features-Benefits-Marketing Message</i> attribute for a complete description.
Also Known As	
Business Example	<ul style="list-style-type: none"> ▪ GM03FBMCCP (Corduroy) ▪ GM03FBMCCP (Porcelain)
Business and Data Integrity Rules	For a full list of values, see the Fabric or Material Code list .
Attribute Length	80 Characters
Product Category	Apparel, Footwear, Jewelry, Fashion Accessories, Home
Essential Attribute	Essential for ALL GPC bricks For Specific GPC bricks see Essential Attribute Matrix

3.5.73 Fabric or Material Description

General Definition	Description which best describes the fabric, material, or ingredients used in the product. Includes the percentage of fibers (if applicable). Specify the fabric or material per piece if item has multiple units or use <i>Features-Benefits-Marketing Message</i> attribute for a complete description.
Also Known As	
Business Example	<ul style="list-style-type: none"> ▪ 80% cotton 20% rayon ▪ Gold plated ▪ Ceramic
Business and Data Integrity Rules	Matches the product label or packaging.
Attribute Length	Maximum 80 characters
Product Category	Apparel, Footwear, Jewelry, Fashion Accessories, Home
Essential Attribute	No

3.5.74 Faux Fur

General Definition	Designates whether the item contains faux fur. If applicable, list fabric contents and percentages in the <i>Features – Benefits - Marketing Message</i> attribute.
Also Known As	
Business Example	
Business and Data Integrity Rules	Expressed as: <ul style="list-style-type: none"> ▪ Y (is Faux Fur) or ▪ N (is not Faux Fur)
Attribute Length	1 character
Product Category	Apparel, Footwear, Jewelry, Fashion Accessories, Home
Essential Attribute	Legally Required for all GPCs if the product contains faux fur For Specific GPC bricks see Essential Attribute Matrix

3.5.75 Features – Benefits - Marketing Message

General Definition	<p>The descriptions that consumers reference on e-commerce sites to understand a product’s features and benefits. A marketing message should also be included to help consumers understand the “<i>why buy?</i>” value proposition. This attribute entices and helps sell product by providing distinctive benefits and key words that can be used in search engine optimization (SEO).</p>
Also Known As	<p>Features and Benefits, Short Product Marketing Message</p>
Business Example	 <p>Description: <i>Feel fabulous when you wrap yourself in this 32 in. luxurious fox fur coat from AJCS Designs' Elegante' series.</i></p> <p>Features:</p> <ul style="list-style-type: none"> • Outstanding Norwegian Fox Fur • Natural (untreated) • Fully lined • 32 in length • Skillfully hand crafted and hand finished • 26 in sleeve length • Made in the USA and Imported <p>A bright high-waist skirt is great this time of year. Wear with your favorite blouse for a perfect look of the season.</p> <ul style="list-style-type: none"> ▪ 61% polyester, 35% viscose, 4% cotton ▪ Dry Clean ▪ Imported ▪ Lined ▪ Length: 27 in. ▪ Zipper <p>Shiny Silver tone round stainless case watch. The watch features 3-hand movement, clear dial with 120 clear stones. Water resistant to 10 meters.</p> <ul style="list-style-type: none"> ▪ 36mm case height ▪ 3-hand movement ▪ 8 in. band circumference/length ▪ 3/4 in. band width ▪ Jewelry Clasp Closure ▪ Clear dial with 120 clear stones ▪ Water resistant to 10 ATM ▪ Imported
Business and Data Integrity Rules	<p>Free form. Field length not to exceed 4096 characters.</p>
Attribute Length	<p>Maximum 4096 characters</p>
Product Category	<p>Common</p>
Essential Attribute	<p>Essential for ALL GPC bricks For Specific GPC bricks see Essential Attribute Matrix</p>

3.5.76 Fiber

General Definition	A thread or filament from which a vegetable tissue, mineral substance, or textile is formed.
Also Known As	
Business Example	<ul style="list-style-type: none"> ▪ GM03FIBRPH (Polyester/Cotton) ▪ GM03FIBRWA (Wool)
Business and Data Integrity Rules	<p>For a full list of values, see the Fiber Code List.</p> <p>If a code represents a combination of fibers, the first listed fiber has the highest percentage of the total content. If the percentages are equal, either one can be used. For example: Polyester/Cotton (INSERT CODE VALUE), represents 60% polyester/40% cotton. If the content is 50% polyester/50% cotton, it can be represented by Polyester/Cotton (INSERT CODE VALUE) or Cotton/Polyester (INSERT CODE VALUE).</p>
Attribute Length	80 Characters
Product Category	Apparel, Footwear, Fashion Accessories, Home
Essential Attribute	<ul style="list-style-type: none"> ▪ Essential for ALL GPC bricks

3.5.77 Fill Material

General Definition	Material used to provide padding or insulation.
Also Known As	
Business Example	<ul style="list-style-type: none"> ▪ GM03FILMDW (Down) ▪ GM03FILMDA (Down Alternative)
Business and Data Integrity Rules	For a full list of values, see the Fill Material Code List .
Attribute Length	80 Characters
Product Category	Home
Essential Attribute	No

3.5.78 Finish

General Definition	Manufacturer-applied decoration or attractive surface appearance of a product.
Also Known As	
Business Example	<ul style="list-style-type: none"> ▪ GM03FNShPA (Patent) ▪ GM03FNShPL (Polished)
Business and Data Integrity Rules	For a full list of values, see the Finish Code List .
Attribute Length	80 Characters
Product Category	Apparel, Footwear, Jewelry, Home

Essential Attribute	No
----------------------------	----

3.5.79 First Available Ship Date

General Definition	The date the trade item is generally available for shipping to the trade.
Also Known As	
Business Example	CCYYMMDD (20170109)
Business and Data Integrity Rules	
Attribute Length	8 numeric
Product Category	Common
Essential Attribute	No

3.5.80 First Order Date

General Definition	The date the trade item is generally available for ordering to the trade.
Also Known As	Booking date
Business Example	CCYYMMDD (20170109)
Business and Data Integrity Rules	
Attribute Length	8 numeric
Product Category	Common
Essential Attribute	No

3.5.81 Fit

General Definition	The construction method by which a product is created.
Also Known As	
Business Example	<ul style="list-style-type: none"> ▪ GM03FITTRE (Relaxed) ▪ GM03FITTST (Structured)
Business and Data Integrity Rules	For a full list of values, see the Fit Code List .
Attribute Length	80 Characters
Product Category	Fashion Accessories
Essential Attribute	No

3.5.82 Flatware Type

General Definition	Description of specific utensil or cooking/serving accessory.
Also Known As	
Business Example	<ul style="list-style-type: none"> ▪ GM03FLATKN (Knife) ▪ GM03FLATLD (Ladle)
Business and Data Integrity Rules	For a full list of values, see the Flatware Type Code List .
Attribute Length	80 Characters
Product Category	Home
Essential Attribute	No

3.5.83 Formulation

General Definition	Indicator of the method of presenting the product or how it is applied.
Also Known As	
Business Example	<ul style="list-style-type: none"> ▪ GM03FORMGL (Gel) ▪ GM03FORMLQ (Liquid)
Business and Data Integrity Rules	For a full list of values, see the Formulation Code List .
Attribute Length	80 Characters
Product Category	Beauty
Essential Attribute	Yes For Specific GPC bricks see Essential Attribute Matrix

3.5.84 Full Product Name

General Definition	This attribute provides additional product description. Full Product Name could be used on e-commerce sites to help consumers recognize or search for products. It also provides additional information for buyers identifying products. Full Product Name could also be used in conjunction with the Brand Name to describe the product for e-commerce.
Also Known As	Extended Description
Business Example	 <ul style="list-style-type: none"> ▪ Norwegian Fox Fur Coat ▪ Single Milled Cotton Bath Towel ▪ Fresh Water Pearl Drop Earring ▪ Embroidered Lace Skirt
Business and Data Integrity Rules	
Attribute Length	Maximum 40 characters
Product Category	Common
Essential Attribute	No

3.5.85 Fur Animal Name

General Definition	The name of the animal whose fur was used in a garment. Should include all genuine fur and animal hair.
Also Known As	
Business Example	<ul style="list-style-type: none"> ▪ GM03FANMRC (Raccoon) ▪ GM03FANMSG (Sable)
Business and Data Integrity Rules	<p>For a full list of values, see the Fur Animal Name Code List.</p> <p><i>* If there is an animal name that does not have a code, the specifications allow for a free-form text description.</i></p> <p>If there are multiple animal names for an item, best practice is to describe the animal names in the <i>Features – Benefits – Marketing Message</i> attribute.</p>
Attribute Length	Maximum 80 characters
Product Category	Apparel, Footwear, Jewelry, Fashion Accessories, Home
Essential Attribute	<p>Legally required for ALL GPC's if product contains fur</p> <p>For Specific GPC bricks see Essential Attribute Matrix</p>

3.5.86 Fur Country of Origin

General Definition	Country of origin for an imported fur product. This includes country of origin for imported furs made into fur products in the U.S. and Canada. Expressed using the 3-character ISO Country Code. (See Resources for links to more information on ISO codes.)
Also Known As	
Business Example	<ul style="list-style-type: none"> ▪ USA ▪ CAN
Business and Data Integrity Rules	Use 3-character ISO country code. For more than one country, leave a space between ISO country codes in the text stream.
Attribute Length	3 characters
Product Category	Apparel, Footwear, Jewelry, Fashion Accessories, Home
Essential Attribute	<ul style="list-style-type: none"> ▪ Legally required for ALL GPC's if product contains fur

3.5.87 Fur Treatment

General Definition	Indicates if the fur is painted, dyed, bleached, artificially colored, or natural (untreated).
Also Known As	
Business Example	<ul style="list-style-type: none"> ▪ GM03FTMTBM (Bleached) ▪ GM03FTMTDY (Dyed)
Business and Data Integrity Rules	For a full list of values, see the Fur Treatment Code List . * If there is a fur treatment that does not have a code, the specifications allow for a free form text description. If there are multiple fur treatments for an item, best practice is to describe the fur treatments in the <i>Features – Benefits – Marketing Message</i> attribute.
Attribute Length	Maximum 80 characters
Product Category	Apparel, Footwear, Jewelry, Fashion Accessories, Home
Essential Attribute	Legally required for ALL GPC's if product contains fur For Specific GPC bricks see Essential Attribute Matrix

3.5.88 Gauge

General Definition	The thickness, size or capacity of fabric based off the stitches per inch.
Also Known As	
Business Example	<ul style="list-style-type: none"> ▪ GM03GAUGFI (Fine) ▪ GM03GAUGHV (Heavy)
Business and Data Integrity Rules	For a full list of values, see the Gauge Code List .
Attribute Length	80 Characters

Product Category	Apparel, Fashion Accessories, Home
Essential Attribute	Yes For Specific GPC bricks see Essential Attribute Matrix

3.5.89 Gender

General Definition	The intended gender(s) for which a product is intended.
Also Known As	
Business Example	<ul style="list-style-type: none"> ▪ ZZ03GENDFE (Female) ▪ ZZ03GENDMA (Male)
Business and Data Integrity Rules	For a full list of values, see the Gender Code List .
Attribute Length	80 Characters
Product Category	Common
Essential Attribute	Essential for ALL GPC bricks For Specific GPC bricks see Essential Attribute Matrix

3.5.90 Global Product Classification (GPC)

General Definition	Global Product Classification (GPC) code at the brick level used to identify the product type.																																										
Also Known As	GPC Brick, Classification, Product Type																																										
Business Example	<p>Common merchandise examples as of April 2017 are listed below.</p> <table border="1" data-bbox="602 478 1502 961"> <thead> <tr> <th>Product</th> <th>Brick Code</th> <th>Brick Description</th> </tr> </thead> <tbody> <tr> <td>Eyeshadow</td> <td>10000533</td> <td>Cosmetics – Eyes</td> </tr> <tr> <td>Perfume Spray</td> <td>10000365</td> <td>Fragrances</td> </tr> <tr> <td>Home Soda Maker</td> <td>10002016</td> <td>Carbonated Drinks Makers</td> </tr> <tr> <td>Bone China Dinner Plate</td> <td>10002153</td> <td>Plates (Non-Disposable)</td> </tr> <tr> <td>Performance Women’s Running Shoe</td> <td>10001070</td> <td>Athletic Footwear – General Purpose</td> </tr> <tr> <td>Shoe Polish Kit</td> <td>10000400</td> <td>Shoe Cleaning/Care Preparations</td> </tr> <tr> <td>Diamond Ear Crawler</td> <td>10001087</td> <td>Earrings/Body-piercing Jewelry</td> </tr> <tr> <td>Braided Web Belt</td> <td>10001326</td> <td>Belts/Braces/Cummerbunds</td> </tr> <tr> <td>S/S Wrap Dress</td> <td>10001333</td> <td>Dresses</td> </tr> <tr> <td>Captain America Tee</td> <td>10001352</td> <td>Shirts/Blouses/Polo Shirts/T-shirts</td> </tr> <tr> <td>Plastic Connect Blocks</td> <td>10005166</td> <td>Toy Building Blocks (Non-Powered)</td> </tr> <tr> <td>Sunset Duvet Cover</td> <td>10002223</td> <td>Duvet Covers</td> </tr> <tr> <td>Leather Satchel Handbag</td> <td>10001096</td> <td>Handbags/Shoulder Bags</td> </tr> </tbody> </table>	Product	Brick Code	Brick Description	Eyeshadow	10000533	Cosmetics – Eyes	Perfume Spray	10000365	Fragrances	Home Soda Maker	10002016	Carbonated Drinks Makers	Bone China Dinner Plate	10002153	Plates (Non-Disposable)	Performance Women’s Running Shoe	10001070	Athletic Footwear – General Purpose	Shoe Polish Kit	10000400	Shoe Cleaning/Care Preparations	Diamond Ear Crawler	10001087	Earrings/Body-piercing Jewelry	Braided Web Belt	10001326	Belts/Braces/Cummerbunds	S/S Wrap Dress	10001333	Dresses	Captain America Tee	10001352	Shirts/Blouses/Polo Shirts/T-shirts	Plastic Connect Blocks	10005166	Toy Building Blocks (Non-Powered)	Sunset Duvet Cover	10002223	Duvet Covers	Leather Satchel Handbag	10001096	Handbags/Shoulder Bags
Product	Brick Code	Brick Description																																									
Eyeshadow	10000533	Cosmetics – Eyes																																									
Perfume Spray	10000365	Fragrances																																									
Home Soda Maker	10002016	Carbonated Drinks Makers																																									
Bone China Dinner Plate	10002153	Plates (Non-Disposable)																																									
Performance Women’s Running Shoe	10001070	Athletic Footwear – General Purpose																																									
Shoe Polish Kit	10000400	Shoe Cleaning/Care Preparations																																									
Diamond Ear Crawler	10001087	Earrings/Body-piercing Jewelry																																									
Braided Web Belt	10001326	Belts/Braces/Cummerbunds																																									
S/S Wrap Dress	10001333	Dresses																																									
Captain America Tee	10001352	Shirts/Blouses/Polo Shirts/T-shirts																																									
Plastic Connect Blocks	10005166	Toy Building Blocks (Non-Powered)																																									
Sunset Duvet Cover	10002223	Duvet Covers																																									
Leather Satchel Handbag	10001096	Handbags/Shoulder Bags																																									
Business and Data Integrity Rules	<p>Refer to the GS1 Global Product Code (GPC) tables to select the product class brick for the product details. For a summary of brick codes which may apply to General Merchandise and Apparel, refer to the AGM list provided on the GS1 US website (which is valid as of May 2022 and intended as a quick reference). Please consult the GPC Browser for the most current and complete list of codes.</p> <p>The GPC Browser can be used to search for codes. Here is an example of a search:</p> <p style="color: #800080;">General Purpose Footwear Brick: 100001076 - Boots - General Purpose</p> <div data-bbox="716 1192 1382 1751" style="border: 1px solid #ccc; padding: 10px;"> <p>Family: <input type="text" value="Footwear"/> ▼</p> <p>Class: <input type="text" value="General Purpose Footwear"/> ▼</p> <p>Search: <input type="text"/> <input type="text" value="Brick"/> ▼</p> <p><input type="checkbox"/> Exact wording <input type="button" value="Search"/></p> <p style="text-align: center;">Expand All Brick Class Family Collapse All</p> <p>[-] Segment: 63000000 - Footwear</p> <p style="padding-left: 20px;">[-] Family: 63010000 - Footwear</p> <p style="padding-left: 40px;">+ Class: 63010100 - Athletic Footwear</p> <p style="padding-left: 40px;">+ Class: 63010200 - Footwear Accessories</p> <p style="padding-left: 40px;">[-] Class: 63010300 - General Purpose Footwear</p> <p style="padding-left: 60px;">+ Brick: 10001076 - Boots – General Purpose</p> <p style="padding-left: 60px;">+ Brick: 10001077 - Shoes – General Purpose</p> <p style="padding-left: 40px;">+ Class: 63010400 - Indoor Footwear</p> <p style="padding-left: 40px;">+ Class: 63010500 - Safety/Protective Footwear</p> </div>																																										
Attribute Length	16 Numeric																																										
Product Category	Common																																										

Essential Attribute	Essential for ALL Attributes For Specific GPC bricks see Essential Attribute Matrix
----------------------------	--

3.5.91 Glove Type

General Definition	Products worn over the hands for protection from cold or dirt. Typically have separate openings for the fingers and thumb
Also Known As	
Business Example	<ul style="list-style-type: none"> ▪ GM03GLTYMI (Mitten) ▪ GM03GLTYFI (Fingerless)
Business and Data Integrity Rules	For a full list of values, see the Glove Type Code List
Attribute Length	80 characters
Product Category	Apparel, Accessories
Essential Attribute	Yes For Specific GPC bricks see Essential Attribute Matrix

3.5.92 Gold Karat

General Definition	Amount of gold in a particular item. Karats are measured in units of 24: <ul style="list-style-type: none"> ▪ 24 karat gold is pure gold ▪ 18 karat gold is 18 parts gold and 6 parts alloys such as copper, nickel, silver, or zinc ▪ 14 karat gold is 14 parts gold and 10 parts alloy
Also Known As	
Business Example	
Business and Data Integrity Rules	Requires an accompanying unit of measure.
Attribute Length	Maximum 20 numeric (including decimal)
Product Category	Jewelry
Essential Attribute	No

3.5.93 Hand Painted

General Definition	The product contains hand-painting on one or more of its surfaces.
Also Known As	
Business Example	
Business and Data Integrity Rules	Expressed as: <ul style="list-style-type: none"> ▪ Y (is Hand Painted) or ▪ N (is not Hand Painted)
Attribute Length	1 Character
Product Category	Home
Essential Attribute	No

3.5.94 Handbag Shoulder Drop

General Definition	The measurement of the strap or handle from the top of the bag to the peak of the strap or handle.
Also Known As	
Business Example	
Business and Data Integrity Rules	Requires the measurement value and accompanying unit of measure.
Attribute Length	Maximum 8 numeric (optional decimal)
Product Category	Fashion Accessories
Essential Attribute	Yes For Specific GPC bricks see Essential Attribute Matrix

3.5.95 Handle Strap

General Definition	Defines if a product contains a handle strap.
Also Known As	
Business Example	
Business and Data Integrity Rules	Expressed as: <ul style="list-style-type: none"> ▪ Y (has a Handle Strap) or ▪ N (does not have a Handle Strap)
Attribute Length	1 Character

Product Category	Fashion Accessories
Essential Attribute	Yes For Specific GPC bricks see Essential Attribute Matrix

3.5.96 Handmade

General Definition	Made by hand, not by machine.
Also Known As	
Business Example	
Business and Data Integrity Rules	Expressed as: <ul style="list-style-type: none"> ▪ Y (is Handmade) or ▪ N (is not Handmade)
Attribute Length	1 Character
Product Category	Common
Essential Attribute	No

3.5.97 Harmonized Tariff Schedule Code

General Definition	The classification as defined by the Harmonized Tariff Schedule of each customs jurisdiction.
Also Known As	Harmonized System Code
Business Example	US HTS Example: 3105.51.0000 Footwear with outer soles of leather or composition leather
Business and Data Integrity Rules	Defined code list. Consult with relevant Customs jurisdictions. <ul style="list-style-type: none"> ▪ For the US, this is a 10-digit numeric value: https://www.usitc.gov/publications/docs/tata/hts/bychapter/1202qn.pdf ▪ For Canada: www.cbsa-asfc.gc.ca/trade-commerce/tariff-tarif/menu-eng.html
Attribute Length	Maximum 30 characters
Product Category	Common
Essential Attribute	Essential for ALL GPC bricks For Specific GPC bricks see Essential Attribute Matrix

3.5.98 Hat Type

General Definition	Indicator of the shape or use of the hat/headwear.
Also Known As	
Business Example	<ul style="list-style-type: none"> ▪ GM03HATSBN (Bonnet) ▪ GM03HATSBW (Bowler)
Business and Data Integrity Rules	For a full list of values, see the Hat Type Code List .
Attribute Length	80 Characters
Product Category	Fashion Accessories
Essential Attribute	Yes For Specific GPC bricks see Essential Attribute Matrix

3.5.99 Hazardous Material Class Code

General Definition	Code that denotes that contents are hazardous materials and what type.
Also Known As	CAS/UN/NA- number
Business Example	<ul style="list-style-type: none"> ▪ Aerosols, flammable, (each not exceeding 1 L capacity): Code 1950 ▪ Lithium metal batteries including lithium alloy batteries: Code 3090
Business and Data Integrity Rules	<ul style="list-style-type: none"> ▪ US: Hazardous materials identification code per the U.S. Department of Transportation (DOT): http://www.hazmattool.com/index.php. Please review the entire list to determine the proper code to be used. ▪ Canada: Environmental and workplace health is administered by Health Canada. Reference the Workplace Hazardous Materials Information System: www.hc-sc.gc.ca/ewh-semt/occup-travail/whmis-simdut/index-eng.php
Attribute Length	Maximum 4 characters
Product Category	Beauty, Home
Essential Attribute	Legally required for ALL GPC bricks if product contains hazardous materials For Specific GPC bricks see Essential Attribute Matrix

3.5.100 Hazardous Material Description

General Definition	Text description of hazardous material content and type.
Also Known As	
Business Example	<ul style="list-style-type: none"> ▪ Aerosol, flammable ▪ Lithium metal batteries including lithium alloy batteries
Business and Data Integrity Rules	
Attribute Length	Maximum 80 characters

Product Category	Beauty, Home
Essential Attribute	Legally required for ALL GPC bricks if product contains hazardous materials For Specific GPC bricks see Essential Attribute Matrix

3.5.101 Heel Height

General Definition	Numeric measurement of the heel is taken at the outsole, from the middle of the heel to the sole. If there is no heel, indicate 0 for the measurement.
Also Known As	
Business Example	
Business and Data Integrity Rules	Requires the measurement value and an accompanying unit of measure.
Attribute Length	Maximum 8 numeric (optional decimal)
Product Category	Footwear
Essential Attribute	Yes For Specific GPC bricks see Essential Attribute Matrix

3.5.102 Heel Height Range

General Definition	The range in which the heel height of a shoe pertains.
Also Known As	
Business Example	<ul style="list-style-type: none"> ▪ GM03HLHTEH (Extra-High > 3 inch) ▪ GM03HLHTFL (Flat - 0-.5 inch)
Business and Data Integrity Rules	For a full list of values, see the Heel Height Range Code List .
Attribute Length	80 Characters
Product Category	Footwear
Essential Attribute	No









3.5.103 Heel Material

General Definition	The material(s) used in the construction of the heel of a shoe.
Also Known As	
Business Example	<ul style="list-style-type: none"> ▪ GM03HLMTSY (Synthetic)

	<ul style="list-style-type: none"> GM03HLMTWD (Wood)
Business and Data Integrity Rules	For a full list of values, see the Heel Material Code List .
Attribute Length	80 Characters
Product Category	Footwear
Essential Attribute	No

3.5.104

Heel Type

General Definition	The primary construction form of the heel of a shoe.
Also Known As	
Business Example	<ul style="list-style-type: none"> GM03HLTYSL (Stiletto/Pointed) GM03HLTYWE (Wedge) <div style="display: flex; flex-wrap: wrap; justify-content: space-around; text-align: center;"> <div style="width: 30%;"> <p>KITTEN HEEL</p>  </div> <div style="width: 30%;"> <p>COMMA HEEL</p>  </div> <div style="width: 30%;"> <p>CONE HEEL</p>  </div> <div style="width: 30%;"> <p>FLAT HEEL</p>  </div> <div style="width: 30%;"> <p>LOUIS FLARED HEEL</p>  </div> <div style="width: 30%;"> <p>SPOOL HEEL</p>  </div> <div style="width: 30%;"> <p>STACKED HEEL</p>  </div> <div style="width: 30%;"> <p>STILETTO HEEL</p>  </div> <div style="width: 30%;"> <p>WEDGE HEEL</p>  </div> </div>
Business and Data Integrity Rules	For a full list of values, see the Heel Type Code List .
Attribute Length	80 Characters
Product Category	Footwear
Essential Attribute	No

3.5.105 Holiday/Event

General Definition	Describes the holiday for which the product is intended.
Also Known As	
Business Example	<ul style="list-style-type: none"> ▪ ZZ03HOEVMD (Mother’s Day) ▪ ZZ03HOEVNY (New Year’s)
Business and Data Integrity Rules	For a full list of values, see the Holiday/Event Code List .
Attribute Length	80 Characters
Product Category	Common
Essential Attribute	No

3.5.106 Hooded

General Definition	Whether or not the product has an attached or detachable hood.
Also Known As	
Business Example	
Business and Data Integrity Rules	Expressed as: <ul style="list-style-type: none"> ▪ Y (is Hooded) or ▪ N (is not Hooded)
Attribute Length	1 Character
Product Category	Apparel
Essential Attribute	Yes For Specific GPC bricks see Essential Attribute Matrix

3.5.107 Hosiery/Sock Type

General Definition	Indicates the use or length of sock or hosiery.
Also Known As	
Business Example	<ul style="list-style-type: none"> ▪ GM03HOSOKH (Knee Highs) ▪ GM03HOSOLG (Leggings)
Business and Data Integrity Rules	For a full list of values, see the Hosiery/Sock Type Code List .
Attribute Length	80 Characters
Product Category	Fashion Accessories
Essential Attribute	Yes For Specific GPC bricks see Essential Attribute Matrix

3.5.108

Hypoallergenic

General Definition	Relatively unlikely to cause an allergic response.
Also Known As	
Business Example	
Business and Data Integrity Rules	Expressed as: <ul style="list-style-type: none"> ▪ Y (is Hypoallergenic) or ▪ N (is not Hypoallergenic)
Attribute Length	1 Character
Product Category	Beauty, Home
Essential Attribute	Yes For Specific GPC bricks see Essential Attribute Matrix

3.5.109

Ingredients

General Definition	The complete listing of all ingredients of the trade item.
Also Known As	List of Ingredients
Business Example	<ul style="list-style-type: none"> ▪ Mineral Oil ▪ Water ▪ Colorants ▪ Silica ▪ Talc ▪ Fragrance
Business and Data Integrity Rules	Free form text
Attribute Length	80 Characters
Product Category	Beauty
Essential Attribute	Yes For Specific GPC bricks see Essential Attribute Matrix

3.5.110 Inner Pack Quantity

General Definition	Indicates the number of physical groupings (inner packs) of next lower-level trade items within the current GTIN level.
Also Known As	
Business Example	100 packages of socks, with 6 pairs in each sellable package: the Inner Pack Quantity would be 6.
Business and Data Integrity Rules	
Attribute Length	Maximum 8 numeric
Product Category	Common
Essential Attribute	No

3.5.111 Insulated

General Definition	The product is protected by interposing material that prevents the loss of heat or cold.
Also Known As	
Business Example	
Business and Data Integrity Rules	Expressed as: <ul style="list-style-type: none"> ▪ Y (is Insulated) or ▪ N (is not Insulated)
Attribute Length	1 Character
Product Category	Footwear, Home
Essential Attribute	No

3.5.112 Jewelry Sets

General Definition	Types of jewelry sets.
Also Known As	
Business Example	<ul style="list-style-type: none"> ▪ JW03JWSTBE (Bracelet/Ears) ▪ JW03JWSTNE (Neck/Ears)
Business and Data Integrity Rules	For a full list of values, see the Jewelry Sets Code List .
Attribute Length	80 Characters
Product Category	Jewelry
Essential Attribute	No

3.5.113 Jewelry Type

General Definition	Relative quality level of metal and stones used to construct a jewelry product.
Also Known As	
Business Example	<ul style="list-style-type: none"> ▪ JW03JWLTCS (Costume) ▪ JW03JWLTFA (Fashion)
Business and Data Integrity Rules	For a full list of values, see the Jewelry Type Code List .
Attribute Length	80 Characters
Product Category	Jewelry
Essential Attribute	Yes For Specific GPC bricks see Essential Attribute Matrix

3.5.114 Key-Active Ingredients

General Definition	List of key or active ingredients.
Also Known As	
Business Example	<ul style="list-style-type: none"> ▪ Amino acids ▪ Algae Extracts ▪ Aloe Vera ▪ Organic green tea oil
Business and Data Integrity Rules	
Attribute Length	Maximum 80 characters
Product Category	Beauty
Essential Attribute	Yes For Specific GPC bricks see Essential Attribute Matrix

3.5.115 Knit Type

General Definition	The type of knit used to construct the product.
Also Known As	
Business Example	<ul style="list-style-type: none"> ▪ GM03KNITPM (Pom) ▪ GM03KNITTA (Tassel)
Business and Data Integrity Rules	For a full list of values, see the Knit Type Code List .
Attribute Length	80 Characters
Product Category	Apparel, Fashion Accessories
Essential Attribute	No

3.5.116

Laser Cut

General Definition	Indicates the item is cut precisely via a method using a laser.
Also Known As	
Business Example	
Business and Data Integrity Rules	Expressed as: <ul style="list-style-type: none"> ▪ Y (is Laser Cut) or ▪ N (is not Laser Cut)
Attribute Length	1 Character
Product Category	Apparel, Footwear, Jewelry, Fashion Accessories, Home
Essential Attribute	Yes For Specific GPC bricks see Essential Attribute Matrix

3.5.117

Lead Time

General Definition	Estimated number of days to delivery after the purchase order is placed.
Also Known As	
Business Example	
Business and Data Integrity Rules	Expressed in calendar days
Attribute Length	Maximum 3 numeric
Product Category	Common
Essential Attribute	No

3.5.118

League

General Definition	A group of sports teams that play each other over a period for a championship.
Also Known As	
Business Example	<ul style="list-style-type: none"> ▪ ZZ03LEAGNF (NFL) ▪ ZZ03LEAGNH (NHL)
Business and Data Integrity Rules	For a full list of values, see the League Code List .
Attribute Length	80 Characters
Product Category	Apparel, Footwear, Jewelry, Fashion Accessories, Home
Essential Attribute	No

3.5.119

Leather Animal Name

General Definition	The name of the animal whose leather was used in a garment. Should include all genuine leather.
Also Known As	
Business Example	<ul style="list-style-type: none"> ▪ GM03LEANAL (Alligator) ▪ GM03LEANBU (Buffalo)
Business and Data Integrity Rules	For a full list of values, please see Leather Animal Name Code List . If this attribute does not have a code, the specifications allow for free form text.
Attribute Length	80 Characters
Product Category	Apparel, Footwear, Fashion Accessories, Home
Essential Attribute	No

3.5.120

Leg Type

General Definition	The style pertaining to the leg of a pant.
Also Known As	
Business Example	<ul style="list-style-type: none"> ▪ GM03LGTYBC (Boot Cut) ▪ GM03LGTYFL (Flare Leg)
Business and Data Integrity Rules	For a full list of values, please see Leg Type Code List . If this attribute does not have a code, the specifications allow for free form text.
Attribute Length	80 Characters
Product Category	Apparel
Essential Attribute	Yes For Specific GPC bricks see Essential Attribute Matrix

3.5.121 Length Description

General Definition	The relative length description of a product.
Also Known As	
Business Example	<ul style="list-style-type: none"> ▪ GM03LNTHMN (Mini) ▪ GM03LNTHRF (Regular/Full)
Business and Data Integrity Rules	For a full list of values, see the Length Description Code List .
Attribute Length	80 Characters
Product Category	Apparel
Essential Attribute	Yes For Specific GPC bricks see Essential Attribute Matrix

3.5.122 Lined

General Definition	Indicator of how much the lining covers the product's interior.
Also Known As	
Business Example	GM03LINDFL (Fully Lined)
Business and Data Integrity Rules	For a full list of values, see the Lined Code List .
Attribute Length	
Product Category	Apparel, Fashion Accessories, Footwear, Home
Essential Attribute	Yes For Specific GPC bricks see Essential Attribute Matrix

3.5.123 Lining Material

General Definition	Indicates the type of material the lining is made from.
Also Known As	
Business Example	<ul style="list-style-type: none"> ▪ GM03LIMTFD (Fabric) ▪ GM03LIMTFB (Faux Fur)
Business and Data Integrity Rules	For a full list of values, see the Lining Material Code List . If there are multiple linings for an item, best practice is to describe the lining materials in the <i>Features – Benefits - Marketing Message</i> attribute.
Attribute Length	Maximum 80 characters
Product Category	Apparel, Footwear, Fashion Accessories, Home
Essential Attribute	Yes For Specific GPC bricks see Essential Attribute Matrix

3.5.124 Marked Retail Price

General Definition	Indicator of whether or not the product is marked with a retail price.
Also Known As	Is ticketed with retail, Retail marked
Business Example	
Business and Data Integrity Rules	Expressed as: <ul style="list-style-type: none"> ▪ Y (is marked with a retail price) or ▪ N (is not marked with a retail price)
Attribute Length	80 Characters
Product Category	Common
Essential Attribute	No

3.5.125 Material Country of Origin

General Definition	The ISO 3-character code representing the country of origin(s) for the materials used to create the trade item.
Also Known As	
Business Example	<ul style="list-style-type: none"> ▪ CHN (ISO country code for China) ▪ CAN (ISO country code for Canada)
Business and Data Integrity Rules	Must be expressed using the applicable ISO count code of origin list (3166-2) which is expressed as a 3-character alpha value. (See below for links to more information on ISO codes.) For more than one country code, leave a space between ISO country codes in the text stream.
Attribute Length	80 characters
Product Category	Common
Essential Attribute	No

3.5.126 Maternity

General Definition	Product suited for pregnancy.
Also Known As	
Business Example	
Business and Data Integrity Rules	Expressed as: <ul style="list-style-type: none"> ▪ Y (is for Maternity) or ▪ N (is not for Maternity)
Attribute Length	1 Character
Product Category	Apparel
Essential Attribute	No

3.5.127

Metal

General Definition	The metal composition of the product.
Also Known As	
Business Example	<ul style="list-style-type: none"> ▪ JW03METLRG (Rose Gold) ▪ JW03METLAG (Silver)
Business and Data Integrity Rules	For a full list of values, see the Metal Code List .
Attribute Length	80 Characters
Product Category	Jewelry
Essential Attribute	No

3.5.128

Metal Composition

General Definition	The metal composition of stainless-steel flatware.
Also Known As	
Business Example	<ul style="list-style-type: none"> ▪ GM03MTLCCA (18/0) ▪ GM03MTLCCB (18/10)
Business and Data Integrity Rules	For a full list of values, see the Metal Composition Code List .
Attribute Length	80 Characters
Product Category	Home
Essential Attribute	No

3.5.129

Metal Feet

General Definition	An indicator that product contains metal feet.
Also Known As	
Business Example	
Business and Data Integrity Rules	Expressed as: <ul style="list-style-type: none"> ▪ Y (has Metal Feet) or ▪ N (does not have Metal Feet)
Attribute Length	1 Character
Product Category	Fashion Accessories
Essential Attribute	Yes For Specific GPC bricks see Essential Attribute Matrix

3.5.130 Microwave Safe

General Definition	An indicator that the product is microwave safe.
Also Known As	
Business Example	
Business and Data Integrity Rules	Expressed as: <ul style="list-style-type: none"> ▪ Y (is Microwave Safe) or ▪ N (is not Microwave Safe)
Attribute Length	1 Character
Product Category	Home
Essential Attribute	No

3.5.131 Minimum Order Quantity

General Definition	The minimum quantity of the orderable trade item that can be ordered. This applies to each individual order.
Also Known As	
Business Example	
Business and Data Integrity Rules	Expressed as a number or a count.
Attribute Length	Maximum 15 numeric (optional decimal)
Product Category	Common
Essential Attribute	No

3.5.132 Necklace Type

General Definition	Indicator of the length or adornment of a necklace.
Also Known As	
Business Example	<ul style="list-style-type: none"> ▪ JW03NKLCP (Pearl Strand) ▪ JW03NKLCP (Pendant)
Business and Data Integrity Rules	For a full list of values, see the Necklace Type Code List .
Attribute Length	80 Characters
Product Category	Jewelry
Essential Attribute	Yes For Specific GPC bricks see Essential Attribute Matrix

3.5.133 Neckwear Type

General Definition	Indicator of the shape or use of the neckwear.
Also Known As	
Business Example	<ul style="list-style-type: none"> ▪ GM03NECKBN (Bandana) ▪ GM03NECKBA (Boa)
Business and Data Integrity Rules	For a full list of values, see the Neckwear Type Code List .
Attribute Length	80 Characters
Product Category	Fashion Accessories
Essential Attribute	Yes For Specific GPC bricks see Essential Attribute Matrix

3.5.134 Number of Settings

General Definition	Number of advertised settings for the product.
Also Known As	
Business Example	<ul style="list-style-type: none"> ▪ GM03SETSEI (Eight) ▪ GM03SETSFR (Four)
Business and Data Integrity Rules	For a full list of values, see the Number of Settings Code List .
Attribute Length	80 Characters
Product Category	Home
Essential Attribute	No

3.5.135 Occasion

General Definition	An event for which the product is designed.
Also Known As	
Business Example	<ul style="list-style-type: none"> ▪ GM03OCCNGG (Graduation) ▪ GM03OCCNGM (Groom)
Business and Data Integrity Rules	For a full list of values, see the Occasion Code List . If there are multiple Occasions, best practice is to repeat the attribute for each Occasion code that applies to the product.
Attribute Length	80 Characters
Product Category	Common
Essential Attribute	No

3.5.136

Officially Licensed

General Definition	An indicator that the product has been officially licensed.
Also Known As	
Business Example	
Business and Data Integrity Rules	Expressed as: <ul style="list-style-type: none"> ▪ Y (is an Officially Licensed product) or ▪ N (is not an Officially Licensed product)
Attribute Length	1 Character
Product Category	Apparel, Footwear, Jewelry, Fashion Accessories, Home
Essential Attribute	No

3.5.137

Oil Free

General Definition	An indicator that the product does not contain any form of oil.
Also Known As	
Business Example	
Business and Data Integrity Rules	Expressed as: <ul style="list-style-type: none"> ▪ Y (is Oil Free) or ▪ N (contains Oil)
Attribute Length	1 Character
Product Category	Beauty
Essential Attribute	Yes For Specific GPC bricks see Essential Attribute Matrix

3.5.138

Open/Closed Toe

General Definition	Describes if the toe of the shoe is enclosed or open in any way where the toes area visible.
Also Known As	
Business Example	<ul style="list-style-type: none"> ▪ (Closed) ▪ (Open)
Business and Data Integrity Rules	For a full list of values, see the Open/Closed Code List .
Attribute Length	80 Characters
Product Category	Footwear
Essential Attribute	Yes For Specific GPC bricks see Essential Attribute Matrix

3.5.139 Order Quantity Multiple

General Definition	Product must be ordered in multiples of the quantity specified.
Also Known As	Multiple order quantity
Business Example	If order quantity multiple is 5, an order can be placed for 5, 10, 15, or any other multiple of 5.
Business and Data Integrity Rules	Expressed as a number
Attribute Length	Maximum 15 numeric (optional decimal)
Product Category	Common
Essential Attribute	No

3.5.140 Outsole Type

General Definition	Specifies the type of outsole.
Also Known As	
Business Example	<ul style="list-style-type: none"> ▪ GM03OUTSDP (Dimpled) ▪ GM03OUTSDR (Driver)
Business and Data Integrity Rules	For a full list of values, see the Outsole Type Code List .
Attribute Length	80 Characters
Product Category	Footwear
Essential Attribute	No

3.5.141 Padded

General Definition	An indicator that the product is padded with extra material.
Also Known As	
Business Example	
Business and Data Integrity Rules	Expressed as: <ul style="list-style-type: none"> ▪ Y (is Padded) or ▪ N (is not Padded)
Attribute Length	1 Character
Product Category	Fashion Accessories
Essential Attribute	No

3.5.142 Pant / Inseam Length

General Definition	Measurement of garment from the bottom of crotch to the bottom of hemline.
---------------------------	--

Also Known As	
Business Example	
Business and Data Integrity Rules	Requires the measurement value and an accompanying unit of measure.
Attribute Length	Maximum of 20 numeric (including decimal)
Product Category	Apparel
Essential Attribute	Yes For Specific GPC bricks see Essential Attribute Matrix

3.5.143

Pants/Shorts Type

General Definition	The style of pants or shorts.
Also Known As	
Business Example	<ul style="list-style-type: none"> ▪ GM03PTSHSK (Skort) ▪ GM03PTSHSW (Sweatpant)
Business and Data Integrity Rules	For a full list of values, see the Pants/Shorts Type Code List .
Attribute Length	80 Characters
Product Category	Apparel
Essential Attribute	Yes For Specific GPC bricks see Essential Attribute Matrix

3.5.144

Panty Back Coverage

General Definition	Coverage provided by the panty type.
Also Known As	
Business Example	<ul style="list-style-type: none"> ▪ GM03PNBCCH (Cheeky) ▪ GM03PNBCMD (Medium)
Business and Data Integrity Rules	For a full list of values, see the Panty Back Coverage Code List .
Attribute Length	80 Characters
Product Category	Apparel

Essential Attribute	Yes For Specific GPC bricks see Essential Attribute Matrix
----------------------------	---

3.5.145 Panty Type

General Definition	Type of panty, indicating how it fits on the body.
Also Known As	
Business Example	<ul style="list-style-type: none"> ▪ GM03PNTYHC (Hi Cut) ▪ GM03PNTYBI (Bikini)
Business and Data Integrity Rules	For a full list of values, see the Panty Type Code List .
Attribute Length	80 Characters
Product Category	Apparel
Essential Attribute	Yes For Specific GPC bricks see Essential Attribute Matrix

3.5.146 Platform Height

General Definition	The platform height is measured at the out sole from the foot bed to the sole.
Also Known As	
Business Example	
Business and Data Integrity Rules	Requires the measurement value and an accompanying unit of measure.
Attribute Length	Maximum 8 numeric (optional decimal)
Product Category	Footwear
Essential Attribute	No

3.5.147 Player Name

General Definition	The name (first and last) of the professional player applied to the product.
Also Known As	
Business Example	<ul style="list-style-type: none"> ▪ Drew Brees ▪ Ken Griffey Jr

	<ul style="list-style-type: none"> ▪ Cristiano Ronaldo ▪ Alex Morgan
Business and Data Integrity Rules	Free form text
Attribute Length	80 Characters
Product Category	Apparel, Fashion Accessories
Essential Attribute	No

3.5.148 Pocket Details

General Definition	The description of pocket details on the product.
Also Known As	
Business Example	Handbag example: Zip pocket, center zip compartment, cell phone pocket, and 2 slit pockets.
Business and Data Integrity Rules	Free form text
Attribute Length	80 Characters
Product Category	Apparel, Fashion Accessories
Essential Attribute	Yes For Specific GPC bricks see Essential Attribute Matrix

3.5.149 Primary Detail Application

General Definition	Describes the application of the primary detail on a product.
Also Known As	
Business Example	<ul style="list-style-type: none"> ▪ GM03PDAPFL (Foil) ▪ GM03PDAPGL (Glitter)
Business and Data Integrity Rules	For a full list of values, see the Primary Detail Application Code List .
Attribute Length	80 Characters
Product Category	Apparel, Fashion Accessories, Home
Essential Attribute	No

3.5.150 Primary Detail Logo

General Definition	Indicator of whether there is a logo present on the product.
Also Known As	
Business Example	
Business and Data Integrity Rules	Expressed as:

	<ul style="list-style-type: none"> ▪ Y (has a Primary Detail Logo) or ▪ N (does not have a Primary Detail Logo)
Attribute Length	1 Character
Product Category	Apparel, Fashion Accessories, Home
Essential Attribute	No

3.5.151 Primary Detail Placement

General Definition	Relative location of the primary detail application on a product.
Also Known As	
Business Example	<ul style="list-style-type: none"> ▪ GM03PDPLCL (Collar) ▪ GM03PDPLCU (Cuff)
Business and Data Integrity Rules	For a full list of values, see the Primary Detail Placement Code List .
Attribute Length	80 Characters
Product Category	Apparel, Fashion Accessories, Home
Essential Attribute	No

3.5.152 Primary Detail Size

General Definition	Relative size of the primary detail application/logo.
Also Known As	Primary Logo Size
Business Example	<ul style="list-style-type: none"> ▪ GM03PDSZLG (Large) ▪ GM03PDSZMD (Medium)
Business and Data Integrity Rules	For a full list of values, see the Primary Detail Size Code List .
Attribute Length	80 Characters
Product Category	Apparel, Fashion Accessories, Home
Essential Attribute	No

3.5.153 Primary Detail Type

General Definition	Type of primary detail on a product.
Also Known As	
Business Example	<ul style="list-style-type: none"> ▪ GM03PDTPSC (Script) ▪ GM03PDTPTE (Team)
Business and Data Integrity Rules	For a full list of values, see the Primary Detail Type Code List .
Attribute Length	80 Characters

Product Category	Apparel, Fashion Accessories, Home
Essential Attribute	No

3.5.154 Primary Motif Theme

General Definition	Motif theme of the primary detail application on the product.
Also Known As	
Business Example	<ul style="list-style-type: none"> ▪ GM03PMTTAM (Americana) ▪ GM03PMTTAN (Animal)
Business and Data Integrity Rules	For a full list of values, see the Primary Motif Theme Code List .
Attribute Length	80 Characters
Product Category	Apparel, Fashion Accessories, Home
Essential Attribute	No

3.5.155 Prop 65

General Definition	Denotes whether product is compliant with California's Proposition 65 law, which regulates substances that may cause cancer or reproductive toxicity.
Also Known As	
Business Example	<p>This product can expose you to [name of chemical], which is known to the State of California to cause birth defects or other reproductive harm.*</p> <p><i>*Note: this example is from the Office of Environmental Health Hazard Assessment in California website. GS1 US reminds users that the text of this field is determined by trading partners.</i></p>
Business and Data Integrity Rules	<p>Expressed as:</p> <ul style="list-style-type: none"> ▪ Y (contain substance(s) that require a Prop 65 warning) or ▪ N (does not contain substance(s) that require a Prop 65 warning) ▪ Additional text to communicate specifics required to meet the regulation change effective August 2018 if Y is indicated above. ▪ For further information please visit: Proposition 65 Warnings Website
Attribute Length	1 Character for Y/N indicator and 8192 characters to communicate the text of the warning.
Product Category	Common
Essential Attribute for the following GPC Brick(s):	<p>Essential for ALL GPC bricks</p> <p>For Specific GPC bricks see Essential Attribute Matrix</p>

3.5.156 Raw Materials Certifications

General Definition	Denotes if product is claiming a sustainability certification or standards for the raw materials of a product
---------------------------	---

Also Known As	
Business Example	<ul style="list-style-type: none"> • GM03RAMACV (Certified Vegan) • GM03RAMAOC (Organic Content Standard)
Business and Data Integrity Rules	For a full list of values, see the Raw Materials Certifications Code List
Business and Data Integrity Rules	<ul style="list-style-type: none"> ▪ For a full list of values, see the
Attribute Length	80 Characters
Product Category	Common
Essential Attribute	No

3.5.157

Refillable

General Definition	Indicator of whether a product or the contents of a container can be refilled.
Also Known As	
Business Example	
Business and Data Integrity Rules	Expressed as: <ul style="list-style-type: none"> ▪ Y (can be refilled) or ▪ N (cannot be refilled)
Attribute Length	1 Character
Product Category	Beauty
Essential Attribute	Yes For Specific GPC bricks see Essential Attribute Matrix

3.5.158

Re-Orderable

General Definition	Indication of whether a product can be reordered (does not imply current availability).
Also Known As	
Business Example	
Business and Data Integrity Rules	Expressed as: <ul style="list-style-type: none"> ▪ Y (can be re-ordered) or ▪ N (cannot be re-ordered)
Attribute Length	1 Character
Product Category	Common
Essential Attribute	No

3.5.159 Responsible Manufacturing

General Definition	Indicates product is responsibly manufactured with facility or process certifications
Also Known As	
Business Example	
Business and Data Integrity Rules	<ul style="list-style-type: none"> ▪ Y (is certified) ▪ N (is not certified) ▪ Additional text to communicate specifics
Attribute Length	1 Character + 8192 to communicate certification
Product Category	Common
Essential Attribute	No

3.5.160 Reversible

General Definition	Indicator that product can be worn or used with either facing outside.
Also Known As	
Business Example	
Business and Data Integrity Rules	<p>Expressed as:</p> <ul style="list-style-type: none"> ▪ Y (is reversible) or ▪ N (is not reversible)
Attribute Length	1 Character
Product Category	Apparel, Fashion Accessories, Home
Essential Attribute	<p>Yes</p> <p>For Specific GPC bricks see Essential Attribute Matrix</p>

3.5.161 Ring Type

General Definition	Indicates the shape, use, or meaning of a ring.
Also Known As	
Business Example	<ul style="list-style-type: none"> ▪ JW03RINGST (Stacked) ▪ JW03RINGTE (Toe)
Business and Data Integrity Rules	For a full list of values, see the Ring Type Code List .
Attribute Length	80 Characters
Product Category	Jewelry
Essential Attribute	<p>Yes</p> <p>For Specific GPC bricks see Essential Attribute Matrix</p>

3.5.162

Rug Type

General Definition	The usage or intended room for a particular type of rug.
Also Known As	
Business Example	<ul style="list-style-type: none"> ▪ GM03RUGTAC (Accent) ▪ GM03RUGTBA (Bath)
Business and Data Integrity Rules	For a full list of values, see the Rug Type Code List .
Attribute Length	80 Characters
Product Category	Home
Essential Attribute	No

3.5.163 Scarf Type

General Definition	A length or square of fabric typically worn around the head or neck.
Also Known As	
Business Example	<ul style="list-style-type: none"> ▪ GM03SCTYBL (Blanket) ▪ GM03SCTYBA (Bandana)
Business and Data Integrity Rules	For a full list of values, see the Scarf Type Code List .
Attribute Length	80 Characters
Product Category	Fashion Accessories
Essential Attribute	Yes For Specific GPC bricks see Essential Attribute Matrix

3.5.164 Scent Type

General Definition	Primary fragrance note or scent of the product.
Also Known As	
Business Example	<ul style="list-style-type: none"> ▪ GM03SCTPCI (Citrus) ▪ GM03SCTPEA (Earthy)
Business and Data Integrity Rules	For a full list of values, see the Scent Type Code List .
Attribute Length	80 Characters
Product Category	Beauty, Home
Essential Attribute	Yes For Specific GPC bricks see Essential Attribute Matrix

3.5.165 Seams

General Definition	Dimensional characteristic of the seams of a product.
Also Known As	
Business Example	<ul style="list-style-type: none"> ▪ IA03SEAMFL (Flat) ▪ IA03SEAMRA (Raised)
Business and Data Integrity Rules	For a full list of values, see the Seams Code List .
Attribute Length	80 Characters
Product Category	Fashion Accessories
Essential Attribute	No

3.5.166 Secondary Detail Application

General Definition	Description of the application of the secondary detail on a product.
Also Known As	
Business Example	<ul style="list-style-type: none"> ▪ GM03SDAPFL (Foil) ▪ GM03SDAPGL (Glitter)
Business and Data Integrity Rules	For a full list of values, see the Secondary Detail Application Code List .
Attribute Length	80 Characters
Product Category	Apparel, Fashion Accessories, Home
Essential Attribute	No

3.5.167 Secondary Detail Logo

General Definition	Indicator that there is a logo present on the product.
Also Known As	
Business Example	
Business and Data Integrity Rules	Expressed as: <ul style="list-style-type: none"> ▪ Y (has a Secondary Detail Logo) or ▪ N (does not have a Secondary Detail Logo)
Attribute Length	1 Character
Product Category	Apparel, Fashion Accessories, Home
Essential Attribute	No

3.5.168 Secondary Detail Placement

General Definition	Description of the relative location of the secondary detail application on a product.
Also Known As	
Business Example	<ul style="list-style-type: none"> ▪ GM03SDPLCL (Collar) ▪ GM03SDPLCU (Cuff)
Business and Data Integrity Rules	For a full list of values, see the Secondary Detail Placement Code List .
Attribute Length	80 Characters
Product Category	Apparel, Fashion Accessories, Home
Essential Attribute	No

3.5.169 Secondary Detail Size

General Definition	Relative size of the secondary detail application/logo.
Also Known As	Secondary Logo Size
Business Example	<ul style="list-style-type: none"> ▪ GM03SDSZLG (Large) ▪ GM03SDSZMD (Medium)
Business and Data Integrity Rules	For a full list of values, see the Secondary Detail Size Code List .
Attribute Length	80 Characters
Product Category	Apparel, Fashion Accessories, Home
Essential Attribute	No

3.5.170 Secondary Detail Type

General Definition	Description of the type of secondary detail on a product.
Also Known As	
Business Example	<ul style="list-style-type: none"> ▪ GM03SDTPLT (Letter) ▪ GM03SDTPMA (Mascot)
Business and Data Integrity Rules	For a full list of values, see the Secondary Detail Type Code List .
Attribute Length	80 Characters
Product Category	Apparel, Fashion Accessories, Home
Essential Attribute	No

3.5.171 Secondary Motif Theme

General Definition	Motif theme of the secondary detail application on the product.
Also Known As	
Business Example	<ul style="list-style-type: none"> ▪ GM03SMTTAM (Americana) ▪ GM03SMTTAN (Animal)
Business and Data Integrity Rules	For a full list of values, see the Secondary Motif Theme Code List .
Attribute Length	80 Characters
Product Category	Apparel, Fashion Accessories, Home
Essential Attribute	No

3.5.172 Selling Channel

General Definition	Describes if product will be sold in stores only or on-line only, or both.
Also Known As	
Business Example	<ul style="list-style-type: none"> ▪ ZZ03SELCIS (In Store Only) ▪ ZZ03SELCNR (No Restrictions)
Business and Data Integrity Rules	For a full list of values, see the Selling Channel Code List .
Attribute Length	80 Characters
Product Category	Common
Essential Attribute	No

3.5.173 Shape

General Definition	Physical form or shape of product. Specific to the item itself not the packaging.
Also Known As	
Business Example	<ul style="list-style-type: none"> ▪ GM03SHPERE (Rectangular) ▪ GM03SHPERO (Round)
Business and Data Integrity Rules	For a full list of values, see the Shape Code List .
Attribute Length	80 Characters
Product Category	Home
Essential Attribute	No

3.5.174 Shapewear Type

General Definition	Indicator of the type of shapewear and fit.
Also Known As	
Business Example	<ul style="list-style-type: none"> ▪ GM03SWRTCP (Control Panty) ▪ GM03SWRTBS (Body Shaper-to the knee)
Business and Data Integrity Rules	For a full list of values, see the Shapewear Type Code List .
Attribute Length	80 Characters
Product Category	Apparel
Essential Attribute	Yes For Specific GPC bricks see Essential Attribute Matrix

3.5.175

Shippable Package/Carton

General Definition	Indicator of whether a product can be shipped in the existing packaging without additional packaging.
Also Known As	
Business Example	Pre-packaged lamp and shade can be shipped in original carton.
Business and Data Integrity Rules	Expressed as: <ul style="list-style-type: none"> ▪ Y (can be shipped in existing packaging) or ▪ N (cannot be shipped in existing packaging)
Attribute Length	1 Character
Product Category	Common
Essential Attribute	No

3.5.176

Shoe Style

General Definition	Form, construction, usage, or special purpose of a shoe.
Also Known As	
Business Example	<ul style="list-style-type: none"> ▪ GM03SHOESL (Slide) ▪ GM03SHOEMJ (Mary Jane)
Business and Data Integrity Rules	For a full list of values, see the Shoe Style Code List . If a shoe is associated with a specific sport, identify it via attribute Sport.
Attribute Length	80 Characters
Product Category	Footwear
Essential Attribute	No

3.5.177

Shoe Type

General Definition	Description of the type of shoe.
Also Known As	
Business Example	<ul style="list-style-type: none"> ▪ GM03SETPPP (Pumps) ▪ GM03SETPSA (Sandals)
Business and Data Integrity Rules	For a full list of values, see the Shoe Type Code List .
Attribute Length	80 Characters
Product Category	Footwear
Essential Attribute	Yes For Specific GPC bricks see Essential Attribute Matrix

3.5.178

Skin Type

General Definition	Skin characteristic to which a particular beauty product is intended for use.
Also Known As	
Business Example	<ul style="list-style-type: none"> ▪ GM03SKTPDR (Dry) ▪ GM03SKTPLY (Oily)
Business and Data Integrity Rules	For a full list of values, see the Skin Type Code List .
Attribute Length	80 Characters
Product Category	Beauty
Essential Attribute	Yes For Specific GPC bricks see Essential Attribute Matrix

3.5.179

Skirt Type

General Definition	The primary silhouette and design of a skirt.
Also Known As	
Business Example	<ul style="list-style-type: none"> ▪ GM03SKRTST (Straight) ▪ GM03SKRTTI (Tiered)
Business and Data Integrity Rules	For a full list of values, see the Skirt Type Code List .
Attribute Length	80 Characters
Product Category	Apparel
Essential Attribute	Yes For Specific GPC bricks see Essential Attribute Matrix

3.5.180 Sleepwear Type

General Definition	Indicator of the type of sleepwear.
Also Known As	
Business Example	<ul style="list-style-type: none"> ▪ GM03SLPTGW (Gown) ▪ GM03SLPTRO (Robe)
Business and Data Integrity Rules	For a full list of values, see the Sleepwear Code List .
Attribute Length	80 Characters
Product Category	Apparel
Essential Attribute	Yes For Specific GPC bricks see Essential Attribute Matrix

3.5.181 Sleeve Measurement

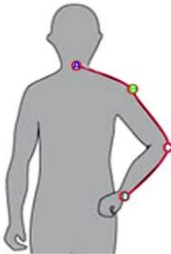
General Definition	Measurement of the garment from the base of neck, past the shoulder, around the elbow to the point at which you prefer the cuff to end. The path of the tape measure follows on the outside of the arm.
Also Known As	
Business Example	
Business and Data Integrity Rules	Requires the measurement value and an accompanying unit of measure.
Attribute Length	Maximum 20 numeric (including decimal)
Product Category	Apparel
Essential Attribute	No

3.5.182 Sleeve Type

General Definition	Style type of the sleeve portion of apparel items.
Also Known As	
Business Example	<ul style="list-style-type: none"> ▪ GM03SLVTST (Short) ▪ GM03SLVTS4 (Sleeveless)
Business and Data Integrity Rules	Please For a full list of values, see the Sleeve Type Code List .*

	<p><i>*If there is a sleeve type that does not have a code, the specifications allow for a free form text description.</i></p> <p>If there are multiple sleeve types for an item, best practice is to describe the sleeve types in the <i>Features – Benefits - Marketing Message</i> attribute.</p>
Attribute Length	Maximum 80 characters
Product Category	Apparel
Essential Attribute	Yes For Specific GPC bricks see Essential Attribute Matrix

3.5.183 Slip Split

General Definition	Indicator if the slip has split on the side seam.
Also Known As	
Business Example	
Business and Data Integrity Rules	Expressed as: <ul style="list-style-type: none"> ▪ Y (has a split) or ▪ N (does not have a split)
Attribute Length	1 Character
Product Category	Apparel
Essential Attribute	Yes For Specific GPC bricks see Essential Attribute Matrix

3.5.184 Slip Type

General Definition	Indicates the style of the intimate apparel slip.
Also Known As	
Business Example	<ul style="list-style-type: none"> ▪ GM03SLTPFL (Full) ▪ GM03SLTPHA (Half)
Business and Data Integrity Rules	For a full list of values, see the Slip Type Code List .
Attribute Length	80 Characters
Product Category	Apparel
Essential Attribute	Yes For Specific GPC bricks see Essential Attribute Matrix

3.5.185

Sole Type

General Definition	Type of material from which the sole is made.
Also Known As	Consumer Product Description
Business Example	<ul style="list-style-type: none"> ▪ GM03SOLTLS (Leather) ▪ GM03SOLTRS (Rubber)
Business and Data Integrity Rules	<p>Please For a full list of values, see the Sole Type Code List.</p> <p><i>* If there is a sole type that does not have a code, the specifications allow for a free form text description.</i></p> <p>If there are multiple sole types for an item, best practice is to describe the sole types in the <i>Features – Benefits - Marketing Message</i> attribute.</p>
Attribute Length	Maximum 80 characters
Product Category	Footwear
Essential Attribute	<p>Yes</p> <p>For Specific GPC bricks see Essential Attribute Matrix</p>

3.5.186

Social Certifications

General Definition	Specific social certifications at the product level.
Also Known As	
Business Example	<ul style="list-style-type: none"> ▪ GM03SOCEFT (Fair Trade Certified) ▪ GM03SOCDRI (Rise)
Business and Data Integrity Rules	For a full list of values, see the Social Certifications Code List .
Attribute Length	80 Characters
Product Category	Apparel, Footwear
Essential Attribute	No

3.5.187

Special Embellishment

General Definition	Description of material(s) applied to the product to embellish its appearance.
Also Known As	
Business Example	<ul style="list-style-type: none"> ▪ GM03SPEMFR (Fringe) ▪ GM03SPEMGL (Glitter)
Business and Data Integrity Rules	For a full list of values, see the Special Embellishment Code List .
Attribute Length	80 Characters
Product Category	Apparel, Footwear
Essential Attribute	No

Special Handling Code

General Definition	Coded value for special transportation handling requirements of consumer item.
Also Known As	
Business Example	<ul style="list-style-type: none"> ▪ Refrigerated (MRF) ▪ Environmental control limits (EL) ▪ Flammable (FL) ▪ Fragile (FR)
Business and Data Integrity Rules	EDI users should reference the Voluntary Interindustry Commerce Solutions® (VICS®) code list applicable to data element 152Other users may use free form.
Attribute Length	Maximum 3 characters
Product Category	Jewelry, Beauty, Home
Essential Attribute	No

3.5.188

Special Item Code

General Definition	Items not available for individual sale.
Also Known As	GWP, PWP
Business Example	<ul style="list-style-type: none"> ▪ Gift with purchase (GW) ▪ Purchase with purchase (PW) ▪ Collateral (CL)
Business and Data Integrity Rules	GW, PW, or CL (these are the only permissible values)
Attribute Length	2 characters
Product Category	Common
Essential Attribute	No

3.5.189

SPF Rating

General Definition	SPF, or Sun Protection Factor, is a measure of how well a sunscreen will protect skin from ultraviolet rays.
Also Known As	
Business Example	<ul style="list-style-type: none"> ▪ GM03SPFRRB (15) ▪ GM03SPFRRC (30)
Business and Data Integrity Rules	For a full list of values, see the SPF Rating Code List .
Attribute Length	80 Characters
Product Category	Apparel, Beauty
Essential Attribute	Yes For Specific GPC bricks see Essential Attribute Matrix

3.5.190

Sport

General Definition	Sport associated with the product.
Also Known As	
Business Example	<ul style="list-style-type: none"> ▪ ZZ03SPRTBA (Baseball) ▪ ZZ03SPRTBK (Basketball)
Business and Data Integrity Rules	For a full list of values, see the Sport Code List .
Attribute Length	80 Characters
Product Category	Apparel, Footwear, Fashion Accessories, Home
Essential Attribute	Yes For Specific GPC bricks see Essential Attribute Matrix

3.5.191 Stay Cool Handle

General Definition	Indication of whether a product is constructed with a heat resistant handle.
Also Known As	
Business Example	
Business and Data Integrity Rules	Expressed as: <ul style="list-style-type: none"> ▪ Y (has a stay cool handle) or ▪ N (does not have a stay cool handle)
Attribute Length	1 Character
Product Category	Home
Essential Attribute	No

3.5.192 Steamable

General Definition	Indication of whether a product can be steamed to remove wrinkles.
Also Known As	
Business Example	
Business and Data Integrity Rules	Expressed as: <ul style="list-style-type: none"> ▪ Y (can be steamed) or ▪ N (cannot be steamed)
Attribute Length	1 Character
Product Category	Apparel, Fashion Accessories, Home
Essential Attribute	No

3.5.193 Stone Details

General Definition	Primary gemstone associated with product.
Also Known As	
Business Example	<ul style="list-style-type: none"> ▪ 1 carat square cut genuine Emerald ▪ 3.5 mm cultured pearl, round ▪ Blue cubic zirconia briolette beads approx. 7 mm
Business and Data Integrity Rules	Should be identified with the size, shape, and whether genuine or faux. If faux, specify content (e.g., resin, glass, etc.).
Attribute Length	Maximum 80 characters
Product Category	Jewelry
Essential Attribute	No

3.5.194 Strap Placement

General Definition	Indicates where straps are located on product.
Also Known As	
Business Example	<ul style="list-style-type: none"> ▪ GM03STPLCB (Centered Back) ▪ GM03STPLRA (Racerback)
Business and Data Integrity Rules	For a full list of values, see the Strap Placement Code List .
Attribute Length	80 Characters
Product Category	Apparel, Footwear, Fashion Accessories, Home
Essential Attribute	Yes For Specific GPC bricks see Essential Attribute Matrix

3.5.195 Stretch

General Definition	Indication of whether a product is made of something capable of being made longer or wider without tearing or breaking.
Also Known As	
Business Example	
Business and Data Integrity Rules	Expressed as: <ul style="list-style-type: none"> ▪ Y (stretches) or ▪ N (does not stretch)
Attribute Length	1 Character
Product Category	<ul style="list-style-type: none"> ▪ Apparel, Fashion Accessories, Jewelry, Footwear
Essential Attribute	Yes For Specific GPC bricks see Essential Attribute Matrix

3.5.196 Supplier Suggested Retail Price

General Definition	Retail selling price suggested by the manufacturer/supplier. (This does not imply that the consumer item is marked with this price. This price may apply to one or more commercial customers.)
Also Known As	<ul style="list-style-type: none"> ▪ List price ▪ Recommended retail price ▪ MSRP
Business Example	
Business and Data Integrity Rules	Reference the GS1 US Trade Item Identification and Communication (TIIC) Guidelines for Electronic Data Interchange .
Attribute Length	Maximum 17 numeric (optional decimal)
Product Category	Common

Essential Attribute	No
----------------------------	----

3.5.197 Supplemental Circularity Certifications

General Definition	Supplemental circularity certifications that may not be directly tied to just one product but are an attribute of the product
Also Known As	
Business Example	<ul style="list-style-type: none"> GM03SUCCRR (Reusable/Recyclable Product) GM03SUCCAC (Archive Collection or Unworn Vintage)
Business and Data Integrity Rules	For a complete list of codes see the Supplemental Circularity Certifications Code List
Attribute Length	Maximum 80 characters
Product Category	Common
Essential Attribute	No

3.5.198 Supplemental Corporate/Philanthropic Certifications

General Definition	Corporate/Philanthropic certifications that may not be directly tied to just one product but are an attribute of the product
Also Known As	
Business Example	<ul style="list-style-type: none"> GM03SCOPCC (Charitable Contribution x every purchase) GM03SCOPPL (Accreditation)
Business and Data Integrity Rules	For a complete list of codes see the Supplemental Corporate/Philanthropic Certifications Code List
Attribute Length	Maximum 80 characters
Product Category	Common
Essential Attribute	No

3.5.199 Supplemental Packaging Certifications

General Definition	Supplemental packaging certifications that may not be directly tied to just one product but are an attribute of the product
Also Known As	
Business Example	<ul style="list-style-type: none"> GM03SPCERP (Reusable packaging) GM03SPCERM (Recycled packaging materials)
Business and Data Integrity Rules	For a complete list of codes see the Supplemental Packaging Certifications Code List

Attribute Length	Maximum 80 characters
Product Category	Common
Essential Attribute	No

3.5.200 Supplemental Raw Materials Certifications

General Definition	Raw materials certifications that may not be directly tied to just one product but are an attribute of the product
Also Known As	
Business Example	<ul style="list-style-type: none"> GM03SRMCUM (Non-cert Upcycled materials) GM03SRMCNV (Non-cert Vegan)
Business and Data Integrity Rules	For a complete list of codes see the Supplemental Raw Materials Certifications Code List
Attribute Length	Maximum 80 characters
Product Category	Common
Essential Attribute	No

3.5.201 Supplemental Traceability Programs

General Definition	Additional traceability programs that can be applied to a product or grouping of products
Also Known As	
Business Example	<ul style="list-style-type: none"> GM03SUTRDP (Digital Passport) GM03SUTRTP (Traceability Program)
Business and Data Integrity Rules	For a complete list of codes see the Supplemental Traceability Programs Code List
Attribute Length	Maximum 80 characters
Product Category	Common
Essential Attribute	No

3.5.202 Supplier Wholesale Price

General Definition	Unit price of the trade item as defined by the supplier. This price may apply to one or more commercial customers.
Also Known As	Unit cost
Business Example	
Business and Data Integrity Rules	
Attribute Length	Maximum 17 numeric (optional decimal)

Product Category	Common
Essential Attribute	No

3.5.203

Supply Type

General Definition	Describes when and if product can be ordered and/or replenished.
Also Known As	
Business Example	<ul style="list-style-type: none"> ▪ Evergreen (Core) - Vendor can fill order all year anytime - appx 95% in season or greater fill rate ▪ Made to Stock - Vendor plans to stock item but Retailers can expect a less that 95% in season fill rate ▪ Made to Order (Fashion/Seasonal) - No in season replenishment orders will be filled. Pre-order only ▪ Perennial - Seasonally available. The product comes back year after year ▪ Seasonal with Limited Replenishment- Limited in season replenishment, subject to availability
Business and Data Integrity Rules	For a full list of values, see the Supply Type Code List . Examples of codes: <ul style="list-style-type: none"> ▪ ZZ03SUTYMT (Made to Order) ▪ ZZ03SUTYMS (Made to Stock)
Attribute Length	80 Characters
Product Category	Common
Essential Attribute	No

3.5.204

Support Level

General Definition	Indicates the level of support the material of the item supplies to the wearer.
Also Known As	
Business Example	<ul style="list-style-type: none"> ▪ GM03SULVFA (Full Support) ▪ GM03SULVMA (Maximum Support)
Business and Data Integrity Rules	For a full list of values, see the Support Level Code List .
Attribute Length	80 Characters
Product Category	Apparel
Essential Attribute	Yes For Specific GPC bricks see Essential Attribute Matrix

3.5.205

Sustainable Materials

General Definition	Indicates that product is made of at least 50% sustainable materials
Also Known As	

Business Example	<ul style="list-style-type: none"> ▪ Y (Product contains 50% sustainable materials) ▪ N (Product does not contain 50% sustainable materials) ▪ Text field to share certifications/or other details to describe how product contains sustainable materials
Business and Data Integrity Rules	
Attribute Length	1 Character for Y/N indicator and 8192 characters for details of the sustainability
Product Category	Common
Essential Attribute	No

3.5.206 Sustainable Packaging

General Definition	<ul style="list-style-type: none"> ▪ Packaging must be made from at least 50% recycled content or must be refillable or recyclable
Also Known As	
Business Example	<ul style="list-style-type: none"> ▪ Y (Product contains 50% recycled packaging materials) ▪ N (Product does not contain 50% recycled packaging materials) ▪ Text field to share certifications/or other details to describe how product contains sustainable packaging materials
Business and Data Integrity Rules	
Attribute Length	1 Character for Y/N indicator and 8192 characters for details of the sustainability
Product Category	Common
Essential Attribute	No

3.5.207 Sweater/Pullover Type

General Definition	Design characteristics of a sweater or pullover.
Also Known As	
Business Example	<ul style="list-style-type: none"> ▪ GM03SWPUTA (Tank) ▪ GM03SWPUTS (T-Shirt)
Business and Data Integrity Rules	For a full list of values, see the Sweater/Pullover Type Code List .
Attribute Length	80 Characters
Product Category	Apparel
Essential Attribute	Yes For Specific GPC bricks see Essential Attribute Matrix

3.5.208 Swim Bottom Type

General Definition	Any product that may be used or described for swimming and covers the lower half of the body
Also Known As	
Business Example	<ul style="list-style-type: none"> ▪ GM03SWBTBA (Banded) ▪ GM03SWBTBO (Boardshort)
Business and Data Integrity Rules	For a full list of values, see the Swim Bottom Code List .
Attribute Length	80 Characters
Product Category	Apparel
Essential Attribute	Yes For Specific GPC bricks see Essential Attribute Matrix

3.5.209 Swim Cover-up Type

General Definition	Any product that may be described/observed as a garment worn over swimwear.
Also Known As	
Business Example	<ul style="list-style-type: none"> ▪ GM03SWCTBS (Beach Shirt) ▪ GM03SWCTBO (Bottom)
Business and Data Integrity Rules	For a full list of values, see the Swim Cover-Up Type Code List .
Attribute Length	80 Characters
Product Category	Apparel
Essential Attribute	Yes For Specific GPC bricks see Essential Attribute Matrix

3.5.210 Swim One-piece Type

General Definition	Any product that may be described/observed as a garment worn for swimming that covers the upper and lower half of the body as one piece.
Also Known As	
Business Example	<ul style="list-style-type: none"> ▪ GM03SWOTBA (Bandeau) ▪ GM03SWOTHA (Halter)
Business and Data Integrity Rules	For a full list of values, see the Swim One-Piece Type Code List .
Attribute Length	80 Characters
Product Category	Apparel
Essential Attribute	Yes For Specific GPC bricks see Essential Attribute Matrix

3.5.211 Swim Top Type

General Definition	Any product that may be described/observed as a garment worn for swimming that covers the top half of the body.
Also Known As	
Business Example	<ul style="list-style-type: none"> ▪ GM03SWTTBA (Bandeau) ▪ GM03SWTTBN (Bandini)
Business and Data Integrity Rules	For a full list of values, see the Swim Top Type Code List .
Attribute Length	80 Characters
Product Category	Apparel
Essential Attribute	Yes For Specific GPC bricks see Essential Attribute Matrix

3.5.212 Tableware Type

General Definition	Type of tabletop products.
Also Known As	
Business Example	<ul style="list-style-type: none"> ▪ GM03TBLTDI (Dinnerware) ▪ GM03TBLTFL (Flatware)
Business and Data Integrity Rules	For a full list of values, see the Tableware Type Code List
Attribute Length	80 Characters
Product Category	Home
Essential Attribute	No

3.5.213 Tag

General Definition	Indicator if there is a physical tag present.
Also Known As	
Business Example	
Business and Data Integrity Rules	Expressed as: <ul style="list-style-type: none"> ▪ Y (has a tag) or ▪ N (does not have physical tag)
Attribute Length	1 Character
Product Category	Apparel, Fashion Accessories
Essential Attribute	No

3.5.214 Team Name

General Definition	Professional, collegiate, or other sports team name associated with a product.
Also Known As	
Business Examples	<ul style="list-style-type: none"> ▪ New York Rangers ▪ Manchester United ▪ Dallas Cowboys ▪ LSU Tigers
Business and Data Integrity Rules	
Attribute Length	Maximum 80 characters
Product Category	Apparel, Footwear, Jewelry, Fashion Accessories, Home
Essential Attribute	No

3.5.215 Third Detail Application

General Definition	Description of the application of the third detail on a product.
Also Known As	
Business Example	<ul style="list-style-type: none"> ▪ GM03TDAPFL (Foil) ▪ GM03TDAPGL (Glitter)
Business and Data Integrity Rules	For a full list of values, see the Third Detail Application Code Type .
Attribute Length	80 Characters
Product Category	Apparel, Fashion Accessories, Home
Essential Attribute	No

3.5.216 Third Detail Logo

General Definition	Indicator of whether there is a logo present on the product.
Also Known As	
Business Example	
Business and Data Integrity Rules	Expressed as: <ul style="list-style-type: none"> ▪ Y (has a Third Detail Logo) or ▪ N (does not have a Third Detail Logo)
Attribute Length	1 Character
Product Category	Apparel, Fashion Accessories, Home
Essential Attribute	No

3.5.217 Third Detail Placement

General Definition	Describes the relative location of the third detail application on a product.
Also Known As	
Business Example	<ul style="list-style-type: none"> ▪ GM03TDPLCL (Collar) ▪ GM03TDPLCU (Cuff)
Business and Data Integrity Rules	For a full list of values, see the Third Detail Placement Code List .
Attribute Length	80 Characters
Product Category	Apparel, Fashion Accessories, Home
Essential Attribute	No

3.5.218 Third Detail Size

General Definition	Relative size of the third detail application/logo.
Also Known As	Third Logo Size
Business Example	<ul style="list-style-type: none"> ▪ GM03TDSZLG (Large) ▪ GM03TDSZMD (Medium)
Business and Data Integrity Rules	For a full list of values, see the Third Detail Size Code List .
Attribute Length	80 Characters
Product Category	Apparel, Fashion Accessories, Home
Essential Attribute	No

3.5.219 Third Detail Type

General Definition	Description of the type of third detail on a product.
Also Known As	
Business Example	<ul style="list-style-type: none"> ▪ GM03TDTPMA (Mascot) ▪ GM03TDTPNU (Number)
Business and Data Integrity Rules	For a full list of values, see the Third Detail Type Code List .
Attribute Length	80 Characters
Product Category	Apparel, Fashion Accessories, Home
Essential Attribute	No





3.5.220

Third Motif Theme

General Definition	Motif theme of the third detail application on the product.
Also Known As	
Business Example	<ul style="list-style-type: none"> ▪ GM03TMTTAM (Americana) ▪ GM03TMTTAN (Animal)
Business and Data Integrity Rules	For a full list of values, see the Third Motif Theme Code List .
Attribute Length	80 Characters
Product Category	Apparel, Fashion Accessories, Home
Essential Attribute	No



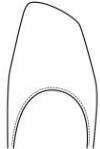

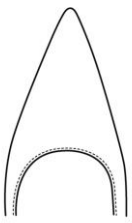
3.5.221

Toe Shape

General Definition	Shape of the toe of a shoe.
Also Known As	
Business Example	<ul style="list-style-type: none"> ■ GM03TOESPY (Pointy) ■ GM03TOESRD (Round) <div style="display: flex; justify-content: space-around; align-items: flex-start;"> <div style="text-align: center;"> <p>ALMOND</p>  </div> <div style="text-align: center;"> <p>ROUND</p>  </div> <div style="text-align: center;"> <p>OBLIQUE</p>  </div> <div style="text-align: center;"> <p>SQUARE TOE</p>  </div> </div> <div style="text-align: center; margin-top: 20px;"> <p>POINTED</p>  </div>
Business and Data Integrity Rules	For a full list of values, see the Toe Shape Code List
Attribute Length	80 Characters
Product Category	Footwear
Essential Attribute	Yes For Specific GPC bricks see Essential Attribute Matrix

3.5.222

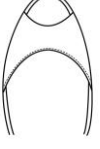
Toe Style

General Definition	Style of the toe of a shoe.
Also Known As	
Business Example	<ul style="list-style-type: none"> ■ GM03TOESPY ■ GM03TOESRD <div style="display: flex; justify-content: space-around; align-items: flex-end; margin-top: 10px;"> <div style="text-align: center;"> <p>APRON TOE</p>  </div> <div style="text-align: center;"> <p>CAP TOE</p>  </div> <div style="text-align: center;"> <p>PEEP</p>  </div> <div style="text-align: center;"> <p>SPLIT TOE</p>  </div> </div>
Business and Data Integrity Rules	For a full list of values, see the Toe Style Code List .
Attribute Length	80 Characters
Product Category	Footwear
Essential Attribute	Yes For Specific GPC bricks see Essential Attribute Matrix

3.5.223

Towel Type

General Definition	Type of towel based on intended use.
Also Known As	
Business Example	<ul style="list-style-type: none"> ■ GM03TOWLBE (Beach) ■ GM03TOWLHA (Hand)
Business and Data Integrity Rules	For a full list of values, see the Towel Type Code List .
Attribute Length	80 Characters
Product Category	Home
Essential Attribute	No

3.5.224 Vendor Collection Name

General Definition	Name the vendor applies to a collection or grouping of consumer products.
Also Known As	
Business Example	<ul style="list-style-type: none"> ▪ Island Breeze ▪ Monterey Bay
Business and Data Integrity Rules	
Attribute Length	Maximum 80 characters
Product Category	Common
Essential Attribute	No

3.5.225 Waist Rise

General Definition	Measurement of the garment from the bottom of the crotch seam to the top of the waistband.
Also Known As	
Business Example	<ul style="list-style-type: none"> ▪ GM03WSDRLW (Low) ▪ GM03WSDRMI (Mid)
Business and Data Integrity Rules	For a full list of values, see the Waist Rise Code List .
Attribute Length	80 Characters
Product Category	Apparel
Essential Attribute	Yes For Specific GPC bricks see Essential Attribute Matrix

3.5.226 Waistband Type

General Definition	The construction of the waistband of a particular product.
Also Known As	
Business Example	<ul style="list-style-type: none"> ▪ GM03WBTPBH (Belt Hook) ▪ GM03WBTPDS (Drawstring)
Business and Data Integrity Rules	For a full list of values, see the Waistband Type Code List .
Attribute Length	80 Characters
Product Category	Apparel
Essential Attribute	Yes For Specific GPC bricks see Essential Attribute Matrix

3.5.227 Warranty Description

General Definition	The consumer warranty description which the retailer keeps on file in the event a consumer has a claim against the warranty.
Also Known As	
Business Example	3-year warranty on materials and workmanship
Business and Data Integrity Rules	Matches the warranty claim on the product, packaging, or brand owner’s website.
Attribute Length	Maximum 4096 characters
Product Category	Jewelry, Home
Essential Attribute	No

3.5.228 Watch Band Width

General Definition	Measurement between the two connectors (lugs) where band connects to watch.
Also Known As	Lug width
Business Example	
Business and Data Integrity Rules	
Attribute Length	Maximum 8 numeric (optional decimal)
Product Category	Jewelry
Essential Attribute	Yes For Specific GPC bricks see Essential Attribute Matrix

3.5.229 Watch Case Shape

General Definition	The primary shape of the watch case.
Also Known As	
Business Example	<ul style="list-style-type: none"> ▪ JW03WACSRN (Round) ▪ JW03WACSSQ (Square)
Business and Data Integrity Rules	For a full list of values, see the Watch Case Shape Code List .
Attribute Length	80 Characters

Product Category	Jewelry
Essential Attribute	Yes For Specific GPC bricks see Essential Attribute Matrix

3.5.230 Watch Case Size

General Definition	Measurement of the face of the watch.
Also Known As	
Business Example	
Business and Data Integrity Rules	This measurement can be either the diameter if the face is round, or the width and height if the face is rectangular or square.
Attribute Length	Maximum 8 numeric (optional decimal)
Product Category	Jewelry
Essential Attribute	Yes For Specific GPC bricks see Essential Attribute Matrix

3.5.231 Water Repellant

General Definition	Indication of whether product has a finish that resists absorption or penetration of water.
Also Known As	
Business Example	<ul style="list-style-type: none"> ■ ZZ03WATRPF (Waterproof) ■ ZZ03WATRRE (Water resistant)
Business and Data Integrity Rules	For a full list of values, see the Water Repellant Code List .
Attribute Length	80 Characters
Product Category	Common
Essential Attribute	Yes For Specific GPC bricks see Essential Attribute Matrix

3.5.232

Wrinkle Resistant

General Definition	Indication of whether the product is treated to be wrinkle resistant.
Also Known As	
Business Example	
Business and Data Integrity Rules	Expressed as: <ul style="list-style-type: none"> ▪ Y (is wrinkle resistant) or ▪ N (is not wrinkle resistant)
Attribute Length	1 Character
Product Category	Apparel, Home
Essential Attribute	Yes For Specific GPC bricks see Essential Attribute Matrix

3.6 GS1 Extended Attribute Code Lists

3.6.1 [Adjustable Strap Code List](#)

Code List Values for Adjustable Strap			
Fully Adjustable	GM03ADSTFA	Partially Adjustable	GM03ADSTPA
Non-Adjustable	GM03ADSTNA	Other	GM03ADST99

3.6.2 [Advertised Origin Code List](#)

Code List Values for Advertised Origin	
Imported	GM03ADVOIM
Made in Canada	GM03ADVOMC
Made in U.S.A.	GM03ADVOMU
Made in U.S.A. and Imported	GM03ADVOUI
Made in U.S.A. or Imported	GM03ADVOUO
Made in another country*	GM04ADVO99

* Requires use of PID05

3.6.3 Bag Type Code List

Code List Values for Bag Type			
Backpack	GM03BGSTBA	Saddle Bag	GM03BGSTSB
Bucket Bag	GM03BGSTBB	Satchel	GM03BGSTSA
Clutch	GM03BGSTCL	Shopper	GM03BGSTSJ
Crossbody	GM03BGSTCR	Shoulder Bag	GM03BGSTSH
Diaper Bag	GM03BGSTDB	Tote	GM03BGSTTT
Duffel	GM03BGSTDU	Waist Bag	GM03BGSTWB
Hobo	GM03BGSTHB	Wristlet	GM03BGSTWR
Messenger Bag	GM03BGSTMB	Other	GM04BGST99
Pouch	GM03BGSTPH		

3.6.4 Band Type Code List

Code List Values for Band Type	
Bangle	JW03WBNDDBA
Bracelet	JW03WBNDDBR
Cuff	JW03WBNDDCU
NATO Strap	JW03WBNDDNA
Strap	JW03WBNDST
Other	JW04WBND99

3.6.5 Beauty Area of Use Code Lis

Code List Values for Beauty Area of Use			
Body	GM03BAOUBD	Lip	GM03BAOULP
Brow	GM03BAOUBR	Multi	GM03BAOUMU
Cheek	GM03BAOUCH	Nail	GM03BAOUNA
Eye	GM03BAOUEY	Neck	GM03BAOUNE
Face	GM03BAOUFA	Pedi	GM03BAOUPE
Hair	GM03BAOUHR	Teeth	GM03BAOUTE
Hand	GM03BAOUHN	Other	GM04BAOU99
Lash	GM03BAOULA		

3.6.6 Beauty Treatment Specialty Code List

Code List Values for Beauty Treatment Specialty			
After Sun	GM03BTSPAS	Redness/Rosacea	GM03BTSPRR
Anti-Acne	GM03BTSPAA	Repair	GM03BTSPRE
Cellulite	GM03BTSPCE	Self Tan	GM03BTSPST
Conditioning	GM03BTSPCD	Shaving	GM03BTSPSH
Day	GM03BTSPDA	Uneven Skin Tone	GM03BTSPUN
Firming/Lifting	GM03BTSPFL	Wrinkles	GM03BTSPWR
Moisturizing	GM03BTSPMS	Heat and Sun Protection	GM03BTSPHS
Anti-Frizz	GM03BTSPAF	Oil Control	GM03BTSPOC
Clarifying	GM03BTSPCL	Straightening	GM03BTSPSG
Color Protection	GM03BTSPCP	Texturizing	GM03BTSPTX
Curl Defining	GM03BTSPCG	Thinning and Hair Loss	GM03BTSPTH
Damage Repair	GM03BTSPDR	Volumizing	GM03BTSPVO
Dry Scalp	GM03BTSPDS	Other	GM04BTSP99
Dullness	GM03BTSPDU		
Night	GM03BTSPNI		

3.6.7 Beauty Type Code List



Code List Values for Beauty Type			
After Shave	GM03BATYAS	Mask	GM03BATYMK
Base Coat	GM03BATYBC	Make-up Brush	GM03BATYMB
BB / CC	GM03BATYBB	Make-up Brush Cleaner	GM03BATYMC
Blush/Bronzer	GM03BATYBL	Mirror	GM03BATYMI
Blade Sharpener	GM03BATYBR	Moisturizer	GM03BATYMO
Beauty Spray	GM03BATYBS	Multi-use Palette	GM03BATYMP
Cleansing Brush	GM03BATYCB	Make-up Remover	GM03BATYMR
Curling Iron	GM03BATYCI	Manicure Set	GM03BATYMS
Cleanser	GM03BATYCL	Nail Polish	GM03BATYNP
Conditioner	GM03BATYCN	Perfume/Cologne	GM03BATYPC
Concealer	GM03BATYCO	Plumper	GM03BATYPL
Diffuser	GM03BATYDI	Powder	GM03BATYPO
Curler	GM03BATYEC	Primer	GM03BATYPR
Eyebrow Enhancer	GM03BATYEE	Pencil Sharpener	GM03BATYPS
Electric Razor	GM03BATYER	Pre-Shave	GM03BATYPE
Eye Shadow	GM03BATYES	Razor	GM03BATYRA
Exfoliator	GM03BATYEX	Razor Blade	GM03BATYRB
False Eyelashes	GM03BATYFE	Shave Brush	GM03BATYSB
Flat Iron	GM03BATYFI	Shaving Cream	GM03BATYSC
Foundation	GM03BATYFO	Sun Care	GM03BATYSU
Gloss	GM03BATYGL	Serum	GM03BATYSE
Groomer	GM03BATYGR	Shampoo	GM03BATYSH
Hair Brush	GM03BATYHB	Shave Bowl	GM03BATYSL
Hair Dryer	GM03BATYHD	Sponge	GM03BATYSP
Hair Spray	GM03BATYHS	Shave Set	GM03BATYSS
Hair Trimmer	GM03BATYHT	Styling Product	GM03BATYST
Laquer	GM03BATYLA	Top Coat	GM03BATYTC
Lip Balm	GM03BATYLB	Toner/Clarifyer	GM03BATYTO
Lip Liner	GM03BATYLI	Tinted Moisturizer	GM03BATYTM
Lip Stick	GM03BATYLS	Tweezer	GM03BATYTW
Mascara	GM03BATYMA	Other	GM04BATY99

3.6.8 *Bedding Size Code List*

Code List Values for Bedding Size			
Baby/Swaddle	GM03BDSZBS	Jumbo	GM03BDSZJU
Body	GM03BDSZBD	King	GM03BDSZKI
California King	GM03BDSZCK	Queen	GM03BDSZQU
Contour	GM03BDSZCN	Standard	GM03BDSZST
Crib	GM03BDSZCR	Throw	GM03BDSZTH
Euro	GM03BDSZEU	Twin	GM03BDSZTW
Full/Queen	GM03BDSZFQ	Twin Extra Long	GM03BDSZTX
Full/Standard	GM03BDSZFS	Other	GM04BDSZ99

3.6.9 Bedding Type Code List

Code List Values for Bedding Type			
Bedsread	GM03BEDTBS	Pillowcase	GM03BEDTPC
Comforter	GM03BEDTCM	Sham	GM03BEDTSH
Duvet Cover	GM03BEDTDC	Sheet Set	GM03BEDTSS
Fitted Sheet	GM03BEDTFI	Other	GM04BEDT99
Flat Sheet	GM03BEDTFL		

3.6.10 Belt Type Code List

Code List Values for Bill Logo Application			
Braided	GM03BETYBR	Ratchet	GM03BETYRA
Chain	GM03BETYCH	Sash	GM03BETYSA
Cinch	GM03BETYCI	Strap	GM03BETYST
Cummerbund	GM03BETYCU	Stretch	GM03BETYSH
Hip	GM03BETYHI	Suspenders	GM03BETYSU
Lace-up	GM03BETYLU	Yoke	GM03BETYYO
Military	GM03BETYMI	Other	GM04BETY99
Obi	GM03BETYOB		

3.6.11 Bill Logo Application Code List

Code List Values for Bill Logo Application			
Fabric Applique	GM03BILLFA	Screen Print	GM03BILLSP
Raised Embroidery	GM03BILLRE	Other	GM04BILL99

3.6.12 Bill Type Code List

Code List Values for Bill Type			
Flip Color	GM03BILTFC	Print	GM03BILTFR
Flip Up	GM03BILTFU	Sandwich	GM03BILTSA
Normal	GM03BILTNL	Short	GM03BILTSH

3.6.13 Boot Shaft Type Code List

Code List Values for Boot Shaft Type			
--------------------------------------	--	--	--

Low shaft/Ankle	GM03BTSTAN	Over Knee XX	GM03BTSTOK
Knee High/Tall	GM03BTSTKH	Tall	GM03BTSTTL
Low Shaft	GM03BTSTLS	Other	GM0BTST99
Mid Calf	GM03BTSTMI		

3.6.14 Bra Band Type Code List

Code List Values for Bra Band Type			
Smoothing Back	GM03BRBNSB	Toed In	GM03BRBNTI
Smoothing Side	GM03BRBNSS	U Back/Leotard Back	GM03BRBNUB
Straight Back	GM03BRBNST	Other	GM03BRBN99
T-back	GM03BRBNTB		

3.6.15 Bra Bust Type Code List

Code List Values for Bra Bust Type			
Average	GM03BRBTAV	Shallow	GM03BRBTSH
Full Figured	GM03BRBTFF	Other	GM03BRBT99

3.6.16 Bra Cup Coverage Code List

Code List Values for Bra Cup Coverage			
3/4	GM03BRCC34	Plunge	GM03BRCCPL
Balconette	GM03BRCCBA	Triangle	GM03BRCCTR
Demi	GM03BRCCDE	Other	GM03BRCC99
Full	GM03BRCCFL		

3.6.17 Bra Cup Type Code List

Code List Values for Bra Cup Type			
Contour (padded cup)	GM03BRCTCO	Molded (no padded cup)	GM03BRCTMO
Cut & Sewn	GM03BRCTCU	Push-Up	GM03BRCTPU
Gel Padding	GM03BRCTGP	Seamless	GM03BRCTSE
Liquid Padding	GM03BRCTLP	Spacer	GM03BRCTSP
Memory Foam	GM03BRCTMF	Other	GM03BRCT99

3.6.18 Bra Impact Level Code List

Code List Values for Bra Impact Level			
High	GM03BRILHI	Medium	GM03BRILMD
High +	GM03BRILHP	Other	GM03BRIL99
Low	GM03BRILLO		

3.6.19 Bra Padding Code List

Code List Values for Bra Padding			
Integrated Padding	GM03BRPDIP	Other	GM03BRPD99
Removable Padding/Pocketed	GM03BRPDRP		

3.6.20 Bra Specialty Type Code List

Code List Values for Bra Specialty Type			
Backless	GM03BRSTBL	Post-Surgical	GM03BRSTPS
Mastectomy	GM03BRSTMA	Sleep	GM03BRSTSL
Maternity/Nursing	GM03BRSTMT	Other	GM03BRST99

3.6.21 Bra Type Code List

Code List Values for Bra Type			
Bandeau	GM03BRTYBN	Minimizer	GM03BRTYMN
Bralette	GM03BRTYBR	Sport	GM03BRTYSP
Bustier	GM03BRTYBU	Standard/Conventional	GM03BRTYSC
Convertible	GM03BRTYCN	Strapless	GM03BRTYST
Corset	GM03BRTYCO	Training	GM03BRTYTR
Halter	GM03BRTYHA	T-Shirt	GM03BRTYTS
Long Line	GM03BRTYLL	Other	GM03BRTY99

3.6.22 Bracelet Type Code List

Code List Values for Bracelet Type			
Adjustable	JW03BRTTAD	Hinge	JW03BRTTHN
Bangle	JW03BRTTBA	Line	JW03BRTTLI
Bracelet Set	JW03BRTTBS	Open Cuff	JW03BRTTOC
Chain	JW03BRTTCH	Stretch	JW03BRTTST
Charm	JW03BRTTCM	Wrap	JW03BRTTWR
Coil	JW03BRTTCL	Other	JW04BRTT99
Cuff	JW03BRTTCF		

3.6.23 Care Instructions Code List

Code List Values for Care Instructions Code			
Dishwasher Safe	GM03CAINDS	Machine Wash Hot	GM03CAINMH
Do Not Iron	GM03CAINDN	Machine Wash Line Dry	GM03CAINML
Dry Clean	GM03CAINDC	Machine Wash Tumble Dry	GM03CAINMT
Hand Wash	GM03CAINHW	Machine Wash Warm	GM03CAINMW
Leather Method Dry Cleaning	GM03CAINLM	Spot Clean	GM03CAINSC
Machine Wash Cold	GM03CAINMC	Wash Separately	GM03CAINWS
Machine Wash Dry Flat	GM03CAINMD	Other	GM04CAIN99

3.6.24 Chemical Certifications Code List

Code List Values for Chemical Certifications			
bluesign	GM03CHCEBL	ZDHC MRSL Certifications	GM03CHCEZD
OEKO-TEX Standard 100 Certified	GM03CHCEOT	Other	GM04CHCE99
OEKO-TEX Standard Made in Green	GM03CHCEOG		

3.6.25 Closure Code List

Code List Values for Closure			
Adjustable/Pull	GM03CLOSAP	Lace-up Front	GM03CLOSLF
Back	GM03CLOSBC	Latch	GM03CLOSLA
Back Button/Zip	GM03CLOSBB	Leverback	GM03CLOSLB

Code List Values for Closure			
Back Hook/Zip	GM03CLOSBH	Lift-Lock	GM03CLOSLL
Barrel	GM03CLOSBA	Link/Clasp	GM03CLOSLC
Box Tab Insert	GM03CLOSBT	Lobster Claw	GM03CLOSLW
Buckle	GM03CLOSBU	Magnetic	GM03CLOSMG
Button	GM03CLOSBN	Pierced Post	GM03CLOSPP
Button Back	GM03CLOSBK	Push-Lock	GM03CLOSPL
Button Front	GM03CLOSBF	Side Button/Zip	GM03CLOSSB
Button Front Partial	GM03CLOSBP	Side Hook/Zip	GM03CLOSSZ
Button Shoulder	GM03CLOSBS	Snap	GM03CLOSSN
Clasp	GM03CLOSCL	Snap Back	GM03CLOSSM
Click Top	GM03CLOSCT	Snap Front	GM03CLOSSF
Clip On	GM03CLOSCO	Snap Front Partial	GM03CLOSS2
Drawstring	GM03CLOSDS	Snap Legs	GM03CLOSSE
Drawstring Front	GM03CLOSDF	Snap Shoulder	GM03CLOSSS
Drawstring Elastic	GM03CLOSDE	Snap Post	GM03CLOSSA
D Ring	GM03CLOSDR	String	GM03CLOSSR
Elastic Lace with Toggle	GM03CLOSET	Swivel	GM03CLOSSW
O Ring	GM03CLOSDO	Tab	GM03CLOSTB
Fishhook	GM03CLOSFS	Tie	GM03CLOSTI
Flap	GM03CLOSFP	Tie Back/Halter	GM03CLOSTH
Foldover	GM03CLOSFO	Tie Front	GM03CLOSTF
French Wire	GM03CLOSFW	Tie Side	GM03CLOSTS
Frog/Button Loop	GM03CLOSFA	Toggle	GM03CLOSTO
Front Button/Zip	GM03CLOSFZ	Toggle Front	GM03CLOSTN
Front Hook/Zip	GM03CLOSFH	Top Zip	GM03CLOSTZ
Hidden Button Front	GM03CLOSHB	Tunnel Side Tie	GM03CLOSTQ
Hidden Snap Front	GM03CLOSHS	Turn Lock	GM03CLOSTL
Hidden Zip Front	GM03CLOSHZ	Wrap	GM03CLOSZR
Hinged	GM03CLOSHI	Zipper	GM03CLOSZI
Hinged/Foldover	GM03CLOSHE	Zipper Back	GM03CLOSZB
Hook	GM03CLOSHO	Zipper Back Partial	GM03CLOSZP

Code List Values for Closure			
Hook and Loop	GM03CLOSHL	Zipper Front	GM03CLOSZF
Hook-and-eye Front	GM03CLOSHC	Zipper Front Partial	GM03CLOSZR
Hook-and-eye Back	GM03CLOSHD	Zipper Side	GM03CLOSZS
Keyhole Button	GM03CLOSKB	Zipper Around	GM03CLOSZA
Kiss-Lock	GM03CLOSKL	1/4 Zip	GM03CLOSZQ
Knot	GM03CLOSKN	1/2 Zip	GM03CLOSZH
Lace Up	GM03CLOSLU	Other Closure*	GM04CLOS99

* Requires use of PID05

3.6.26 Coat/Jacket Type Code List

Code List Values for Coat/Jacket Type			
Anorak	GM03COATAN	Pant/Car Coat	GM03COATPC
Barn Coat	GM03COATBC	Parka	GM03COATPA
Blazer	GM03COATBA	Peacoat	GM03COATPE
Bolero	GM03COATBL	Poncho	GM03COATPN
Bomber	GM03COATBM	Puffer	GM03COATPU
Cape	GM03COATCP	Sportscoat	GM03COATSP
Cardigan	GM03COATCA	Swing Coat	GM03COATSC
Field Jacket	GM03COATFK	Trench	GM03COATTR
Fit & Flare	GM03COATFF	Trucker	GM03COATTU
Hoodie	GM03COATHO	Vest	GM03COATVE
Military	GM03COATMI	Windbreaker	GM03COATWI
Motorcycle	GM03COATMT	Wrap	GM03COATWR
Overcoat	GM03COATOC	Other	GM04COAT99

3.6.27 Collar/Neck Type Code List

Code List Values for Collar/Neck Type			
Ballet	GM03CLNTBL	Plunge	GM03CLNTPJ
Banded	GM03CLNTBC	Point	GM03CLNTPO
Boat or Bateau	GM03CLNTBE	Polo	GM03CLNTPU
Button-Down	GM03CLNTBD	Portrait Collar	GM03CLNTPR

Code List Values for Collar/Neck Type			
Cowl	GM03CLNTCW	¼-Zip Mock	GM03CLNTQZ
Crew	GM03CLNTRC	Racer Back	GM03CLNTRB
Drape	GM03CLNTDP	Rolled	GM03CLNTRD
Funnel	GM03CLNTFU	Round	GM03CLNTRU
Halter	GM03CLNTHA	Sailor	GM03CLNTSD
Henley	GM03CLNTHN	Scoop	GM03CLNTSC
Henley Faux	GM03CLNTHF	Shawl	GM03CLNTSH
Henley Functional	GM03CLNTHU	Slider Halter	GM03CLNTSL
Jewel	GM03CLNTJE	Spread	GM03CLNTSO
Johnny	GM03CLNTJO	Square	GM03CLNTSQ
Keyhole	GM03CLNTKE	Stand	GM03CLNTSV
Mandarin	GM03CLNTMB	Surplice	GM03CLNTSU
Marilyn	GM03CLNTMI	Sweetheart	GM03CLNTSX
Mockneck	GM03CLNTMO	Tab	GM03CLNTTA
Necklace	GM03CLNTNE	Tie	GM03CLNTTI
Notch	GM03CLNTNO	Turtle	GM03CLNTTU
Off the Shoulder	GM03CLNTOR	V-Neck	GM03CLNTVN
One Shoulder	GM03CLNTOS	Wing	GM03CLNTWI
Ottoman	GM03CLNTOT	Y-Neck	GM03CLNTYN
Peter Pan	GM03CLNTPA	Other Collar*	GM04CLNT99
Platter	GM03CLNTPE		

* Requires use of PID05

3.6.28 Conference Code List

Code List Values for Conference			
ACC	ZZ03CONFAC	National League	ZZ03CONFNL
AFC	ZZ03CONFAC	NFC	ZZ03CONFNF
American League	ZZ03CONFAL	Pac 12	ZZ03CONFPA
Big 10	ZZ03CONFBT	SEC	ZZ03CONFSE
Big 12	ZZ03CONFBW	The American	ZZ03CONFAM
Eastern	ZZ03CONFEA	Western	ZZ03CONFWE
Independents	ZZ03CONFIN	Other	ZZ04CONF99

3.6.29 Consumer Life Stage Code List

Code List Values for Consumer Life Stage			
Adult	GM03CNLSAD	Teen	GM03CNLSTE
All Ages	GM03CNLSAG	Toddler	GM03CNLSTD
Baby/Infant	GM03CNLSBI	Unclassified	GM03CNLSYA
Child	GM03CNLSCH	Unidentified	GM03CNLSUC
Child 1-2 Years	GM03CNLSCT	Young Adult	GM03CNLSYA
Child 2 Years Onwards	GM03CNLSCW	Other	GM04CNLS99
Premie	GM03CNLSPR		

3.6.30 Control Level Code List

Code List Values for Control Level			
Extra Firm	GM03CONLEF	Medium	GM03CONLMD
Firm	GM03CONLFR	Other	GM03CONL99
Light	GM03CONLLT		

3.6.31 Cookware Type Code List

Code List Values for Cookware Type			
Cake Pan	GM03COOKCP	Pie Pan	GM03COOKPP
Casserole Dish	GM03COOKCD	Pizza Pan	GM03COOKPI
Cookie Sheet	GM03COOKCS	Pressure Cooker	GM03COOKPC
Cupcake/Muffin Pan	GM03COOKCM	Roaster	GM03COOKRR
Dutch Oven	GM03COOKDU	Saucepan	GM03COOKSA
Frying Pan	GM03COOKFP	Sauté Pan	GM03COOKSE
Griddle	GM03COOKGR	Set	GM03COOKST
Lids and accessory	GM03COOKLA	Specialty	GM03COOKSP
Multi-Cooker/Stockpot	GM03COOKMS	Other	GM04COOK99

3.6.32 Corporate/Philanthropic Certifications Code List

Code List Values for Corporate/Philanthropic Certifications			
1% for the Planet	GM03COPHPL	NATURETEXTIL iVN certified BEST	GM03COPHNA
BCorp Certified	GM03COPHBC	Nordic Swan	GM03COPHNS
Blue Angel	GM03COPHBA	Other	GM04COPH99
EU Ecolabel	GM03COPHEU		

3.6.33 Crown Code List

Code List Values for Crown			
High	GM03CRWNHI	None	GM03CRWNNN
Low	GM03CRWNLW	Other	GM04CRWN99
Mid	GM03CRWNMD		

3.6.34 Cuff Type Code List

Code List Values for Cuff Type			
Barrel	GM03CFTPBA	No Cuff	GM03CFTPNC
Bottom Hem Cuffed	GM03CFTPBH	One Button	GM03CFTPBU
Elastic	GM03CFTPEL	Ribbed	GM03CFTPRB
Faux Fur	GM03CFTPPF	Thumb Hole	GM03CFTPTH
Folded	GM03CFTPFD	Two-Button	GM03CFTPTB
French	GM03CFTPFR	Other	GM04CFTP99
Mitered	GM03CFTPMI		

3.6.35 Dinnerware Category Code List

Code List Values for Dinnerware Category			
Everyday	GM03DNRCEV	Other	GM04DNRC99
Fine China	GM03DNRCFC		

3.6.36 Dress Type Code List

Code List Values for Dress Type			
A-line	GM03DRTPAL	Pencil	GM03DRTPPE
Babydoll	GM03DRTPBA	Peplum	GM03DRTPPL
Blouson	GM03DRTPBL	Popover	GM03DRTPPV
Body-Conscious	GM03DRTPBC	Sheath	GM03DRTPSE
Caftan	GM03DRTPCA	Shift	GM03DRTPSI
Circular	GM03DRTPCI	Shirtdress	GM03DRTPSD
Dress	GM03DRTPDR	Skater	GM03DRTPSK
Drop Waist	GM03DRTPDW	Skort	GM03DRTPSR
Empire Waist	GM03DRTPEW	Slipdress	GM03DRTPSL
Faux Wrap	GM03DRTPFW	Sweater Dress	GM03DRTPSW
Flared	GM03DRTPFL	Tank Dress	GM03DRTPTD
Full Skirt	GM03DRTPFS	Tiered	GM03DRTPTI
Gown	GM03DRTPGN	Two Piece	GM03DRTPTP
Jacket Dress	GM03DRTPJD	Wedding	GM03DRTPWE
Jumper	GM03DRTPJU	Wrap	GM03DRTPWR
Maternity	GM03DRTPMA	Other	GM04DRTP99
Mermaid/Trumpet	GM03DRTPMT		

3.6.37 Earring Type Code List

Code List Values for Earring Type			
Button	JW03EATPBU	Ear Wrap	JW03EATPEW
Chandelier	JW03EATPCH	Hoop	JW03EATPHP
Drop	JW03EATPDR	Stud	JW03EATPST
Ear Cuff	JW03EATPEC	Other	JW04EATP99
Ear Jacket	JW03EATPEJ		

3.6.38 Eyewear Type Code List

Code List Values for Eyewear Type			
Aviator	GM03EYESAV	Polarized Lenses	GM03EYESPL
Brow Bar	GM03EYESBB	Shield	GM03EYESSH
Cat Eye	GM03EYESCE	Wayfarer	GM03EYESWA
Clubmaster	GM03EYESCL	Wrap	GM03EYESWR
Mirrored Lenses	GM03EYESML	Other	GM04EYES99

3.6.39 Fabric or Material Code List

Code List Values for Fabric or Material			
14K Gold	GM03FBMC14	Marble/Wood	GM03FBMCMD
18K Gold	GM03FBMC18	Matte Jersey	GM03FBMCME
Agate	GM03FBMCAG	Melamine	GM03FBMCMF
Aluminum	GM03FBMCAL	Mercury Glass	GM03FBMCMG
Amethyst	GM03FBMCAM	Mesh	GM03FBMCMH
Anodized Aluminum	GM03FBMCAN	Metal	GM03FBMCMI
Beaded	GM03FBMCBD	Metal Alloy	GM03FBMCMJ
Birthstone	GM03FBMCBE	Metallic	GM03FBMCMK
Bi-stretch	GM03FBMCBF	Microfiber	GM03FBMCML
Bone	GM03FBMCBG	Microfleece	GM03FBMCMM
Boucle	GM03FBMCBH	Mikado	GM03FBMCMN
Brass	GM03FBMCBI	Mixed Materials	GM03FBMCMO
Broadcloth	GM03FBMCBJ	Mogador	GM03FBMCMQ
Brocade	GM03FBMCBL	Moleskin	GM03FBMCMQ
Bronze	GM03FBMCBN	Mother-of-Pearl	GM03FBMCMR
Brushed Back Satin	GM03FBMCBS	Natural	GM03FBMCNA



Brushed Back Terry	GM03FBMCBT	Natural Fiber	GM03FBMCNB
Burlap	GM03FBMCBU	Nonstick	GM03FBMCNC
Canvas	GM03FBMCCA	Nubuck	GM03FBMCND
Cashmink	GM03FBMCCB	Onyx	GM03FBMCOA
Cast Aluminum	GM03FBMCCC	Opal	GM03FBMCOB
Cast Iron	GM03FBMCCD	Organza	GM03FBMCOC
Ceramic	GM03FBMCCE	Ostrich	GM03FBMCOD
Challis	GM03FBMCCF	Ostrich Embossed	GM03FBMCOE
Chambray	GM03FBMCCG	Oxford	GM03FBMCOF
Charmeuse	GM03FBMCCH	Palladium	GM03FBMCPA
Chenille	GM03FBMCCI	Paper Braid	GM03FBMCPB
Chiffon/Sheer	GM03FBMCCJ	Patent Leather	GM03FBMCPC
Coated Canvas	GM03FBMCCK	Pearl	GM03FBMCPD
Composite	GM03FBMCCL	Percale	GM03FBMCP E
Confetti	GM03FBMCCM	Pinpoint	GM03FBMCPF
Copper	GM03FBMCCN	Pique	GM03FBMCPG
Coral	GM03FBMCCO	Plastic	GM03FBMCPH
Corduroy	GM03FBMCCP	Plastic/Acetate	GM03FBMCP I
Corian	GM03FBMCCQ	Plastic/Metal	GM03FBMCPJ
Cork	GM03FBMCCR	Plush	GM03FBMCPK
Crepe	GM03FBMCCS	Pointelle	GM03FBMCP L
Crinoline	GM03FBMCCT	Polycarbonate	GM03FBMCP M
Crochet	GM03FBMCCU	Ponte	GM03FBMCP N
Crochet/Openwork	GM03FBMCCV	Poplin	GM03FBMCP O
Croco	GM03FBMCCW	Porcelain	GM03FBMCP P
Croco Embossed	GM03FBMCCX	Portuguese Flannel	GM03FBMCP Q
Crystal	GM03FBMCCY	Propionate	GM03FBMCP R
Cubic Zirconia	GM03FBMCCZ	PU	GM03FBMCP S
Denim	GM03FBMCDA	Quartz	GM03FBMCQ A
Diamond	GM03FBMCDB	Rattan	GM03FBMCRA
Dobby	GM03FBMCDC	Resin	GM03FBMCRB
Double Knit	GM03FBMCDD	Rhodium	GM03FBMCRC

Down	GM03FBMCDE	Ribbon	GM03FBMCRD
Down Fill	GM03FBMCDF	Rope	GM03FBMCRE
Drop Needle	GM03FBMCDG	Saffiano	GM03FBMCSA
Earthenware	GM03FBMCEA	Sateen	GM03FBMCSB
Elephant Embossed	GM03FBMCEB	Satin	GM03FBMCSC
Enamel	GM03FBMCEC	Scuba	GM03FBMCSD
Enamel/Aluminum	GM03FBMCED	Seagrass	GM03FBMCSE
Enamel/Epoxy	GM03FBMCEF	Seersucker	GM03FBMCSF
Enamel/Iron	GM03FBMCEG	Sequin	GM03FBMCSG
Enamel/Steel	GM03FBMCEH	Shantung	GM03FBMCSH
End-on-End	GM03FBMCEI	Shearling	GM03FBMCSI
Epoxy	GM03FBMCEJ	Sheeting	GM03FBMCSJ
Eyelet	GM03FBMCEK	Shell	GM03FBMCSK
Fabric	GM03FBMCFA	Silicone	GM03FBMCSL
Faux Fur	GM03FBMCFB	Sinamay	GM03FBMCSM
Faux Leather	GM03FBMCFC	Slate	GM03FBMCSN
Faux Pearl	GM03FBMCFD	Slub	GM03FBMCSO
Faux Shearling	GM03FBMCFE	Snake Embossed	GM03FBMCSP
Faux Suede	GM03FBMCFF	Snit	GM03FBMCSQ
Felt	GM03FBMCFG	Stainless Steel	GM03FBMCSR
Flannel	GM03FBMCFH	Steel	GM03FBMCST
Flat Knit	GM03FBMCFI	Sterling Silver	GM03FBMCSU
Fleece	GM03FBMCFJ	Stone	GM03FBMCSV
Foam	GM03FBMCFK	Stoneware	GM03FBMCSW
French Terry	GM03FBMCFL	Straw	GM03FBMCSX
Fresh Water Pearl	GM03FBMCFM	Styrofoam	GM03FBMCSY
Fur	GM03FBMCFN	Suede	GM03FBMCSZ
Gabardine	GM03FBMCGA	Sweater Yarn	GM03FBMCSS
Galvanized	GM03FBMCGB	Swiss Dot	GM03FBMCWI
Gauze	GM03FBMCGC	Synthetic	GM03FBMCYT
Genuine Stone	GM03FBMCGD	Taffeta	GM03FBMCTA
Georgette	GM03FBMCGE	Terra Cotta	GM03FBMCTB

Glass	GM03FBMCGF	Terry Cloth	GM03FBMCTC
Glitter	GM03FBMCGI	Thermal	GM03FBMCTD
Grenadine	GM03FBMCGG	Titanium	GM03FBMCTE
Grosgrain	GM03FBMCGH	Topaz	GM03FBMCTF
Hard Anodized	GM03FBMCHA	Tricot	GM03FBMCTG
Hatchi	GM03FBMCHB	Tri-Ply Stainless Steel	GM03FBMCTH
Heavy Gauge Steel	GM03FBMCHC	Tritan	GM03FBMCTI
High-Carbon Steel	GM03FBMCHD	Tulle	GM03FBMCTJ
Hopsack	GM03FBMCHE	Turquoise	GM03FBMCTK
Howlite	GM03FBMCHF	Tweed	GM03FBMCTL
Ironstone	GM03FBMCIA	Tweed/Boucle	GM03FBMCTM
Jacquard	GM03FBMCJA	Twill	GM03FBMCTN
Jade	GM03FBMCJB	Velour	GM03FBMCVA
Jasper	GM03FBMCJC	Velvet	GM03FBMCVB
Knit (Generic)	GM03FBMCKA	Velveteen	GM03FBMCVC
Knit Cable	GM03FBMCKB	Voile	GM03FBMCVD
Knit Fine Gauge	GM03FBMCKC	Waffle	GM03FBMCWA
Knit Intarsia	GM03FBMCKD	Wax	GM03FBMCWB
Knit Interlock	GM03FBMCKE	Wicker	GM03FBMCWC
Knit Jersey	GM03FBMCKF	Wire	GM03FBMCWD
Knit Ribbed	GM03FBMCKG	Wood	GM03FBMCWE
Knit/Woven	GM03FBMCKH	Wood Alternative	GM03FBMCWF
Knitted	GM03FBMCKI	Wool	GM03FBMCWG
Lace	GM03FBMCLA	Woven (generic)	GM03FBMCWH
Leather	GM03FBMCLB	Other	GM03FBMC99
Lizard Embossed	GM03FBMCLC		
Magnesite	GM03FBMCMA		
Magnet	GM03FBMCMB		
Marble	GM03FBMCMC		

3.6.40 Fiber Code List

Code List Values for Fiber			
Acetate	GM03FIBRAA	Paper	GM03FIBRPA
Acrylic	GM03FIBRAB	Pashmina	GM03FIBRPB
Alpaca	GM03FIBRAC	Pigskin	GM03FIBRPC
Angora	GM03FIBRAD	Pima Cotton	GM03FIBRPD
Bamboo	GM03FIBRBA	Pima Cotton Blend	GM03FIBRPE
Buffalo	GM03FIBRBB	Polyester	GM03FIBRPF
Cashmere	GM03FIBRCA	Polyester Blend	GM03FIBRPG
Cotton	GM03FIBRCB	Polyester/Cotton	GM03FIBRPH
Cotton Blend	GM03FIBRCC	Polyester/Elastane	GM03FIBRPI
Cotton/Cashmere	GM03FIBRCD	Polyester/Modal	GM03FIBRPJ
Cotton/Elastane	GM03FIBRCE	Polyester/Nylon	GM03FIBRPK
Cotton/Lyocell	GM03FIBRCF	Polyester/Rayon	GM03FIBRPL
Cotton/Polyester	GM03FIBRCG	Polypropylene	GM03FIBRPM
Cotton/Polyester/Elastane	GM03FIBRCH	Polyurethane	GM03FIBRPN
Cotton/Rayon	GM03FIBRCI	PVC	GM03FIBRPO
Cotton/Silk	GM03FIBRCJ	Qmilch	GM03FIBRQM
Cow	GM03FIBRCK	Raffia	GM03FIBRRA
Deer	GM03FIBRDA	Ramie	GM03FIBRRB
Egyptian Cotton	GM03FIBREA	Rayon	GM03FIBRRC
Elastane	GM03FIBREB	Rayon (Viscose)	GM03FIBRRD
Flax	GM03FIBRFA	Rayon/Elastane	GM03FIBRRE
Goat	GM03FIBRGA	Rayon/Nylon	GM03FIBRRF
Hair On Hide	GM03FIBRHA	Rayon/Nylon/Elastane	GM03FIBRRG
Haircalf	GM03FIBRHB	Rhino	GM03FIBRRH
Hemp	GM03FIBRHC	Rubber	GM03FIBRRI
Horse Hair	GM03FIBRHD	Sheepskin	GM03FIBRSA
Jute	GM03FIBRJA	Silk	GM03FIBRSB
Lamb	GM03FIBRLA	Sisal	GM03FIBRSC

Lambs Wool/Nylon	GM03FIBRLB	Snake	GM03FIBRSD
Leather	GM03FIBRLC	Supplex	GM03FIBRSE
Leather/Nylon	GM03FIBRLD	Supplex/Elastane	GM03FIBRSF
Linen	GM03FIBRLE	Turkish Cotton	GM03FIBRTA
Linen/Cotton	GM03FIBRLF	UGG Wool	GM03FIBRUA
Linen/Silk	GM03FIBRLG	Vinyl	GM03FIBRVA
Lurex	GM03FIBRLH	Viscose	GM03FIBRVB
Lyocell	GM03FIBRLI	Wool	GM03FIBRWA
Metallic Yarn	GM03FIBRMA	Wool Blend	GM03FIBRWB
Microcotton	GM03FIBRMB	Wool/Bamboo	GM03FIBRWC
Microfiber	GM03FIBRMC	Wool/Cashmere	GM03FIBRWD
Modal	GM03FIBRMD	Wool/Elastane	GM03FIBRWE
Modal/Elastane	GM03FIBRME	Wool/Nylon/Cashmere	GM03FIBRWF
Mohair	GM03FIBRMF	Wool/Silk	GM03FIBRWG
Neoprene	GM03FIBRNA	Other	GM03FIBR99
Nylon	GM03FIBRNB		
Nylon/Elastane	GM03FIBRNC		
Olefin	GM03FIBROA		

3.6.41 Fill Material Code List

Code List Values for Fill Material			
Down	GM03FILMDW	Natural Fill	GM03FILMNA
Down Alternative	GM03FILMDA	Nylon Fill	GM03FILMNY
Down/Feather	GM03FILMDF	Polyfill	GM03FILMPY
Feather	GM03FILMFE	Synthetic	GM03FILMSY
Latex Foam	GM03FILMLF	Other	GM04FILM99
Memory Foam	GM03FILMMF		

3.6.42 Finish Code List

Code List Values for Finish			
Acid Washed	GM03FNSHAW	Patent	GM03FNSHPA
Antique	GM03FNSHAN	Polished	GM03FNSHPL
Brushed	GM03FNSHBR	Raw/Dry	GM03FNSHRD
Coated	GM03FNSHCT	Rub-Off	GM03FNSHRB
Distressed	GM03FNSHDI	Satin	GM03FNSHSA
Dual/Etched	GM03FNSHDE	Shiny	GM03FNSHSH
Embossed	GM03FNSTEM	Stone Wash	GM03FNSHSW
Matte	GM03FNSHMA	Velvet	GM03FNSHVE
Matte/Frosted	GM03FNSHMF	Washed	GM03FNSHWA
Metallic	GM03FNSHME	Other	GM04FNSH99
Nappa	GM03FNSHNA		

3.6.43 Fit Code List

Code List Values for Fit			
Relaxed	GM03FITTRE	Other	GM04FIT99
Structured	GM03FITST		

3.6.44 Flatware Type Code List

Code List Values for Flatware Type			
Butter Knife	GM03FLATBU	Pasta Server	GM03FLATPA
Cake Knife	GM03FLATCA	Pierced Serving Spoon	GM03FLATPI
Carving Fork	GM03FLATCR	Salad Fork	GM03FLATSA
Cocktail Fork	GM03FLATCC	Serving Fork	GM03FLATSF
Cocktail Spoon	GM03FLATCS	Serving Spoon	GM03FLATSS
Dessert Server	GM03FLATDE	Soup Spoon	GM03FLATSP
Dinner Fork	GM03FLATDI	Spoon	GM03FLATSN
Fork	GM03FLATFK	Spreader Knife	GM03FLATSK
Ice Tea Spoon	GM03FLATIC	Steak Knife	GM03FLATST
Knife	GM03FLATKN	Sugar Spoon	GM03FLATSU
Ladle	GM03FLATLD	Tablespoon	GM03FLATTA
Lasagna Server	GM03FLATLS	Teaspoon	GM03FLATTE
Luncheon Fork	GM03FLATLF	Tongs	GM03FLATTG
Luncheon Knife	GM03FLATLK	Other	GM04FLAT99

3.6.45 Formulation Code List

Code List Values for Formulation			
Capsules	GM03FORMCA	Mousse/Foam	GM03FORMMF
Cream	GM03FORMCR	Oil	GM03FORMIL
Cream-To-Powder	GM03FORMCP	Paste	GM03FORMPS
Gel	GM03FORMGL	Pressed Powder	GM03FORMPP
Liquid	GM03FORMLQ	Solid	GM03FORMSL
Loose Powder	GM03FORMLP	Wax	GM03FORMWX
Lotion	GM03FORMLT	Wipe	GM03FORMWP
Mist/Spray	GM03FORMMS	Other	GM04FORM99

3.6.46 Fur Animal Name Code List

Code List Values for Fur Animal Name			
Australian Brushtail Possum	GM03FANMAP	Otter	GM03FANMOU
Beaver	GM03FANMBV	Pony Hair	GM03FANMPH
Calf Hair	GM03FANMCH	Rabbit	GM03FANMRI
Fox	GM03FANMFX	Raccoon	GM03FANMRC
Golden Jackal	GM03FANMGJ	Sable	GM03FANMSG
Grey Wolf	GM03FANMGW	Skunk	GM03FANMSK
Marten	GM03FANMMA	Other Fur Animal*	GM04FANM99
Mink	GM03FANMMK		

* Requires use of PID05

3.6.47 Fur Treatment Code List

Code List Values for Fur Treatment	
Artificially Colored	GM03FTMTAC
Bleached	GM03FTMTBM
Dyed	GM03FTMTDY
Natural (untreated)	GM03FTMTNA
Painted	GM03FTMTPT
Other Fur Treatment*	GM04FTMT99

* Requires use of PID05

3.6.48 Gauge Code List

Code List Values for Gauge			
16lbs Dozen	GM03GAUGSX	Opaque	GM03GAUGPQ
Fine	GM03GAUGFI	Semi-Opaque	GM03GAUGSE
Heavy	GM03GAUGHV	Sheer	GM03GAUGSH
Heavyweight	GM03GAUGHW	Super Opaque	GM03GAUGSU
Light	GM03GAUGLI	Other	GM04GAUG99
Medium	GM03GAUGMD		

3.6.49 Gender Code List

Code List Values for Gender			
Female	ZZ03GENDFE	Gender Neutral	ZZ03GENDUN
Male	ZZ03GENDMA		

3.6.50 Glove Type Code List

Code List Values for Hat Type			
Mitten	GM03GLTYMI	Flip Top	GM03GLTYFL
Fingerless	GM03GLTYFI	Lobster Gel	GM03GLTYLG
Tech	GM03GLTYTE	Other	GM04GLTY99
Traditional	GM03GLTYTR		

3.6.51 Hat Code List

Code List Values for Hat Type			
Balaclava	GM03HATSBL	Floppy	GM03HATSFL
Baseball Cap	GM03HATSBS	Newsboy	GM03HATSNW
Beanie	GM03HATSBE	Panama	GM03HATSPN
Beret	GM03HATSBR	Slouchy	GM03HATSSL
Boater	GM03HATSBA	Snap Back	GM03HATSSN
Bonnet	GM03HATSBN	Sun Hat	GM03HATSSH
Bowler	GM03HATSBW	Trapper	GM03HATSTR
Bucket Hat	GM03HATSBH	Trucker	GM03HATSTU
Cowboy	GM03HATSCW	Visor	GM03HATSVS
Ear Muffs	GM03HATSEM	Wide Brim	GM03HATSWB

Fedora	GM03HATSFD	Other	GM04HATS99
--------	------------	-------	------------

3.6.52 Heel Height Range Code List

Code List Values for Heel Height Range			
Extra-High > 3 inch	GM03HLHTEH	Low - >.5 to 1 inch	GM03HLHTLW
Flat - 0-.5 inch	GM03HLHTFL	Medium - > 1 inch - 2 inch	GM03HLHTMD
High > 2 inch - 3 inch	GM03HLHTHI	Other	GM04HLHT99

3.6.53 Heel Material Code List

Code List Values for Heel Material			
Cork	GM03HLMTCK	Synthetic	GM03HLMTSY
Leather	GM03HLMTLE	Textile/Fabric	GM03HLMTTE
Metallic	GM03HLMTME	Wood	GM03HLMTWD
Rope	GM03HLMTRP	Other	GM04HLMT99

3.6.54 Heel Type Code List

Code List Values for Heel Type			
Block	GM03HLTYBL	No Heel/Flat	GM03HLTYNH
Comma	GM03HLTYCM	Novelty	GM03HLTYNV
Cone	GM03HLTYCN	Spool	GM03HLTYSP
Demi-Wedge	GM03HLTYDW	Stacked	GM03HLTYSA
Flare	GM03HLTYFL	Stiletto/Pointed	GM03HLTYSL
Platform	GM03HLTYFF	Wedge	GM03HLTYWE
Kitten	GM03HLTYKI	Other	GM04HLTY99
Louis	GM03HLTYLU		

3.6.55 Holiday/Event Code List

Code List Values for Holiday/Event			
Christmas	ZZ03HOEVCH	New Year's	ZZ03HOEVNY
Easter	ZZ03HOEVEA	St. Patrick's Day	ZZ03HOEVSP
Father's Day	ZZ03HOEVFA	Thanksgiving	ZZ03HOEVTH
Fourth of July	ZZ03HOEVFJ	Valentine's Day	ZZ03HOEVVA

Halloween	ZZ03HOEVHA	Wedding	ZZ03HOEVWE
Hanukkah	ZZ03HOEVHU	Other	ZZ04HOEV99
Mother's Day	ZZ03HOEVMD		

3.6.56 Hosiery/Sock Type Code List

Code List Values for Hosiery/Sock Type			
Arm Warmer	GM03HOSOAW	No Show	GM03HOSONS
Crew	GM03HOSOCR	Over the Calf	GM03HOSOOC
Footless Tights	GM03HOSOFT	Over the Knee	GM03HOSOOK
Knee High	GM03HOSOKH	Quarter	GM03HOSOQU
Leggings	GM03HOSOLG	Thigh High	GM03HOSOTH
Legwarmer	GM03HOSOLW	Tights	GM03HOSOTG
Liner	GM03HOSOLI	Trouser	GM03HOSOTR
Low Cut	GM03HOSOLC	Other	GM04HOSO99

3.6.57 Jewelry Sets Code List

Code List Values for Jewelry Sets			
Bracelet/Ears	JW03JWSTBE	Neck/Ears/Bracelet	JW03JWSTNB
Neck/Ears	JW03JWSTNE	Other	JW04JWST99

3.6.58 Jewelry Type Code List

Code List Values for Jewelry Type			
Costume	JW03JWLTC	Fine	JW03JWLTFI
Fashion	JW03JWLTF	Other	JW04JWLT99

3.6.59 Knit Type Code List

Code List Values for Knit Type			
Pom	GM03KNITPM	Tassel	GM03KNITSK
Skully	GM03KNITTA	Other	GM04KNIT99

3.6.60 League Code List

Code List Values for League			
CFL	ZZ03LEAGCF	NBA	ZZ03LEAGNB
Indy Car	ZZ03LEAGIC	NCAA	ZZ03LEAGNC
International Soccer	ZZ03LEAGIS	NFL	ZZ03LEAGNF
LPGA	ZZ03LEAGLP	NHL	ZZ03LEAGNH
Mexican League	ZZ03LEAGME	Olympics	ZZ03LEAGLM
Mexican Pacific League	ZZ03LEAGMP	PGA	ZZ03LEAGPG
MiLB	ZZ03LEAGMI	UFC	ZZ03LEAGUF
MLB	ZZ03LEAGML	WWE	ZZ03LEAGWW
MLS	ZZ03LEAGMS	Other	ZZ04LEAG99
NASCAR	ZZ03LEAGNS		

3.6.61 Leg Type Code List

Code List Values for Leg Type			
Boot Cut	GM03LGTYBC	Tapered	GM03LGTYTA
Flare Leg	GM03LGTYFL	Wide Leg	GM03LGTYWI
Skinny Leg	GM03LGTYSK	Other	GM04LGTY99
Straight Leg	GM03LGTYST		

3.6.62 *Leather Animal Name Code List*

Code List Values for Leather Animal Name			
Alligator	GM03LEANAL	Lamb	GM03LEANLA
Buffalo	GM03LEANBU	Lizard	GM03LEANLI
Calf	GM03LEANCA	Ostrich	GM03LEANOS
Cod	GM03LEANCO	Perch	GM03LEANPE
Cow	GM03LEANCW	Pig	GM03LEANPI
Deer	GM03LEANDE	Rabbit	GM03LEANRA
Eel	GM03LEANEE	Salmon	GM03LEANSL
Elk	GM03LEANEL	Sheep	GM03LEANSH
Frog/Toad	GM03LEANFR	Snake	GM03LEANSN
Goat	GM03LEANGO	Stingray	GM03LEANST
Horse	GM03LEANHO	Tilapia	GM03LEANTI
Kangaroo	GM03LEANKA	Wolfish	GM03LEANWO
		Other	GM04LEAN99

3.6.63 Length Description Code List

Code List Values for Length Description			
Above Knee	GM03LNTHAK	Midi Short	GM03LNTHMS
Ankle	GM03LNTHAN	Mini	GM03LNTHMN
Basketball	GM03LNTHBA	Regular/Full	GM03LNTHRF
Below Knee	GM03LNTHBK	Short	GM03LNTHST
Capri/Calf	GM03LNTHCC	Skimmer	GM03LNTHSK
Car	GM03LNTHCA	Tall	GM03LNTHTA
Cropped	GM03LNTHCR	Tea/Ballet	GM03LNTHTB
Extra Long	GM03LNTHEL	Tunic	GM03LNHTTU
High-Low	GM03LNTHHL	Waist	GM03LNTHWA
Knee	GM03LNTHKN	Walker	GM03LNTHWK
Long	GM03LNTHLN	Waltz	GM03LNTHWZ
Maxi	GM03LNTHMX	Other	GM04LNTH99
Mid	GM03LNTHMD		

3.6.64 Lined Code List

Code List Values for Lined			
Fully Lined	GM03LINDFL	Other	GM04LIND99
Semi-Lined	GM03LINDSL		

3.6.65 Lining Material Code List

Code List Values for Lining Material (LIMT)			
Antimicrobial	GM03LIMTAN	Nylon	GM03LIMTNY
Cotton	GM03LIMTCT	Organic Material	GM03LIMTOM
Fabric	GM03LIMTFD	Polyester	GM03LIMTPR
Faux Fur	GM03LIMTFB	PU	GM03LIMTPU
Faux Leather	GM03LIMTFL	PVC	GM03LIMTPV
Faux Shearling	GM03LIMTFS	Quilted	GM03LIMTQT
Fleece	GM03LIMTFC	Shearling Lined	GM03LIMTSL
Gel	GM03LIMTGE	Sherpa	GM03LIMTSP
Leather	GM03LIMTLE	Straw	GM03LIMTST
Logo Lining	GM03LIMTLL	Synthetic	GM03LIMTSY
Memory Foam	GM03LIMTMF	Taffeta	GM03LIMTTA
Mesh	GM03LIMTME	Other	GM04LIMT99

* Requires use of PID05

3.6.66 Metal Code List

Code List Values for Metal			
Aluminum	JW03METLAI	Platinum	JW03METLPT
Brass	JW03METLBR	Rhodium	JW03METLRH
Bronze	JW03METLBZ	Rose Gold	JW03METLRG
Cast Iron	JW03METLCI	Silver	JW03METLAG
Copper	JW03METLCU	Stainless Steel	JW03METLSS
Gold	JW03METLAU	Titanium	JW03METLTI
Gold Plated	JW03METLGP	White Gold	JW03METLWG
Nickel	JW03METLNI	Other	JW04METL99
Palladium	JW03METLPD		

3.6.67 Metal Composition Code List

Code List Values for Metal Composition			
18/0	GM03MTLCCA	Other	GM04MTLC99
18/10	GM03MTLCCB		
18/8	GM03MTLCCC		

3.6.68 Necklace Type Code List

Code List Values for Necklace Type			
Chain	JW03NKLCCA	Pearl Strand	JW03NKLCPSP
Choker	JW03NKLCCB	Pendant	JW03NKLCPD
Collar	JW03NKLCCCL	Y-Necklace	JW03NKLCCYN
Locket	JW03NKLCLK	Other	JW04NKLCC99
Multi Strand	JW03NKLCCMS		

3.6.69 Neckwear Type Code List

Code List Values for Neckwear Type			
Bandana	GM03NECKBN	Neck Tie	GM03NECKNT
Boa	GM03NECKBA	Oblong Scarf	GM03NECKBS
Bolo	GM03NECKBL	Sarong/Pareo	GM03NECKSP
Bow Tie	GM03NECKBT	Square Scarf	GM03NECKSS
Clip-On Tie	GM03NECKCT	Stole	GM03NECKST
Cravat	GM03NECKCR	Wrap/Shawl	GM03NECKWS
Infinity Scarf	GM03NECKIS	Other	GM04NECK99
Muffler	GM03NECKMU		

3.6.70 Number of Settings Code List

Code List Values for Number of Settings			
Eight	GM03SETSEI	Twelve	GM03SETSTW
Four	GM03SETSFR	Other	GM04SETS99
Six	GM03SETSSX		

3.6.71 Occasion Code List

Code List Values for Occasion			
Active/Workout	GM03OCCNAW	Evening	GM03OCCNEV
Anniversary	GM03OCCNAN	Fashion	GM03OCCNFA
Athleisure	GM03OCCNAL	Flower Girl	GM03OCCNFG
Athletic	GM03OCCNAT	Formal	GM03OCCNFR
Baby Shower	GM03OCCNBS	Graduation	GM03OCCNGG
Beach/Pool	GM03OCCNBP	Groom	GM03OCCNGM
Birthday	GM03OCCNBI	Homecoming	GM03OCCNHM
Bride	GM03OCCNBR	Lounge	GM03OCCNLN
Bridesmaid	GM03OCCNBD	Mother of the Bride	GM03OCCNMB
Career	GM03OCCNCR	Outdoor	GM03OCCNUT
Casual	GM03OCCNCS	Performance	GM03OCCNPE
Christening/Baptism	GM03OCCNCB	Prom	GM03OCCNPR
Cocktail	GM03OCCNCT	Resort	GM03OCCNRE
Comfort	GM03OCCNCF	Ring Bearer	GM03OCCNRB
Communion	GM03OCCNCM	Safety	GM03OCCNSA
Daytime	GM03OCCNDT	Wedding	GM03OCCNSU
Dress	GM03OCCNDR	Work/Uniform	GM03OCCNWU
Easter	GM03OCCNEA	Other	GM04OCCN99
Engagement	GM03OCCNEN		

3.6.72 Outsole Type Code List

Code List Values for Outsole Type			
Dimpled	GM03OUTSDP	Non-Slip	GM03OUTSNS
Driver	GM03OUTSDR	Tooth	GM03OUTSTT
Embossed	GM03OUTSEM	Tread	GM03OUTSTR
Heavy Lug	GM03OUTSHV	Other	GM04OUTS99
Light Lug	GM03OUTSLL		

3.6.73 Open/Closed Toe Code List

Code List Values for Open/Closed Toe			
Closed	GM03OPCLCL	Open	GM03OPCLOP

3.6.74 Pants/Shorts Type Code List

Code List Values for Pants/Shorts Type			
5 Pocket/Jean	GM03PTSHFJ	GaUCHO/Palazzo	GM03PTSHGP
Bermuda	GM03PTSHBE	Jogger	GM03PTSHJG
Boxer	GM03PTSHBX	Leggings	GM03PTSHLE
Capri	GM03PTSHCA	Pleated	GM03PTSHPL
Cargo	GM03PTSHCG	Skort	GM03PTSHSK
Carpenter	GM03PTSHCP	Sweatpant	GM03PTSHSW
Chino	GM03PTSHCH	Tap	GM03PTSHTA
Culotte	GM03PTSHCL	Track	GM03PTSHTR
Cut Off	GM03PTSHCT	Trouser	GM03PTSHTU
Flat Front	GM03PTSHFF	Other	GM04PTSH99

3.6.75 Panty Back Coverage Code List

Code List Values for Panty Back Coverage			
Cheeky	GM03PNBCCH	Medium	GM03PNBCMD
Full	GM03PNBCFL	Other	GM03PNBC99

3.6.76 Panty Type Code List

Code List Values for Panty Type			
Bikini	GM03PNTYBI	Retro Thong	GM03PNTYRT
BoysShort	GM03PNTYBO	Seamless	GM03PNTYSE
French Cut	GM03PNTYFC	Shorty	GM03PNTYSH
Full Brief	GM03PNTYFL	String	GM03PNTYST
Hi Cut	GM03PNTYHC	Tanga	GM03PNTYTA
High Waist Brief	GM03PNTYHB	Thong	GM03PNTYTH
High Waist Thong	GM03PNTYHT	Other	GM03PNTY99
Hipster	GM03PNTYHP		

3.6.77 Primary Detail Application Code List

Code List Values for Primary Detail Application			
Applique	GM03PDAPAP	Logo Pin	GM03PDAPLP
Banded	GM03PDAPBA	Metallic Ink	GM03PDAPMI
Bling	GM03PDAPBL	Patch	GM03PDAPPA
Cut	GM03PDAPCU	Printed	GM03PDAPPR
Decal	GM03PDAPDE	Printed Tackle Twill	GM03PDAPPT
Embossed	GM03PDAPEM	Raised Embroidery	GM03PDAPRE
Etched	GM03PDAPET	Reactive Glaze	GM03PDAPRG
Fabric Applique	GM03PDAPFA	Reflective Applique	GM03PDAPRA
Felt Applique	GM03PDAPFE	Reflective Screen Print	GM03PDAPRS
Flat Embroidered	GM03PDAPFM	Rhinestone	GM03PDAPRH
Foil	GM03PDAPFL	Screen Print	GM03PDAPSP
Glitter	GM03PDAPGL	Sequins	GM03PDAPSE
Hand Painted	GM03PDAPHP	Tackle Twill	GM03PDAPTT
Heat Seal	GM03PDAPHS	Woven	GM03PDAPWV
High-Density Ink	GM03PDAPHD	Other	GM04PDAP99
Jacquard Knit	GM03PDAPJN		

3.6.78 Primary Detail Placement Code List

Code List Values for Primary Detail Placement			
All Over	GM03PDPLAA	Front Pocket	GM03PDPLFP
Back Bottom	GM03PDPLBB	Front Right	GM03PDPLFR
Back Center	GM03PDPLBC	Front Top	GM03PDPLFT
Back Left	GM03PDPLBL	Full Body	GM03PDPLFD
Back Pocket	GM03PDPLBP	Full Front	GM03PDPLFF
Back Right	GM03PDPLBR	Hem	GM03PDPLHE
Back Top	GM03PDPLBT	Left Leg	GM03PDPLLL
Bill	GM03PDPLBI	Left Sleeve	GM03PDPLLS
Collar	GM03PDPLCL	Leg	GM03PDPLLE
Cuff	GM03PDPLCU	Right Leg	GM03PDPLRL
Front Bottom	GM03PDPLFB	Right Sleeve	GM03PDPLRS
Front Center	GM03PDPLFC	Sleeve	GM03PDPLSL
Front Left	GM03PDPLFL	Other	GM04PDPL99

3.6.79 Primary Detail Size Code List

Code List Values for Primary Detail Size			
Large	GM03PDSZLG	Small	GM03PDSZSM
Medium	GM03PDSZMD	Other	GM04PDSZ99

3.6.80 Primary Detail Type Code List

Code List Values for Primary Detail Type			
Brand	GM03PDTPBR	Player Name	GM03PDTPPN
League	GM03PDTPLE	Script	GM03PDTPSC
Letter	GM03PDTPLT	Team	GM03PDTPTE
Mascot	GM03PDTPMA	Wordmark	GM03PDTPWM
Number	GM03PDTPNU	Other	GM04PDTP99
Patch	GM03PDTPPA		

3.6.81 Primary Motif Theme Code List

Code List Values for Primary Motif Theme			
Americana	GM03PMTTAM	Character	GM03PMTTCH
Animal	GM03PMTTAN	Other	GM04PMTT99

3.6.82 Raw Materials Certifications Code List

Code List Values for Raw Materials Certifications			
BASF e3	GM03RAMABA	Regenagri	GM03RAMARG
Certified Vegan	GM03RAMACV	Regenerative Organic Certified (ROC)	GM03RAMARO
Cotton Made in Africa (CMiA)	GM03RAMACM	Responsible Alpaca Standard (RAS)	GM03RAMARA
Downpass Standard	GM03RAMADS	Responsible Down Standard (RDS)	GM03RAMARD
Fibershed	GM03RAMAFI	Responsible Mohair Standard (RMS)	GM03RAMARM
Forest Stewardship Council (FSC)	GM03RAMAFS	Responsible Wool Standard (RWS)	GM03RAMARW
Global Organic Textile Standard (GOTS)	GM03RAMAGO	Roundtable on Sustainable Biomaterials (RSB)	GM03RAMARS
Global Recycled Standard (GRS)	GM03RAMAGR	Soil Association Certified Organic	GM03RAMASA
Global Cashmere Standard	GM03RAMAGC	Sustainable Fibre Alliance (SFA) certified	GM03RAMASF
Leather Working Group	GM03RAMALW	Traumpass Label	GM03RAMATR
NewMerino	GM03RAMANM	USCTP (US Cotton Trust Protocol)	GM03RAMAUS
Organic (US, EU or UK standards)	GM03RAMAOR	USDA Certified Biobased	GM03RAMAUB
Organic Cotton Standard (OCS)	GM03RAMAOC	USDA Certified Organic	GM03RAMAUD
PETA Certified Vegan	GM03RAMAPV	Vegan Trademark	GM03RAMAVT
ReCot	GM03RAMART	ZQ Certified Merino Label	GM03RAMAZQ
ReDown	GM03RAMARD	Other	GM04RAMA99
REEL Cotton	GM03RAMARE		

3.6.83 Ring Type Code List

Code List Values for Ring Type			
Band	JW03RINGBA	Stacked	JW03RINGST
Midi	JW03RINGMI	Toe	JW03RINGTE
Signet	JW03RINGSI	Other	JW04RING99

3.6.84 Rug Type Code List

Code List Values for Rug Type			
Accent	GM03RUGTAC	Outdoor	GM03RUGTUT
Bath	GM03RUGTBA	Rug Pad	GM03RUGTRP
Dining Room	GM03RUGTDR	Runners	GM03RUGTRU
Doormat	GM03RUGTDM	Other	GM04RUGT99
Kitchen	GM03RUGTKI		

3.6.85 Scarf Type Code List

Code List Values for Scarf Type			
Blanket	GM03SCTYBL	Oblong	GM03SCTYOB
Bandana/Neckerchief	GM03SCTYBA	Poncho	GM03SCTYPO
Boa	GM03SCTYBO	Pull-through	GM03SCTYPU
Buff	GM03SCTYBU	Shawl	GM03SCTYSH
Cowl	GM03SCTYCO	Snood	GM03SCTYSN
Evening	GM03SCTYEV	Square	GM03SCTYSQ
Gaiter	GM03SCTYGA	Stole	GM03SCTYST
Head Scarf	GM03SCTYHS	Triangle	GM03SCTYTR
Infinity	GM03SCTYIN	Turban	GM03SCTYTU
Muffler	GM03SCTYMU	Wrap	GM03SCTYWR
Necklace	GM03SCTYNE	Other	GM04SCTY99

3.6.86 Scent Type Code List

Code List Values for Scent Type			
Aquatic	GM03SCTPAQ	Oriental	GM03SCTPOR
Citrus	GM03SCTPCI	Powdery	GM03SCTPPW
Earthy	GM03SCTPEA	Spicy	GM03SCTPSP
Earthy and Woody	GM03SCTPEW	Sweet	GM03SCTPSW
Floral	GM03SCTPFL	Unscented	GM03SCTPUS
Fresh and Clean	GM03SCTPFC	Vanilla	GM03SCTPVA
Fruity	GM03SCTPFR	Warm and Spicy	GM03SCTPWS
Mixed	GM03SCTPMI	Woody	GM03SCTPWD
Musk	GM03SCTPMU	Other	GM04SCTP99

3.6.87 Seams Code List

Code List Values for Seams			
Adhesive	IA03SEAMAD	Raised	IA03SEAMRA
Bonded	IA03SEAMBO	Seamed	IA03SEAMSA
Flat	IA03SEAMFL	Seamless	IA03SEAMSE
Laser Cut	IA03SEAMLC	Other	IA04SEAM99

3.6.88 Secondary Detail Application Code List

Code List Values for Secondary Detail Application			
Applique	GM03SDAPAP	Logo Pin	GM03SDAPLP
Banded	GM03SDAPBA	Metallic Ink	GM03SDAPMI
Bling	GM03SDAPBL	Patch	GM03SDAPPA
Cut	GM03SDAPCU	Printed	GM03SDAPPR
Decal	GM03SDASDE	Printed Tackle Twill	GM03SDAPPT
Embossed	GM03SDAPEM	Raised Embroidery	GM03SDAPRE
Etched	GM03SDAPET	Reactive Glaze	GM03SDAPRG
Fabric Applique	GM03SDAPFA	Reflective Applique	GM03SDAPRA
Felt Applique	GM03SDAPFE	Reflective Screen Print	GM03SDAPRS
Flat Embroidered	GM03SDAPFM	Rhinestone	GM03SDAPRH
Foil	GM03SDAPFL	Screen Print	GM03SDAPSP
Glitter	GM03SDAPGL	Sequins	GM03SDAPSE
Hand Painted	GM03SDAPHP	Tackle Twill	GM03SDAPTT
Heat Seal	GM03SDAPHS	Woven	GM03SDAPWV
High-Density Ink	GM03SDAPHD	Other	GM04SDAP99
Jacquard Knit	GM03SDAPJN		

3.6.89 Secondary Detail Placement Code List

Code List Values for Secondary Detail Placement			
All Over	GM03SDPLAA	Front Pocket	GM03SDPLFP
Back Bottom	GM03SDPLBB	Front Right	GM03SDPLFR
Back Center	GM03SDPLBC	Front Top	GM03SDPLFT
Back Left	GM03SDPLBL	Full Body	GM03SDPLFD
Back Pocket	GM03SDPLBP	Full Front	GM03SDPLFF
Back Right	GM03SDPLBR	Hem	GM03SDPLHE
Back Top	GM03SDPLBT	Left Leg	GM03SDPLLL
Bill	GM03SDPLBI	Left Sleeve	GM03SDPLLS
Collar	GM03SDPLCL	Leg	GM03SDPLLE
Cuff	GM03SDPLCU	Right Leg	GM03SDPLRL
Front Bottom	GM03SDPLFB	Right Sleeve	GM03SDPLRS
Front Center	GM03SDPLFC	Sleeve	GM03SDPLSL
Front Left	GM03SDPLFL	Other	GM04SDPL99

3.6.90 Secondary Detail Size Code List

Code List Values for Secondary Detail Size			
Large	GM03SDSZLG	Small	GM03SDSZSM
Medium	GM03SDSZMD	Other	GM04SDSZ99

3.6.91 Secondary Detail Type Code List

Code List Values for Secondary Detail Type			
Brand	GM03SDTPBR	Player Name	GM03SDTPPN
League	GM03SDTPLE	Script	GM03SDTPSC
Letter	GM03SDTPLT	Team	GM03SDTPTE
Mascot	GM03SDTPMA	Wordmark	GM03SDTPWM
Number	GM03SDTPNU	Other	GM04SDTP99
Patch	GM03SDTPPA		

3.6.92 Secondary Motif Theme Code List

Code List Values for Secondary Motif Theme			
Americana	GM03SMTTAM	Character	GM03SMTTCH
Animal	GM03SMTTAN	Other	GM04SMTT99

3.6.93 Selling Channel Code List

Code List Values for Selling Channel			
In store only	ZZ03SELCIS	Online only	ZZ03SELCON
Drop Ship	ZZ03SELCDS	Other	ZZ04SELC99
No restrictions	ZZ03SELCNR		

3.6.94 Shape Code List

Code List Values for Shape			
Bedrest	GM03SHPEBE	Rectangular	GM03SHPERE
Bolster	GM03SHPEBL	Round	GM03SHPERO
Breakfast/Boudoir	GM03SHPEBB	Shaped/Novelty	GM03SHPESN
Figure/Shaped	GM03SHPEFS	Soft Square	GM03SHPESS
Lumbar	GM03SHPELU	Square	GM03SHPESQ
Neckroll	GM03SHPENE	Triangle	GM03SHPETR
Oval/Oblong	GM03SHPEVB	Other	GM04SHPE99

3.6.95 Shapewear Type Code List

Code List Values for Shapewear Type			
Body Shaper (to the knee)	GM03SWRTBS	Open Bust Shaper	GM03SWRTOB
Bodysuit (to the ankle)	GM03SWRTBU	Shaping Slip	GM03SWRTSH
Camisole/Tank	GM03SWRTCA	Thigh Slimmer	GM03SWRTTS
Control Panty	GM03SWRTCP	Waist Trainer	GM03SWRTWT
Legging	GM03SWRTLK	Other	GM03SWRT99

3.6.96 Shoe Style Code List

Code List Values for Shoe Style			
Alpine Boot	GM03SHOEAB	Instep Strap	GM03SHOEIS
Ankle Strap	GM03SHOEAS	Low Top	GM03SHOELT
Athleisure	GM03SHOEAT	Jellies	GM03SHOEJE
Ballet	GM03SHOEBA	Mary Jane	GM03SHOEMJ
Biker Boot	GM03SHOEBI	Military & Police	GM03SHOEMP
Boat Shoe	GM03SHOEBS	Moccasin	GM03SHOEMC
Bootie	GM03SHOEBT	Monk Strap	GM03SHOEMS
Caged	GM03SHOECA	Penny Loafer	GM03SHOEPE
Chelsea	GM03SHOECH	Rain Boot	GM03SHOERA
Chukka	GM03SHOECK	Riding Boot	GM03SHOERI
Cleats	GM03SHOECL	Shootie	GM03SHOESH
Combat Boot	GM03SHOECB	Slide	GM03SHOESL
Comfort	GM03SHOECF	Sling Back	GM03SHOESB
Cowboy	GM03SHOECW	Slip On	GM03SHOESO
Derby	GM03SHOEDE	Smoking Slipper	GM03SHOESM
D'Orsay	GM03SHOEDR	Snow Boot	GM03SHOESW
Driver	GM03SHOEDV	Sport Specific	GM03SHOESS
Espadrille	GM03SHOEES	Strappy	GM03SHOESY
Fisherman	GM03SHOEFI	T-Strap	GM03SHOETS
Flip-Flop	GM03SHOEFP	Thong	GM03SHOETH
Ghillie	GM03SHOEGH	Water Shoe	GM03SHOEWS
Gladiator	GM03SHOEGL	Wingtip	GM03SHOEWT
High Top	GM03SHOEHT	Work Boot	GM03SHOEWB
Huarache	GM03SHOEHU	Other	GM04SHOE99

3.6.97 Shoe Type Code List

Code List Values for Shoe Type			
Boots/Booties	GM03SETPBB	Pumps	GM03SETPPP
Clogs/Mules	GM03SETPCM	Sandals	GM03SETPSA
Flats	GM03SETPFL	Slippers	GM03SETPSL
Loafers	GM03SETPLM	Sneakers	GM03SETPSN
Oxfords	GM03SETPXF	Other	GM04SETP99

3.6.98 Skin Type Code List

Code List Values for Skin Type			
Aging	GM03SKTPAG	Oily	GM03SKTPLY
All	GM03SKTPAL	Sensitive	GM03SKTPSE
Combination	GM03SKTPCM	Other	GM04SKTP99
Dry	GM03SKTPDR		

3.6.99 Skirt Type Code List

Code List Values for Skirt Type			
A-line	GM03SKRTAL	Pencil	GM03SKRTPE
Circular	GM03SKRTCI	Skort	GM03SKRTSK
Faux Wrap	GM03SKRTFW	Straight	GM03SKRTST
Flared	GM03SKRTFL	Tiered	GM03SKRTTI
Full	GM03SKRTFU	Wrap	GM03SKRTWR
Mermaid/Trumpet	GM03SKRTMT	Other	GM04SKRT99

3.6.100

Sleepwear Type Code List

Code List Values for Sleepwear Type			
Bridal	GM03SLPTBR	PJ Set	GM03SLPTPJ
Caftan	GM03SLPTCA	Robe	GM03SLPTRO
Chemise	GM03SLPTCH	Sleep Pant	GM03SLPTSP
Gown	GM03SLPTGW	Sleep Shirt	GM03SLPTSH
Loungewear	GM03SLPTLN	Sleep Short	GM03SLPTSO
Maternity	GM03SLPTMA	Sleep Top	GM03SLPTST
One Piece	GM03SLPTOP	Other	GM03SLPT99

3.6.101

Shoe Type Code List

Code List Values for Shoe Type			
Boots/Booties	GM03SETPBB	Pumps	GM03SETPPP
Clogs/Mules	GM03SETPCM	Sandals	GM03SETPSA
Flats	GM03SETPFL	Slippers	GM03SETPSL
Loafers	GM03SETPLM	Sneakers	GM03SETPSN
Oxfords	GM03SETPXF	Other	GM04SETP99

3.6.102

Skin Type Code List

Code List Values for Skin Type			
Aging	GM03SKTPAG	Oily	GM03SKTPLY
All	GM03SKTPAL	Sensitive	GM03SKTPSE
Combination	GM03SKTPCM	Other	GM04SKTP99
Dry	GM03SKTPDR		

3.6.103

Skirt Type Code List

Code List Values for Skirt Type			
A-line	GM03SKRTAL	Pencil	GM03SKRTPE
Circular	GM03SKRTCI	Skort	GM03SKRTSK
Faux Wrap	GM03SKRTFW	Straight	GM03SKRTST
Flared	GM03SKRTFL	Tiered	GM03SKRTTI
Full	GM03SKRTFU	Wrap	GM03SKRTWR
Mermaid/Trumpet	GM03SKRTMT	Other	GM04SKRT99

3.6.104

Sleepwear Type Code List

Code List Values for Sleepwear Type			
Bridal	GM03SLPTBR	PJ Set	GM03SLPTPJ
Caftan	GM03SLPTCA	Robe	GM03SLPTRO
Chemise	GM03SLPTCH	Sleep Pant	GM03SLPTSP
Gown	GM03SLPTGW	Sleep Shirt	GM03SLPTSH
Loungewear	GM03SLPTLN	Sleep Short	GM03SLPTSO
Maternity	GM03SLPTMA	Sleep Top	GM03SLPTST
One Piece	GM03SLPTOP	Other	GM03SLPT99

3.6.105 Sleeve Type Code List

Code List Values for Sleeve Type			
1/2 Sleeve	GM03SLVTHT	Roll-Tab (Long to elbow/short)	GM03SLVTRT
1/4 sleeve	GM03SLVTQS	Short	GM03SLVTST
3/4 Sleeve	GM03SLVTTT	Sleeveless	GM03SLVTS4
Cap	GM03SLVTCS	Spaghetti Strap	GM03SLVTSI
Elbow	GM03SLVTES	Other Sleeve Type*	GM04SLVT99
Long	GM03SLVTLO		
Roll-Tab (3/4 to short)	GM03SLVTTR		

* Requires use of PID05

3.6.106 Slip Type Code List

Code List Values for Slip Type			
Full	GM03SLTPFL	Other	GM03SLTP99
Half	GM03SLTPHA		

3.6.107 Social Certifications Code List

Code List Values for Social Certifications			
Fair Trade Certified	GM03SOCEFT	NMSDC with MBE Cert	GM03SOCENM
Fair Trade Certified Textile Standard	GM03SOCEFS	NGLCC with LGTBTE Cert	GM03SOCENG
RISE (or BSR Her, C.A.R.E, IFC Better Work)	GM03SOCERI	USPAACC	GM03SOCEUS
Fair for Life	GM03SOCEFL	Other	GM04SOCE99

3.6.108 Sole Type Code List

Code List Values for Sole Type	
Leather	GM03SOLTLS
Rubber	GM03SOLTRS
Synthetic	GM03SOLTSJ
Recycled	GM03SOLTRE
Natural Fiber	GM03SOLTNS
Other Sole Type*	GM04SOLT99

* Requires use of PID0

3.6.109

Special Embellishment Code List

Code List Values for Special Embellishment			
Beads	GM03SPEMBE	Logo	GM03SPEMLG
Belting	GM03SPEMBL	Metal	GM03SPEMME
Bows	GM03SPEMBW	Metal Ornament	GM03SPEMMR
Braiding	GM03SPEMBR	Nailheads	GM03SPEMNA
Broguing	GM03SPEMBG	Penny Keeper	GM03SPEMPK
Buckle(s)	GM03SPEMBU	Perforation	GM03SPEMPE
Chain	GM03SPEMCH	Piping	GM03SPEMPI
Contrast Stitching	GM03SPEMCS	Pleated	GM03SPEMPL
Crochet	GM03SPEMCR	Quilting	GM03SPEMQU
Cuff	GM03SPEMCF	Rhinestones	GM03SPEMRH
Cut-outs	GM03SPEMCU	Ruffles	GM03SPEMRU
Embroidery	GM03SPEMEM	Sequins	GM03SPEMSE
Feathers	GM03SPEMFE	Speed Lacing	GM03SPEMSL
Filigree	GM03SPEMFI	Stones	GM03SPEMSN
Flower	GM03SPEMFL	Studded	GM03SPEMST
Fringe	GM03SPEMFR	Tassels	GM03SPEMTA
Glitter	GM03SPEMGL	Tortoise	GM03SPEMTS
Grommets	GM03SPEMGR	Wood	GM03SPEMWD
Harness	GM03SPEMHA	Zipper	GM03SPEMZI
Jewels	GM03SPEMJE	Other	GM04SPEM99
Knotting	GM03SPEMKN		
Lace	GM03SPEMLA		

3.6.110

SPF Rating Code List

Code List Values for SPF Rating			
10	GM03SPFRRRA	50	GM03SPFRRE
15	GM03SPFRRB	60	GM03SPFRRF
30	GM03SPFRRRC	80	GM03SPFRRG
40	GM03SPFRRD	Other	GM04SPFR99

3.6.111

Sport Code List

Code List Values for Sport			
Badminton	ZZ03SPRTBD	Hunting	ZZ03SPRTHU
Baseball	ZZ03SPRTBA	Lacrosse	ZZ03SPRTLA
Basketball	ZZ03SPRTBK	Racing	ZZ03SPRTRA
Bocce Ball	ZZ03SPRTBB	Racquetball	ZZ03SPRTRC
Bowling	ZZ03SPRTBW	Rowing	ZZ03SPRTRW
Boxing/Martial Arts	ZZ03SPRTBM	Running	ZZ03SPRTRU
Climbing	ZZ03SPRTCL	Skiing	ZZ03SPRTSK
Cross Country	ZZ03SPRTCC	Soccer	ZZ03SPRTSC
Cross-Training	ZZ03SPRTCT	Softball	ZZ03SPRTSF
Cycling	ZZ03SPRTCY	Tennis	ZZ03SPRTE
Dance	ZZ03SPRTDA	Walking	ZZ03SPRTWK
Football	ZZ03SPRTFT	Water Skiing	ZZ03SPRTWA
Golf	ZZ03SPRTGF	Wrestling	ZZ03SPRTWR
Hiking	ZZ03SPRTHI	Yoga	ZZ03SPRTYG
Hockey	ZZ03SPRTHK	Other	ZZ04SPRT99

3.6.112

Strap Placement Code List

Code List Values for Strap Placement			
Centered Back	GM03STPLCB	Wide Set Back	GM03STPLWB
Centered Front	GM03STPLCF	Wide Set Front	GM03STPLWF
Centered Front and Back	GM03STPLCT	Other	GM03STPL99
Racerback	GM03STPLRA		

3.6.113

Supplemental Circularity Certifications Code List

Code List Values for Supplemental Circularity Certifications			
Reusable/Recyclable Product	GM03SUCCRR	Rentable Product	GM03SUCCRP
Take-Back Program	GM03SUCCTB	Other	GM04SUCC99
Archive Collection or Unworn Vintage	GM03SUCCAC		

3.6.114

Supplemental Corporate/Philanthropic Code List

Code List Values for Supplemental Corporate/Philanthropic			
Charitable Contribution X Every Purchase	GM03SCOPCC	Accreditation	GM03SCOPAC
One for One	GM03SCOPOO	Other	GM04SCOP99
Positive Luxury Butterfly Mark	GM03SCOPPL		

3.6.115

Supplemental Packaging Certifications Code List

Code List Values for Supplemental Packaging Certifications			
Reusable Packaging	GM03SPCERP	FSC Certified Paper/ Fiber-based packaging	GM03SPCEFS
Recyclable Packaging	GM03SPCERG	Reduced Packaging	GM03SPCERE
Packaging-Free	GM03SPCERF	Other	GM04SPCE99
Recycled Packaging Materials	GM03SPCERM		

3.6.116

Supplemental Raw Materials Certifications Code List

Code List Values for Supplemental Raw Materials Certifications			
Non-cert Upcycled Materials	GM03SRMCUM	PEFC (Programme for the endorsement of Forest Certification)	GM03SRMCPE
Non-cert Recycled Materials	GM03SRMCRM	Canopy GreenShirt Designation	GM03SRMCCG
Non-cert Vegan	GM03SRMCNV	Other	GM04SRMC99
Biodegradable Products Institute (BPI)	GM03SRMCBP		
Better Cotton	GM03SRMCBC		

3.6.117

Supplemental Traceability Programs Code List

Code List Values for Supplemental Traceability Programs			
Digital Passport	GM03SUTRDP	Traceability Program	GM03SUTRTP
Material Traceability	GM03SUTRMT	Other	GM04SUTR99
Open Hub Supply	GM03SUTROS		

3.6.118

Supply Type Code List

Code List Values for Supply Type			
Evergreen	ZZ03SUTYEV	Perennial	ZZ03SUTYPE
Made To Order	ZZ03SUTYMT	Seasonal with Limited Replenishment	ZZ03SUTYSL
Made to Stock	ZZ03SUTYMS	Other	ZZ04SUTY99

3.6.119

Support Level Code List

Code List Values for Support Level			
Comfort Support	GM03SULVCA	Maximum Support	GM03SULVMA
Full Support	GM03SULVFA	Medium Support	GM03SULVMB
Light Support	GM03SULVLA	Other	GM03SULV99

3.6.120

Sweater/Pullover Type Code List

Code List Values for Sweater/Pullover Type			
Babydoll	GM03SWPUBA	Hoodie	GM03SWPUHD
Blouse	GM03SWPUBL	Peasant	GM03SWPUPE
Box Top	GM03SWPUBT	Peplum	GM03SWPUPP
Bustier/Bra Top	GM03SWPUBB	Pullover	GM03SWPUPU
Button Front	GM03SWPUBF	Racerback	GM03SWPURA
Cami	GM03SWPUCA	Sweater	GM03SWPUSW
Camisole	GM03SWPUCM	Sweatshirt	GM03SWPUSS
Cardigan	GM03SWPUCR	Tank	GM03SWPUTA
Cocoon	GM03SWPUCC	T-Shirt	GM03SWPUTS
Dress Shirt	GM03SWPUDS	Tunic	GM03SWPUTU
Drop Waist	GM03SWPUDW	Vest	GM03SWPUVE
Faux Wrap	GM03SWPUFW	Wrap	GM03SWPUWR
Flyaway/Apron	GM03SWPUFA	Other	GM04SWPU99

3.6.121 Swim Bottom Type Code List

Code List Values for Swim Bottom Type			
Banded	GM03SWBTBA	Skirted	GM03SWBT SK
Boardshort	GM03SWBTBO	Tab Side	GM03SWBTTS
Brief	GM03SWBTBR	Tie Side	GM03SWBT TI
High Waist	GM03SWBTHW	Trunk	GM03SWBTTR
Hipster	GM03SWBTHI	Other	GM04SWBT99

3.6.122 Swim Cover Up Type Code List

Code List Values for Swim Cover Up Type			
Beach Shirt	GM03SWCTBS	Pareo	GM03SWCTPA
Bottom	GM03SWCTBO	Sun Dress	GM03SWCTSD
Caftan	GM03SWCTCA	Top	GM03SWCTTO
Jumpsuit/Romper	GM03SWCTJU	Tunic	GM03SWCTTU
Kimono	GM03SWCTKI	Other	GM04SWCT99
Maxi Dress	GM03SWCTMD		

3.6.123 Swim One-Piece Type Code List

Code List Values for Swim One-Piece Type			
Bandeau	GM03SWOTBA	Scoop Neck	GM03SWOTSC
Halter	GM03SWOTHA	Square Neck	GM03SWOTSQ
High Neck	GM03SWOTHN	Surplice	GM03SWOTSU
Monokini	GM03SWOTMO	Swim Dress	GM03SWOTSW
Off-Shoulder	GM03SWOTOF	Tank	GM03SWOTTA
One Shoulder	GM03SWOTON	Underwire	GM03SWOTUN
Plunge	GM03SWOTPL	V-neck	GM03SWOTVN
Rashguard	GM03SWOTRA	Other	GM04SWOT09

3.6.124 **Swim Top Type Code List**

Code List Values for Swim Top Type			
Bandeau	GM03SWTTBA	One Shoulder	GM03SWTTON
Bandini	GM03SWTTBN	Rashguard	GM03SWTTRA
Bralette	GM03SWTTBR	Tankini	GM03SWTTTA
Flutter	GM03SWTTFL	Triangle	GM03SWTTTR
Halter	GM03SWTTHA	Underwire	GM03SWTTUN
High Neck	GM03SWTTHN	Other	GM04SWTT99
Off Shoulder	GM03SWTTOF		

3.6.125 **Tableware Type**

Code List Values for Tableware Type			
Dinnerware	GM03TBLTDI	Glassware	GM03TBLTGL
Flatware	GM03TBLTFL	Other	GM04TBLT99

3.6.126

Third Detail Application Code List

Code List Values for Third Detail Application			
Applique	GM03TDAPAP	Logo Pin	GM03TDAPLP
Banded	GM03TDAPBA	Metallic Ink	GM03TDAPMI
Bling	GM03TDAPBL	Patch	GM03TDAPPA
Cut	GM03TDAPCU	Printed	GM03TDAPPR
Decal	GM03TDATDE	Printed Tackle Twill	GM03TDAPPT
Embossed	GM03TDAPEM	Raised Embroidery	GM03TDAPRE
Etched	GM03TDAPET	Reactive Glaze	GM03TDAPRG
Fabric Applique	GM03TDAPFA	Reflective Applique	GM03TDAPRA
Felt Applique	GM03TDAPFE	Reflective Screen Print	GM03TDAPRS
Flat Embroidered	GM03TDAPFM	Rhinestone	GM03TDAPRH
Foil	GM03TDAPFL	Screen Print	GM03TDAPSP
Glitter	GM03TDAPGL	Sequins	GM03TDAPSE
Hand Painted	GM03TDAPHP	Tackle Twill	GM03TDAPTT
Heat Seal	GM03TDAPHS	Woven	GM03TDAPWV
High Density Ink	GM03TDAPHD	Other	GM04TDAP99
Jacquard Knit	GM03TDAPJN		

3.6.127

Third Detail Placement Code List

Code List Values for Third Detail Placement			
All Over	GM03TDPLAA	Front Pocket	GM03TDPLFP
Back Bottom	GM03TDPLBB	Front Right	GM03TDPLFR
Back Center	GM03TDPLBC	Front Top	GM03TDPLFT
Back Left	GM03TDPLBL	Full Body	GM03TDPLFD
Back Pocket	GM03TDPLBP	Full Front	GM03TDPLFF
Back Right	GM03TDPLBR	Hem	GM03TDPLHE
Back Top	GM03TDPLBT	Left Leg	GM03TDPLLL
Bill	GM03TDPLBI	Left Sleeve	GM03TDPLLS
Collar	GM03TDPLCL	Leg	GM03TDPLLE
Cuff	GM03TDPLCU	Right Leg	GM03TDPLRL
Front Bottom	GM03TDPLFB	Right Sleeve	GM03TDPLRS
Front Center	GM03TDPLFC	Sleeve	GM03TDPLSL
Front Left	GM03TDPLFL	Other	GM04TDPL99

3.6.128

Third Detail Size Code List

Code List Values for Third Detail Size			
Large	GM03TDSZLG	Small	GM03TDSZSM
Medium	GM03TDSZMD	Other	GM04TDSZ99

3.6.129

Third Detail Type Code List

Code List Values for Third Detail Type			
Brand	GM03TDTPBR	Player Name	GM03TDTPPN
League	GM03TDTPLE	Script	GM03TDTPSC
Letter	GM03TDTPLT	Team	GM03TDTPTE
Mascot	GM03TDTPMA	Wordmark	GM03TDTPWM
Number	GM03TDTPNU	Other	GM04TDTP99
Patch	GM03TDTPPA		

3.6.130

Third Motif Theme Code List

Code List Values for Third Motif Theme			
Americana	GM03TMTTAM	Character	GM03TMTTCH
Animal	GM03TMTTAN	Other	GM04TMTT99

3.6.131

Toe Shape Code List

Code List Values for Toe Shape			
Almond	GM03TOESAL	Round	GM03TOESRD
Chisel	GM03TOESCH	Snip	GM03TOESSN
Oblique	GM03TOESOB	Square	GM03TOESSQ
Pointy	GM03TOESPY	Other	GM04TOES99

3.6.132

Toe Style Code List

Code List Values for Toe Style			
Apron Toe	GM03TOESAP	Split Toe	GM03TOESSP
Bike Toe	GM03TOESBI	Steel Toe	GM03TOESST
Cap Toe	GM03TOESCT	Tabi Toe	GM03TOESTA
Peep Toe	GM03TOESPT	Other	GM04TOEY99

3.6.133

Towel Type Code List

Code List Values for Towel Type			
Bath	GM03TOWLBA	Towel Set	GM03TOWLTS
Beach	GM03TOWLBE	Wash	GM03TOWLWA
Hand	GM03TOWLHA	Other	GM04TOWL99
Kitchen	GM03TOWLKI		

3.6.134

Waist Rise Code List

Code List Values for Waist Rise			
Classic	GM03WSDRCL	Mid	GM03WSDRMI
High	GM03WSDRHI	Other	GM04WSDR99
Low	GM03WSDRLW		

3.6.135 **Waistband Type Code List**

Code List Values for Waistband Type			
Band Roll	GM03WBTPBR	Knit	GM03WBTPKN
Belt Hook	GM03WBTPBH	Maternity	GM03WBTPMT
Drawstring	GM03WBTPDS	None	GM03WBTPNN
D-ring	GM03WBTPDR	Rigid	GM03WBTPRG
Expander	GM03WBTPEX	Self-Fabric Underwear	GM03WBTPSF
Full Elastic	GM03WBTPFE	Side Elastic	GM03WBTPSE
Half Elastic	GM03WBTPHE	Side Tab	GM03WBTPST
Hook and Loop	GM03WBTPVE	Stretch Elastic	GM03WBTPSR
Ino-Flex	GM03WBTPIF	Other	GM04WBTP99
Inside Adjustable	GM03WBTPIA		

3.6.136 **Watch Case Shape Code List**

Code List Values for Watch Case Shape			
Oval	JW03WACSV A	Square	JW03WACSSQ
Rectangular	JW03WACSRE	Other	JW04WACS99
Round	JW03WACSRN		

3.6.137 **Water Repellent Code List**

Code List Values for Water Repellent			
Waterproof	ZZ03WATRPF	Other	ZZ04WATR99
Water Resistant	ZZ03WATRRE		

3.7 Code List Instructions

Data Element 751 GS1 EDI Semi-Custom Product Description Code Matrix
Ten-character PID04 data structure is comprised of 4 parts
PART 1 - a 2-character Product Category Code GM - General Merchandise
PART 2 - a 2-character Format Option Code; codes used are '03' and '04'. If value '03', PID05 is not used If value '04', PID05 is required and carries a text description.
PART 3 - a 4-character Description Code
PART 4 - a 2-character Locator Placement Code
Example from list on MASTER worksheet:
Code GM03CLNTBL means General Merchandise, Collar-Neck Type is Ballet. PID05 is not used.
Code GM04CLNT99 means General Merchandise, Collar-Neck Type is 'Other'; PID05 is required and carries descriptive information about the collar type since the code does not provide sufficient information.
Structure of PID segment when PID05 is not used
PID01 - value of "S" denotes structured data follows
PID02 - value of "84"; denotes special specification
PID03 - value of "FD" denotes GS1 US
PID04 - code from Master table
Structure of PID segment when PID05 is used
PID01 - value of "X" denotes semi-structured data follows, includes PID05
PID02 - value of "84" denotes special specification
PID03 - value of "FD" denotes GS1 US
PID04 - code from table
PID05 - descriptive text

3.8 Recommended EDI Map for Core and Extended Product Information Exchange

Quick guide EDI data mapping for extended attributes pertaining to the EDI 832 Price/Sales Catalog.

Refer to the [GS1 US Trade Item Identification and Communication \(TIIC\) Guidelines for Electronic Data Interchange](#) for more information.

Attribute	EDI Data Mapping	Comments
Adhesive	YNQ at Detail 0450 YNQ01 – not used YNQ02 – ‘Y’ or ‘N’ YNQ10 – ‘ADHESIVE’	
Adjustable	YNQ at Detail 0450 YNQ01 – not used YNQ02 – ‘Y’ or ‘N’ YNQ10 – ‘ADJUSTABLE’	
Advertised Origin	PID at Detail 0700 PID01 – ‘S’ PID02 – ‘84’ PID03 – ‘FD’ PID04 – code from Advertised Origin table PID05 – Not used <u>Example: Made in U.S.A.</u> PID at Detail 0700 PID01 – ‘S’ PID02 – ‘84’ PID03 – ‘FD’ PID04 – GM03ADVOMU PID05 – GERMANY	For Advertise Origin made in another country not defined in the code list. <u>Example: GERMANY</u> PID01 – ‘X’ PID02 – ‘84’ PID03 – ‘FD’ PID04 – GM04BEDT9 PID05 – GERMANY
Adjustable Strap	PID at Detail 0700 PID01 – ‘S’ PID02 – ‘84’ PID03 – ‘FD’ PID04 – code from Adjustable Strap table PID05 – Not used	For Adjustable Strap not defined in the code list. <u>Example: MIDADJ</u> PID01 – ‘X’ PID02 – ‘84’ PID03 – ‘FD’ PID04 – GM03ADST99 PID05 – MIDADJ
Aerosol Product	PID at Detail 0700 PID01 – ‘F’ PID02 – ‘PFK’ PID03 – not used PID04 – not used PID05 – ‘Y’ or ‘N’	
Asthma/Allergy Certified	YNQ at Detail 0450 YNQ01 – not used YNQ02 – ‘Y’ or ‘N’ YNQ10 – ‘ASTHMA_ALLERGY_CERTIFIED’	



Attribute	EDI Data Mapping	Comments
Bag Type	PID at Detail 0700 PID01 - 'S' PID02 - '84' PID03 - 'FD' PID04 - code from Bag Type table PID05 - Not used	For Bag Type not defined in the code list. <u>Example:</u> <i>SACK</i> PID01 - 'X' PID02 - '84' PID03 - 'FD' PID04 - GM04BGST99 PID05 - SACK
Band Type	PID at Detail 0700 PID01 - 'S' PID02 - '84' PID03 - 'FD' PID04 - code from Band Type table PID05 - Not used	For Band Type not defined in the code list. <u>Example:</u> <i>ZULU</i> PID01 - 'X' PID02 - '84' PID03 - 'FD' PID04 - JW04WBND99 PID05 - ZULU
Beauty Area of Use	PID at Detail 0700 PID01 - 'S' PID02 - '84' PID03 - 'FD' PID04 - code from Beauty Area of Use table PID05 - Not used	For Beauty Area of Use not defined in the code list. <u>Example:</u> <i>EARS</i> PID01 - 'X' PID02 - '84' PID03 - 'FD' PID04 - GM04BAOU99 PID05 - EARS
Beauty Treatment Specialty	PID at Detail 0700 PID01 - 'S' PID02 - '84' PID03 - 'FD' PID04 - code from Beauty Treatment Specialty table PID05 - Not used	For Beauty Treatment Specialty not defined in the code list. <u>Example:</u> <i>BLOTCHINESS</i> PID01 - 'X' PID02 - '84' PID03 - 'FD' PID04 - GM04BTSP99 PID05 - BLOTCHINESS
Beauty Type	PID at Detail 0700 PID01 - 'S' PID02 - '84' PID03 - 'FD' PID04 - code from Beauty Type table PID05 - Not used	For Beauty Type not defined in the code list. <u>Example:</u> <i>DENTAL FLOSS</i> PID01 - 'X' PID02 - '84' PID03 - 'FD' PID04 - GM04BATYY99 PID05 - DENTAL FLOSS

Attribute	EDI Data Mapping	Comments
Bedding Size	PID at Detail 0700 PID01 - 'S' PID02 - '84' PID03 - 'FD' PID04 - code from Bedding Size table PID05 - Not used	For Bedding Size not defined in the code list. <u>Example:</u> <i>FLEX KING</i> PID01 - 'X' PID02 - '84' PID03 - 'FD' PID04 - GM04BDSZ99 PID05 - FLEX KING
Bedding Type	PID at Detail 0700 PID01 - 'S' PID02 - '84' PID03 - 'FD' PID04 - code from Bedding Type table PID05 - Not used	For Bedding Type not defined in the code list. <u>Example:</u> <i>QUILT</i> PID01 - 'X' PID02 - '84' PID03 - 'FD' PID04 - GM04BEDT9 PID05 - QUILT
Belt Type	PID at Detail 0700 PID01 - 'S' PID02 - '84' PID03 - 'FD' PID04 - code from Belt Type Table PID05 - Not used	For Belt Type not defined in the code list. <u>Example:</u> <i>LINK</i> PID01 - 'X' PID02 - '84' PID03 - 'FD' PID04 - GM04BETY99 PID05 - LINK
Bill Logo Application	PID at Detail 0700 PID01 - 'S' PID02 - '84' PID03 - 'FD' PID04 - code from Bill Logo table PID05 - Not used	For Bill Logo Application not defined in the code list. <u>Example:</u> <i>STAMPED</i> PID01 - 'X' PID02 - '84' PID03 - 'FD' PID04 - GM04BILL99 PID05 - STAMPED
Bill Type	PID at Detail 0700 PID01 - 'S' PID02 - '84' PID03 - 'FD' PID04 - code from Bill Type table PID05 - Not used	For Bill Type not defined in the code list. <u>Example:</u> <i>TRUCKER</i> PID01 - 'X' PID02 - '84' PID03 - 'FD' PID04 - GM04BILT99 PID05 - TRUCKER
Boot Leg Circumference	MEA at Detail 0800 MEA01 - 'PD' MEA02 - 'LS' MEA03 - measurement value MEA04 - unit of measure code	



Attribute	EDI Data Mapping	Comments
Boot Shaft Height	MEA at Detail 0800 MEA01 – 'PD' MEA02 – 'TS' MEA03 – measurement value MEA04 – unit of measure code	
Boot Shaft Type	PID at Detail 0700 PID01 – 'S' PID02 – '84' PID03 – 'FD' PID04 – code from Boot Shaft Type table PID05 – Not used	For Boot Shaft Type not defined in the code list. <u>Example:</u> THIGH HIGH PID01 – 'X' PID02 – '84' PID03 – 'FD' PID04 – V PID05 – THIGH HIGH
Boxed for Gift Giving	YNQ at Detail 0450 YNQ01 – not used YNQ02 – 'Y' or 'N' YNQ10 – 'BOXED_FOR_GIVING'	
Bra Band Type	PID at Detail 0700 PID01 – 'S' PID02 – '84' PID03 – 'FD' PID04 – code from Bra Band Type table PID05 – Not used	For Bra Band Type not defined in the code list. <u>Example:</u> CONTINUOUS PID01 – 'S' PID02 – '84' PID03 – 'FD' PID04 – GM03BRBN99 PID05 – CONTINUOUS
Bra Bust Type	PID at Detail 0700 PID01 – 'S' PID02 – '84' PID03 – 'FD' PID04 – code from Bra Bust Type table PID05 – Not used	For Bra Bust Type not defined in the code list. <u>Example:</u> SLIGHT PID01 – 'S' PID02 – '84' PID03 – 'FD' PID04 – GM03BRBT99 PID05 – SLIGHT
Bra Cup Coverage	PID at Detail 0700 PID01 – 'S' PID02 – '84' PID03 – 'FD' PID04 – code from Bra Cup Coverage table PID05 – Not used	For Bra Cup Coverage not defined in the code list. <u>Example:</u> COMPLETE PID01 – 'S' PID02 – '84' PID03 – 'FD' PID04 – GM03BRCC99 PID05 – COMPLETE



Attribute	EDI Data Mapping	Comments
Bra Cup Type	PID at Detail 0700 PID01 - 'S' PID02 - '84' PID03 - 'FD' PID04 - code from Bra Cup Type table PID05 - Not used	For Bra Cup Type not defined in the code list. <u>Example:</u> <i>POINTED</i> PID01 - 'S' PID02 - '84' PID03 - 'FD' PID04 - GM03BRCT99 PID05 - POINTED
Bra Impact Level	PID at Detail 0700 PID01 - 'S' PID02 - '84' PID03 - 'FD' PID04 - code from Impact Level table PID05 - Not used	For Impact Level not defined in the code list. <u>Example:</u> <i>SPARTAN</i> PID01 - 'X' PID02 - '84' PID03 - 'FD' PID04 - GM03BRIL99 PID05 - SPARTAN
Bra Padding	PID at Detail 0700 PID01 - 'S' PID02 - '84' PID03 - 'FD' PID04 - code from Bra Padding table PID05 - Not used	For Bra Padding not defined in the code list. <u>Example:</u> <i>AIR</i> PID01 - 'S' PID02 - '84' PID03 - 'FD' PID04 - GM03BRPD99 PID05 - AIR
Bra Specialty Type	PID at Detail 0700 PID01 - 'S' PID02 - '84' PID03 - 'FD' PID04 - code from Bra Specialty Type table PID05 - Not used	For Bra Specialty Type not defined in the code list. <u>Example:</u> <i>PRO ATHLETE</i> PID01 - 'X' PID02 - '84' PID03 - 'FD' PID04 - GM03BRTY99 PID05 - PRO ATHLETE
Bra Type	PID at Detail 0700 PID01 - 'S' PID02 - '84' PID03 - 'FD' PID04 - code from Bra Type table PID05 - Not used	For Bra Type not defined in the code list. <u>Example:</u> <i>INVISIBLE</i> PID01 - 'S' PID02 - '84' PID03 - 'FD' PID04 - GM03BRTY99 PID05 - INVISIBLE
Bra Underwire	YNQ at Detail 0450 YNQ01 - not used YNQ02 - 'Y' or 'N' YNQ10 - 'BRA_UNDERWIRE'	



Attribute	EDI Data Mapping	Comments
Bracelet Type	PID at Detail 0700 PID01 - 'S' PID02 - '84' PID03 - 'FD' PID04 - code from Bracelet Type table PID05 - Not used	For Bracelet Type not defined in the code list. <u>Example:</u> <i>STATEMENT</i> PID01 - 'S' PID02 - '84' PID03 - 'FD' PID04 - JW04BRTT99 PID05 - STATEMENT
Brand Name	PID at Detail 0700 PID01 - 'F' PID02 - 'BND' PID03 - not used PID04 - not used PID05 - brand name	
Care Information	LM/LQ Loop at Detail 3300 LM01 - 'VI' LQ01 - not used LQ02 'MMINSCAR' PID01 - 'S' PID02 - not used PID03 - 'VI' PID04 - 'CI' MTX01 - not used MTX02 - care information	
Care Instructions Code	PID at Detail 0700 PID01 - 'S' PID02 - '84' PID03 - 'FD' PID04 - code from Care Instructions Code table PID05 - Not used	For Care Instructions Code not defined in the code list. <u>Example:</u> <i>WASH INSIDE OUT</i> PID01 - 'X' PID02 - '84' PID03 - 'FD' PID04 - GM04CAIN99 PID05 - WASH INSIDE OUT
Circularity Certifications	PID at Detail 0700 PID01 - 'S' PID02 - '84' PID03 - 'FD' PID04 - GM03CICECC PID05 - Not used	For Circularity Certifications not defined in the code list. <u>Example:</u> <i>OTHER</i> PID01 - 'X' PID02 - '84' PID03 - 'FD' PID04 - GM04CICE99 PID05 - OTHER

Attribute	EDI Data Mapping	Comments
Closure	PID at Detail 0700 PID01 - 'S' PID02 - '84' PID03 - 'FD' PID04 - code from Closure table PID05 - Not used; <i>see Comments</i> <u>Example: Buckle</u> PID at Detail 0700 PID01 - 'S' PID02 - '84' PID03 - 'FD' PID04 - GM03CLOSBU PID05 - Not used	For Closure not defined in the code list. <u>Example: DOUBLE BUTTON</u> PID01 - 'X' PID02 - '84' PID03 - 'FD' PID04 - GM04CLOS99 PID05- DOUBLE BUTTON
Coat/Jacket Type	PID at Detail 0700 PID01 - 'S' PID02 - '84' PID03 - 'FD' PID04 - code from Coat/Jacket Type table PID05 - Not used	For Coat/Jacket Type not defined in the code list. <u>Example: COCOON</u> PID01 - 'X' PID02 - '84' PID03 - 'FD' PID04 - M04COAT99 PID05 - COCOON
Chemical Certifications	PID at Detail 0700 PID01 - 'S' PID02 - '84' PID03 - 'FD' PID04 - code from Chemical Certifications table PID05 - Not used	For Chemical Certifications Type not defined in the code list. <u>Example: LEAD</u> PID01 - 'X' PID02 - '84' PID03 - 'FD' PID04 - GM04CHCE99 PID05 - LEAD
Collar Type	PID at Detail 0700 PID01 - 'S' PID02 - '84' PID03 - 'FD' PID04 - code from Collar Type table PID05 - Not used; <i>see Comments</i> <u>Example: Button Down</u> PID at Detail 0700 PID01 - 'S' PID02 - '84' PID03 - 'FD' PID04 - GM03CLNTBD PID05 - Not used	For Collar not defined in the code list. <u>Example: SNAP TWIST</u> PID01 - 'X' PID02 - '84' PID03 - 'FD' PID04 - GM04CLNT99 PID05 - SNAP TWIST



Attribute	EDI Data Mapping	Comments
Color Code - GS1 US	LIN Segment at Detail 0100 LIN01-Assigned ID Pick an iteration of data element 235/234 pair. LIN04-30 (even) – code CM LIN05-31 (odd) – GS1 US Color Code	<u>Example:</u> LIN*1*UP*061414100014*CM*100
Color Description	PID at Detail 0700 PID01 – 'F' PID02 – '73' PID05 – color description	
Color Extended Description	PID at Detail 0700 PID01 – 'F' PID02 – '73' PID03- 'VI' PID04- 'ED' PID05 – extended color description	<u>Example:</u> PID*F*73*VI*ED*SEA FOAM GREEN
Conference	PID at Detail 0700 PID01 – 'S' PID02 – '84' PID03 – 'FD' PID04 – code from Conference table PID05 – Not used	For Conference not defined in the code list. <u>Example: DIVISION 1</u> PID01 – 'X' PID02 – '84' PID03 – 'FD' PID04 – Z04CONF99 PID05 – DIVISION 1
Consumer Available Date	DTM at Detail 0300 DTM01 – '614' DTM02 – CCYYMMDD value	
Consumer Item Depth	MEA at Detail 0800 MEA01 – PD MEA02 – DP MEA03 – measurement value MEA04 – unit of measure	
Consumer Item Height	MEA at Detail 0800 MEA01 – PD MEA02 – HT MEA03 – measurement value MEA04 – unit of measure	
Consumer Item Length	MEA at Detail 0800 MEA01 – PD MEA02 – LN MEA03 – measurement value MEA04 – unit of measure	



Attribute	EDI Data Mapping	Comments
Consumer Item Weight	MEA at Detail 0800 MEA01 – PD MEA02 – WT MEA03 – measurement value MEA04 – unit of measure	
Consumer Item Width	MEA at Detail 0800 MEA01 – PD MEA02 – WD MEA03 – measurement value MEA04 – unit of measure	
Consumer Life Stage	PID at Detail 0700 PID01 – 'S' PID02 – '84' PID03 – 'FD' PID04 – code from Consumer Lifestage table PID05 – Not used	For Consumer Lifestage not defined in the code list. <u>Example:</u> <i>MILLENNIAL</i> PID01 – 'X' PID02 – '84' PID03 – 'FD' PID04 – M04CNLS99 PID05 – MILLENNIAL
Consumer Package Depth	G55 at Detail 1680 G5509 – depth value G5510 – unit of measure	Measurement is for the consumer item as packaged.
Consumer Package Gross Weight	G55 at Detail 1680 G5523 – weight of the packaged item G5524 – 'G' G5525 – unit of measure	Measurement is for the consumer item as packaged.
Consumer Package Height	G55 at Detail 1680 G5505 – height value G5506 – unit of measure	Measurement is for the consumer item as packaged.
Consumer Package Width	G55 at Detail 1680 G5507 – width value G5508 – unit of measure	Measurement is for the consumer item as packaged.
Consumer Product Capacity or Volume	G55 at Detail 1680 G5514 – value G5515 – unit of measure	
Consumer Product Safety Improvement Act (CPSIA) Flag	YNQ at Detail 0450 YNQ01 – not used YNQ02 – 'Y' or 'N' YNQ10 – 'CPSIA'	
Consumer Quantity of Units In Consumer Package	G55 at Detail 1680 G5513 – value	

Attribute	EDI Data Mapping	Comments
Control Level	PID at Detail 0700 PID01 - 'S' PID02 - '84' PID03 - 'FD' PID04 - code from Control Level table PID05 - Not used	For Finish not defined in the code list. <u>Example:</u> <i>OUT OF</i> PID01 - 'X' PID02 - '84' PID03 - 'FD' PID04 - +++++ PID05 - OUT OF
Convertible	YNQ at Detail 0450 YNQ01 - not used YNQ02 - 'Y' or 'N' YNQ10 - 'CONVERTIBLE'	
Cookware Type	PID at Detail 0700 PID01 - 'S' PID02 - '84' PID03 - 'FD' PID04 - code from Cookware Type table PID05 - Not used	For Cookware Type not defined in the code list. <u>Example:</u> <i>SAUCIER</i> PID01 - 'X' PID02 - '84' PID03 - 'FD' PID04 - GM04COOK99 PID05 - SAUCIER
Corporate/Philanthropic Certifications	PID at Detail 0700 PID01 - 'S' PID02 - '84' PID03 - 'FD' PID04 - code from Corporate/Social Certifications Code list PID05 - Not used	For Corporate/Philanthropic Certifications not defined in the code list. <u>Example:</u> <i>OTHER</i> PID01 - 'X' PID02 - '84' PID03 - 'FD' PID04 - GM04COPH99 PID05 - OTHER
Country of Origin	LIN at Detail 0100 Pick an iteration of data element 235/234 pair. LIN02-30 (even) - data element 235 with code value of 'CH'; LIN03-31 (odd) - data element 234 w/ ISO code	Use 3-character ISO country code. For more than one country, leave a space between ISO country codes in the text stream.
Covered	YNQ at Detail 0450 YNQ01 - not used YNQ02 - 'Y' or 'N' YNQ10 - 'COVERED'	
Crown	PID at Detail 0700 PID01 - 'S' PID02 - '84' PID03 - 'FD' PID04 - code from Crown Type table PID05 - Not used	For Crown not defined in the code list. <u>Example:</u> <i>HALF</i> PID01 - 'X' PID02 - '84' PID03 - 'FD' PID04 - GM04CRWN99 PID05 - HALF

Attribute	EDI Data Mapping	Comments
Cuff Type	PID at Detail 0700 PID01 - 'S' PID02 - '84' PID03 - 'FD' PID04 - code from Cuff Type table PID05 - Not used	For Cuff Type not defined in the code list. <u>Example:</u> <i>CONVERTIBLE</i> PID01 - 'X' PID02 - '84' PID03 - 'FD' PID04 - GM04CFTP99 PID05 - CONVERTIBLE
Detachable Strap	YNQ at Detail 0450 YNQ01 - not used YNQ02 - 'Y' or 'N' YNQ10 - 'DETACHABLE_STRAP'	
Dinnerware Category	PID at Detail 0700 PID01 - 'S' PID02 - '84' PID03 - 'FD' PID04 - code from Dinnerware Category table PID05 - Not used	For Dinnerware Category not defined in the code list. <u>Example:</u> <i>PICNIC</i> PID01 - 'X' PID02 - '84' PID03 - 'FD' PID04 - GM04DNRC99 PID05 - PICNIC
Discontinue Date	DTM at Detail 0300 DTM01 - '036' DTM02 - CCYYMMDD value	
Dishwasher Safe	YNQ at Detail 0450 YNQ01 - not used YNQ02 - 'Y' or 'N' YNQ10 - 'DISHWASHER_SAFE'	
Does Not Contain	PID at Detail 0700 PID01 - 'X' PID02 - '84' PID03 - 'AS' PID04 - 'DOESNOTCONTAIN' PID05 - text value	
Dress Type	PID at Detail 0700 PID01 - 'S' PID02 - '84' PID03 - 'FD' PID04 - code from Dress Type table PID05 - Not used	For Dress Type not defined in the code list. <u>Example:</u> <i>MAXI</i> PID01 - 'X' PID02 - '84' PID03 - 'FD' PID04 - GM04DRTP99 PID05 - MAXI
Earring Drop	MEA at Detail 0800 MEA01 - 'PS' MEA02 - 'F6' MEA03 - measurement value MEA04 - unit of measure code	

Attribute	EDI Data Mapping	Comments
Earring Type	PID at Detail 0700 PID01 - 'S' PID02 - '84' PID03 - 'FD' PID04 - code from Earring Type table PID05 - Not used	For Earring Type not defined in the code list. <u>Example:</u> <i>CRAWLER</i> PID01 - 'X' PID02 - '84' PID03 - 'FD' PID04 - JW04EATP99 PID05 - CRAWLER
Eyewear Type	PID at Detail 0700 PID01 - 'S' PID02 - '84' PID03 - 'FD' PID04 - code from Eyewear Type table PID05 - Not used	For Eyewear Type not defined in the code list. <u>Example:</u> <i>MOVIE STAR</i> PID01 - 'X' PID02 - '84' PID03 - 'FD' PID04 - GM04EYES99 PID05 - MOVIE STAR
Fabric or Material	PID at Detail 0700 PID01 - 'S' PID02 - '84' PID03 - 'FD' PID04 - code from Fabric or Material table PID05 - Not used	For Fabric or Material is not defined in the code list. <u>Example:</u> <i>DAZZLE</i> PID01 - 'X' PID02 - '84' PID03 - 'FD' PID04 - XXXX PID05 - DAZZLE
Fabric or Material Description	PID at Detail 0700 PID01 - 'F' PID02 - '92' PID03 - not used PID04 - not used PID05 - fabric description value	
Faux Fur	YNQ at Detail 0450 YNQ01 - not used YNQ02 - 'Y' or 'N' YNQ10 - 'FAUXFUR'	
Features – Benefits - Marketing Message	LM/LQ Loop at Detail 3300 LM01 - 'VI' LQ01 - not used LQ02 - 'MMADVFEA' PID01 - 'S' PID02 - not used PID03 - 'VI' PID04 - 'SK' MTX01 - not used MTX02 - message text	

Attribute	EDI Data Mapping	Comments
Fiber	PID at Detail 0700 PID01 - 'S' PID02 - '84' PID03 - 'FD' PID04 - code from Fiber table PID05 - Not used	For Fiber not defined in the code list. <u>Example:</u> <i>MOOSE</i> PID01 - 'X' PID02 - '84' PID03 - 'FD' PID04 - XXXXX PID05 - MOOSE
Fill Material	PID at Detail 0700 PID01 - 'S' PID02 - '84' PID03 - 'FD' PID04 - code from Fill Material table PID05 - Not used	For Fill Material not defined in the code list. <u>Example:</u> <i>HORSEHAIR</i> PID01 - 'X' PID02 - '84' PID03 - 'FD' PID04 - GM04FILM99 PID05 - HORSEHAIR
Finish	PID at Detail 0700 PID01 - 'S' PID02 - '84' PID03 - 'FD' PID04 - code from Finish table PID05 - Not used	For Finish not defined in the code list. <u>Example:</u> <i>ROUGH HEWN</i> PID01 - 'X' PID02 - '84' PID03 - 'FD' PID04 - GM04FNH99 PID05 - ROUGH HEWN
First Available Ship Date	DTM at Detail 0300 DTM01 - '018' DTM02 - CCYMMDD value	
First Order Date	DTM at Detail 0300 DTM01 - '092' DTM02 - CCYMMDD value	
Fit	PID at Detail 0700 PID01 - 'S' PID02 - '84' PID03 - 'FD' PID04 - code from Fit table PID05 - Not used	For Fit not defined in the code list. <u>Example:</u> <i>ATHLETIC</i> PID01 - 'X' PID02 - '84' PID03 - 'FD' PID04 - GM04FITT99 PID05 - ATHLETIC
Flatware Type	PID at Detail 0700 PID01 - 'S' PID02 - '84' PID03 - 'FD' PID04 - code from Flatware Type table PID05 - Not used	For Flatware Type not defined in the code list. <u>Example:</u> <i>PICKLE FORK</i> PID01 - 'X' PID02 - '84' PID03 - 'FD' PID04 - GM04FLAT99 PID05 - PICKLE FORK

Attribute	EDI Data Mapping	Comments
Formulation	PID at Detail 0700 PID01 - 'S' PID02 - '84' PID03 - 'FD' PID04 - code from Formulation table PID05 - Not used	For Formulation not defined in the code list. <u>Example: EMULSION</u> PID01 - 'X' PID02 - '84' PID03 - 'FD' PID04 - GM04FORM99 PID05 - EMULSION
Full Product Name	PID at Detail 0700 PID01 - 'X' PID02 - '08' Pid03 - 'AS' PID04 - 'ED' PID05 - Full product name	
Fur Animal Name	PID at Detail 0700 PID01 - 'S' PID02 - '84' PID03 - 'FD' PID04 - code from Fur Animal Name table PID05 - Not used; <i>see Comments</i> <u>Example: Fox</u> PID at Detail 0700 PID01 - 'S' PID02 - '84' PID03 - 'FD' PID04 - GM03FANMFX PID05 - Not used	For Fur Animal Name not defined in the code list. <u>Example: WATER BUFFALO</u> PID01 - 'X' PID02 - '84' PID03 - 'FD' PID04 - 'GM04FANM99' PID05 - WATER BUFFALO
Fur Country of Origin	LIN at Detail 0100 Pick an iteration of data element 235/234 pair. LIN04-30 (even) - data element 235 with code value of 'CZ'; LIN03-31 (odd) - data element 234 w/ brand name	Use 3-character ISO country code. For more than one country, leave a space between ISO country codes in the text stream.
Fur Treatment	PID at Detail 0700 PID01 - 'S' PID02 - '84' PID03 - 'FD' PID04 - code from Fur Treatment table PID05 - Not used; <i>see Comments</i> <u>Example: Dyed</u> PID at Detail 0700 PID01 - 'S' PID02 - '84' PID03 - 'FD' PID04 - GM03FTMTDY PID05 - Not used	

Attribute	EDI Data Mapping	Comments
Gauge	PID at Detail 0700 PID01 – 'S' PID02 – '84' PID03 – 'FD' PID04 – code from Gauge table PID05 – Not used	For Gauge not defined in the code list. <u>Example:</u> <i>DOUBLE FINE</i> PID01 – 'X' PID02 – '84' PID03 – 'FD' PID04 – GM04GAUG99 PID05 – DOUBLE FINE
Gender	PID at Detail 0700 PID01 – 'S' PID02 – '84' PID03 – 'FD' PID04 – code from Gender table PID05 – Not used	For Gender not defined in the code list. <u>Example:</u> <i>AGENDER</i> PID01 – 'X' PID02 – '84' PID03 – 'FD' PID04 – ZZ04GEND99 PID05 – AGENDER
Global Product Classification (GPC)	PID at Detail 0700 PID01- 'S' PID02- '84' PID03- 'FD' PID04- 'ZZ04PCGP99' PID05- GPC code from the GS1 GPC table	See GS1 GPC Tables
Glove Type	PID at Detail 0700 PID01 – 'S' PID02 – '84' PID03 – 'FD' PID04 – code from Glove Type Table PID05 – Not used	For Glove Type not defined in the code list. <u>Example:</u> <i>EVENING</i> PID01 – 'X' PID02 – '84' PID03 – 'FD' PID04 – GM04GLTY99 PID05 – EVENING
Gold Karat	MEA at Detail 0800 MEA01 – 'PS' MEA02 – 'GD' MEA03 – measurement value MEA04 – 'CD'	
GTIN	LIN SEGMENT at Detail 0100 LIN01 – Assigned ID Pick an iteration of data element 235/234 pair from LIN04-LIN30 Send UP followed by 12-digit UPC GTIN or Send EN followed by 13-digit EAN GTIN or Send EO followed by 8-digit GTIN or Send UK followed by 14-digit GTIN	Example: LIN*1*SM*30902
Hand Painted	YNQ at Detail 0450 YNQ01 – not used YNQ02 – 'Y' or 'N' YNQ10 – 'HAND_PAINTED'	

Attribute	EDI Data Mapping	Comments
Handbag Shoulder Drop	MEA at Detail 0800 MEA01 – ‘PS’ MEA02 – ‘F6’ MEA03 – measurement value MEA04 –unit of measure	
Handle Strap	YNQ at Detail 0450 YNQ01 – not used YNQ02 – ‘Y’ or ‘N’ YNQ10 – ‘HANDLE_STRAP’	
Handmade	YNQ at Detail 0450 YNQ01 – not used YNQ02 – ‘Y’ or ‘N’ YNQ10 – ‘HANDMADE’	
Harmonized Tariff Schedule Code	TC2 at Detail 1650 TC201-‘A’ TC202 – code value	
Hat Type	PID at Detail 0700 PID01 – ‘S’ PID02 – ‘84’ PID03 – ‘FD’ PID04 – code from Hat Type table PID05 – Not used	For Hat Type not defined in the code list. <u>Example:</u> <i>CHURCH</i> PID01 – ‘X’ PID02 – ‘84’ PID03 – ‘FD’ PID04 – GM04HATS99 PID05 – CHURCH
Hazardous Material (HM) Class Code, Hazardous Material Description	TD4 at Detail 1100 TD401 – select from X12 code list, if relevant TD402 – select from code list, if relevant TD403 – HM Class Code TD404 – HM Description value	
Heel Height	MEA at Detail 0800 MEA01 – ‘PD’ MEA02 – ‘5F’ MEA03 – measurement value MEA04 – unit of measure code	
Heel Height Range	PID at Detail 0700 PID01 – ‘S’ PID02 – ‘84’ PID03 – ‘FD’ PID04 – code from Heel Height Range table PID05 – Not used	For Heel Height Range not defined in the code list. <u>Example:</u> <i>ULTRA 4 INCHES ></i> PID01 – ‘X’ PID02 – ‘84’ PID03 – ‘FD’ PID04 – GM04HLHT99 PID05 – ULTRA 4 INCHES >



Attribute	EDI Data Mapping	Comments
Heel Material	PID at Detail 0700 PID01 - 'S' PID02 - '84' PID03 - 'FD' PID04 - code from Heel Material table PID05 - Not used	For Heel Material not defined in the code list. <u>Example:</u> <i>ACRYLIC</i> PID01 - 'X' PID02 - '84' PID03 - 'FD' PID04 - GM04HLMT99 PID05 - ACRYLIC
Heel Type	PID at Detail 0700 PID01 - 'S' PID02 - '84' PID03 - 'FD' PID04 - code from Heel Type table PID05 - Not used	For Heel Type not defined in the code list. <u>Example:</u> <i>SPOOL</i> PID01 - 'X' PID02 - '84' PID03 - 'FD' PID04 - GM04HLTY99 PID05 - SPOOL
Holiday/Event	PID at Detail 0700 PID01 - 'S' PID02 - '84' PID03 - 'FD' PID04 - code from Holiday/Event table PID05 - Not used	For Holiday/Event not defined in the code list. <u>Example:</u> <i>FESTIVUS</i> PID01 - 'X' PID02 - '84' PID03 - 'FD' PID04 - ZZ04HOEV99 PID05 - FESTIVUS
Hooded	YNQ at Detail 0450 YNQ01 - not used YNQ02 - 'Y' or 'N' YNQ10 - 'HOODED'	
Hosiery/Sock Type	PID at Detail 0700 PID01 - 'S' PID02 - '84' PID03 - 'FD' PID04 - code from Hosiery/Sock Type table PID05 - Not used	For Hosiery/Sock Type not defined in the code list. <u>Example:</u> <i>TOE SOCKS</i> PID01 - 'X' PID02 - '84' PID03 - 'FD' PID04 - GM04HOSO99 PID05 - TOE SOCKS
Hypoallergenic	YNQ at Detail 0450 YNQ01 - not used YNQ02 - 'Y' or 'N' YNQ10 - 'HYPOALLERGENIC'	
Ingredients	PID at Detail 0700 PID01 - 'F' PID02 - 'ING' PID03 - not used PID04 - not used PID05 - list of ingredients	



Attribute	EDI Data Mapping	Comments
Inner Pack Quantity	Case: G3917 - Pack G3929 - Inner pack Consumer: G5513 - Pack G5532 - Inner pack	
Insulated	YNQ at Detail 0450 YNQ01 - not used YNQ02 - 'Y' or 'N' YNQ10 - 'INSULATED'	
Jewelry Sets	PID at Detail 0700 PID01 - 'S' PID02 - '84' PID03 - 'FD' PID04 - code from Jewelry Sets table PID05 - Not used	For Jewelry Sets not defined in the code list. <u>Example:</u> TOE/HAND PID01 - 'X' PID02 - '84' PID03 - 'FD' PID04 - JW04JWST99 PID05 - TOE/HAND
Jewelry Type	PID at Detail 0700 PID01 - 'S' PID02 - '84' PID03 - 'FD' PID04 - code from Jewelry Type table PID05 - Not used	For Jewelry Type not defined in the code list. <u>Example:</u> CHILDREN'S PID01 - 'X' PID02 - '84' PID03 - 'FD' PID04 - JW04JWLT99 PID05 - CHILDREN'S
Key-Active Ingredients	PID at Detail 0700 PID01 - 'X' PID02 - '84' PID03 - 'AS' PID04 - 'KEYACTIVEING' PID05 - description value	
Knit Type	PID at Detail 0700 PID01 - 'S' PID02 - '84' PID03 - 'FD' PID04 - code from Knit Type table PID05 - Not used	For Knit Type not defined in the code list. <u>Example:</u> TUFT PID01 - 'X' PID02 - '84' PID03 - 'FD' PID04 - GM04KNIT99 PID05 - TUFT
Laser Cut	YNQ at Detail 0450 YNQ01 - not used YNQ02 - 'Y' or 'N' YNQ10 - 'LASER CUT'	



Attribute	EDI Data Mapping	Comments
Lead Time	LDT at Detail 1400 LDT01 - 'AF' LDT02 - number of days LDT03 - 'DA' - calendar days	
League	PID at Detail 0700 PID01 - 'S' PID02 - '84' PID03 - 'FD' PID04 - code from League table PID05 - Not used	For League not defined in the code list. <u>Example:</u> <i>RECREATION</i> PID01 - 'X' PID02 - '84' PID03 - 'FD' PID04 - ZZ04LEAG99 PID05 - RECREATION
Leather Animal Name	PID at Detail 0700 PID01 - 'S' PID02 - '84' PID03 - 'FD' PID04 - code from Leg Type table PID05 - Not used	For Leather Animal Name not defined in the code list. <u>Example:</u> <i>HORSE</i> PID01 - 'X' PID02 - '84' PID03 - 'FD' PID04 - GM04LEAN99 PID05 - HORSE
Leg Type	PID at Detail 0700 PID01 - 'S' PID02 - '84' PID03 - 'FD' PID04 - code from Leg Type table PID05 - Not used	For Leg Type not defined in the code list. <u>Example:</u> <i>STOVEPIPE</i> PID01 - 'X' PID02 - '84' PID03 - 'FD' PID04 - GM04LGTY99 PID05 - STOVEPIPE
Length Description	PID at Detail 0700 PID01 - 'S' PID02 - '84' PID03 - 'FD' PID04 - code from Length Description table PID05 - Not used	For Length not defined in the code list. <u>Example:</u> <i>MEDIUM BREAK</i> PID01 - 'X' PID02 - '84' PID03 - 'FD' PID04 - GM04LNTH99 PID05 - MEDIUM BREAK
Lined	PID at Detail 0700 PID01 - 'S' PID02 - '84' PID03 - 'FD' PID04 - code from Lined table PID05 - Not used	For Lined value not defined in the code list. <u>Example:</u> <i>QUARTER LINED</i> PID01 - 'X' PID02 - '84' PID03 - 'FD' PID04 - GM04LIND99 PID05 - QUARTER LINED

Attribute	EDI Data Mapping	Comments
Lining Material	PID at Detail 0700 PID01 - 'S' PID02 - '84' PID03 - 'FD' PID04 - code from Lining Material table PID05 - Not used; <i>see Comments</i> <u>Example: Fleece</u> PID at Detail 0700 PID01 - 'S' PID02 - '84' PID03 - 'FD' PID04 - GM03LIMTFC PID05 - Not used	For Lining Material not defined in the code list. <u>Example: Paper</u> PID01 - 'X' PID02 - '84' PID03 - 'FD' PID04 - GM04LIMT99 PID05 - Paper
Marked Retail Price	YNQ at Detail 0450 YNQ01 - not used YNQ02 - 'Y' or 'N' YNQ10 - 'MARKED_RETAIL_PRICE'	Note the marked price is shown in the G5521
Material Country of Origin	PID at Detail 0700 PID01 - 'X' PID02 - '84' PID03 - 'FD' PID04 - 'GM04MC0099' PID05 - ISO Country Codes (if more than one, separate with a space)	Example: PID*X*84*FD*GM04MCO099*USA CAN~
Maternity	YNQ at Detail 0450 YNQ01 - not used YNQ02 - 'Y' or 'N' YNQ10 - 'MATERNITY'	
Metal	PID at Detail 0700 PID01 - 'S' PID02 - '84' PID03 - 'FD' PID04 - code from Metal table PID05 - Not used	For Metal not defined in the code list. <u>Example: TIN</u> PID01 - 'X' PID02 - '84' PID03 - 'FD' PID04 - JW04METL99 PID05 - TIN
Metal Composition	PID at Detail 0700 PID01 - 'S' PID02 - '84' PID03 - 'FD' PID04 - code from Metal Composition table PID05 - Not used	For Metal Composition not defined in the code list. <u>Example: 18/2</u> PID01 - 'X' PID02 - '84' PID03 - 'FD' PID04 - GM04MTLC99 PID05 - 18/2

Attribute	EDI Data Mapping	Comments
Metal Feet	YNQ at Detail 0450 YNQ01 – not used YNQ02 – ‘Y’ or ‘N’ YNQ10 – ‘METAL_FEET’	
Microwave Safe	YNQ at Detail 0450 YNQ01 – not used YNQ02 – ‘Y’ or ‘N’ YNQ10 – ‘MICROWAVE_SAFE’	
Minimum Order Quantity	CTB at Detail 0600 CTB01 – ‘OR’ CTB02 – not used CTB03 – ‘57’ CTB04 – minimum order quantity value	
Necklace Type	PID at Detail 0700 PID01 – ‘S’ PID02 – ‘84’ PID03 – ‘FD’ PID04 – code from Necklace Type table PID05 – Not used	For Necklace Type defined in the code list. <u>Example:</u> OPERA PID01 – ‘X’ PID02 – ‘84’ PID03 – ‘FD’ PID04 – JW04NKLC99 PID05 – OPERA
Neckwear Type	PID at Detail 0700 PID01 – ‘S’ PID02 – ‘84’ PID03 – ‘FD’ PID04 – code from Neckwear Type table PID05 – Not used	For Neckwear Type not defined in the code list. <u>Example:</u> KERCHIEF PID01 – ‘X’ PID02 – ‘84’ PID03 – ‘FD’ PID04 – GM04NECK99 PID05 – KERCHIEF
Number of Settings	PID at Detail 0700 PID01 – ‘S’ PID02 – ‘84’ PID03 – ‘FD’ PID04 – code from Number of Settings table PID05 – Not used	For Number of Settings not defined in the code list. <u>Example:</u> SIXTEEN PID01 – ‘X’ PID02 – ‘84’ PID03 – ‘FD’ PID04 – GM04SETS99 PID05 – SIXTEEN
Occasion	PID at Detail 0700 PID01 – ‘S’ PID02 – ‘84’ PID03 – ‘FD’ PID04 – code from Occasion table PID05 – Not used	For Occasion not defined in the code list. <u>Example:</u> MARDI GRAS PID01 – ‘X’ PID02 – ‘84’ PID03 – ‘FD’ PID04 – GM04OCCN99 PID05 – MARDI GRAS



Attribute	EDI Data Mapping	Comments
Officially Licensed	YNQ at Detail 0450 YNQ01 – not used YNQ02 – ‘Y’ or ‘N’ YNQ10 – ‘OFFICIALLY_LICENSED’	
Oil Free	YNQ at Detail 0450 YNQ01 – not used YNQ02 – ‘Y’ or ‘N’ YNQ10 – ‘OIL_FREE’	
Open/Closed Toe	PID at Detail 0700 PID01 – ‘S’ PID02 – ‘84’ PID03 – ‘FD’ PID04 – code from Open/Closed Toe table PID05 – Not used	
Order Quantity Multiple	CTB at Detail 0600 CTB01 – ‘OR’ CTB02 – not used CTB03 – ‘AP’ CTB04 – order quantity multiple value	
Outsole Type	PID at Detail 0700 PID01 – ‘S’ PID02 – ‘84’ PID03 – ‘FD’ PID04 – code from Outsole Type table PID05 – Not used	For Outsole Type not defined in the code list. <u>Example:</u> CREPE PID01 – ‘X’ PID02 – ‘84’ PID03 – ‘FD’ PID04 – GM04OUTS99 PID05 – CREPE
Padded	YNQ at Detail 0450 YNQ01 – not used YNQ02 – ‘Y’ or ‘N’ YNQ10 – ‘PADDED’	
Pant/Inseam Length	MEA at Detail 0800 MEA01 – ‘PD’ MEA02 – ‘LG’ MEA03 – measurement value MEA04 – unit of measure code	
Pants/Shorts Type	PID at Detail 0700 PID01 – ‘S’ PID02 – ‘84’ PID03 – ‘FD’ PID04 – code from Pants/Shorts Type table PID05 – Not used	For Pants/Shorts Type not defined in the code list. <u>Example:</u> JODHPUR PID01 – ‘X’ PID02 – ‘84’ PID03 – ‘FD’ PID04 – GM04PTSH99 PID05 – JODHPUR

Attribute	EDI Data Mapping	Comments
Panty Back Coverage	PID at Detail 0700 PID01 - 'S' PID02 - '84' PID03 - 'FD' PID04 - code from Panty Back Coverage table PID05 - Not used	For Primary Detail Size not defined in the code list. <u>Example: MODERATE</u> PID01 - 'X' PID02 - '84' PID03 - 'FD' PID04 - ++++++ PID05 - MODERATE
Panty Type	PID at Detail 0700 PID01 - 'S' PID02 - '84' PID03 - 'FD' PID04 - code from Panty Type table PID05 - Not used	For Primary Detail Size not defined in the code list. <u>Example: BLOOMERS</u> PID01 - 'X' PID02 - '84' PID03 - 'FD' PID04 - ++++++ PID05 - BLOOMERS
Platform Height	MEA at Detail 0800 MEA01 - 'PD' MEA02 - 'LO' MEA03 - measurement value MEA04 - unit of measure code	
Player Name	PID at Detail 0700 PID01 - 'X' PID02 - '84' PID03 - 'FD' PID04 - GM04PLNM99 PID05 - Gordie Howe	
Pocket Details	PID at Detail 0700 PID01 - 'X' PID02 - '84' PID03 - 'FD' PID04 - GM04PODE99 PID05 - Overstitched	
Primary Detail Application	PID at Detail 0700 PID01 - 'S' PID02 - '84' PID03 - 'FD' PID04 - code from Primary Detail Application table PID05 - Not used	For Primary Detail Application not defined in the code list. <u>Example: SEWN</u> PID01 - 'X' PID02 - '84' PID03 - 'FD' PID04 - GM04PDAP99 PID05 - SEWN
Primary Detail Logo	YNQ at Detail 0450 YNQ01 - not used YNQ02 - 'Y' or 'N' YNQ10 - 'PRIMARY_DETAIL_LOGO'	



Attribute	EDI Data Mapping	Comments
Primary Detail Placement	PID at Detail 0700 PID01 - 'S' PID02 - '84' PID03 - 'FD' PID04 - code from Primary Detail Placement table PID05 - Not used	For Primary Detail Placement defined in the code list. <u>Example:</u> <i>INTERIOR POCKET</i> PID01 - 'X' PID02 - '84' PID03 - 'FD' PID04 - GM04PDPL99 PID05 - INTERIOR POCKET
Primary Detail Size	PID at Detail 0700 PID01 - 'S' PID02 - '84' PID03 - 'FD' PID04 - code from Primary Detail Size table PID05 - Not used	For Primary Detail Size not defined in the code list. <u>Example:</u> <i>GIGANTIC</i> PID01 - 'X' PID02 - '84' PID03 - 'FD' PID04 - GM04PDSZ9 PID05 - GIGANTIC
Primary Detail Type	PID at Detail 0700 PID01 - 'S' PID02 - '84' PID03 - 'FD' PID04 - code from Primary Detail Type table PID05 - Not used	For Primary Detail Type not defined in the code list. <u>Example:</u> <i>COPYRIGHT</i> PID01 - 'X' PID02 - '84' PID03 - 'FD' PID04 - GM04PDTP99 PID05 - COPYRIGHT
Primary Motif Theme	PID at Detail 0700 PID01 - 'S' PID02 - '84' PID03 - 'FD' PID04 - code from Primary Motif Theme table PID05 - Not used	For Primary Motif Theme not defined in the code list. <u>Example:</u> <i>HOBBY</i> PID01 - 'X' PID02 - '84' PID03 - 'FD' PID04 - GM04PMTT99 PID05 - HOBBY
Product	LIN SEGMENT at Detail 0100 LIN01 - Assigned ID Pick an iteration of data element 235/234 pair from LIN04-LIN30 Send VA or VN, followed by the 20-digit Product (Style) ID Number.	Example: LIN*1*VA*53467
Product Description	PID at Detail 0700 PID01 - 'F' PID02 - '08' PID05 - product description	

Attribute	EDI Data Mapping	Comments
Prop 65	YNQ at Detail 0450 YNQ01 – not used YNQ02 – ‘Y’ or ‘N’ YNQ10 – ‘PROP_65’ If Y is indicated in the YNQ for Prop 65, include MTX segment: MTX01-CBA (Statement Related to Regulation) MTX02-Text of the warning (4096 Char max) MTX03-Text of the warning (4096 Char max) MTX04-EN (English)	
Raw Materials Certifications	PID at Detail 0700 PID01 – ‘S’ PID02 – ‘84’ PID03 – ‘FD’ PID04 – code from Raw Materials Certifications Code List PID05 – Not used	For Raw Materials Certifications not defined in the code list. <u>Example:</u> Other Organic cotton PID01 – ‘X’ PID02 – ‘84’ PID03 – ‘FD’ PID04 – GM04RAMA99 PID05 – OTHER ORANIC COTTON
Refillable	YNQ at Detail 0450 YNQ01 – not used YNQ02 – ‘Y’ or ‘N’ YNQ10 – ‘REFILLABLE’	
Re-orderable	YNQ at Detail 0450 YNQ01 – not used YNQ02 – ‘Y’ or ‘N’ YNQ10 – ‘REORDERABLE’	
Responsible Manufacturing	YNQ at Detail 0450 YNQ01 – not used YNQ02 – ‘Y’ or ‘N’ YNQ10 – ‘RESPONSIBLE MANUFACTURING’ If Y is indicated in the YNQ for Responsible Manufacturing, include MTX segment: MTX01 RMA MTX02-Text (4096 Char max) MTX03-Text (4096 Char max) MTX04-EN (English)	
Reversible	YNQ at Detail 0450 YNQ01 – not used YNQ02 – ‘Y’ or ‘N’ YNQ10 – ‘REVERSIBLE’	

Attribute	EDI Data Mapping	Comments
Ring Type	PID at Detail 0700 PID01 - 'S' PID02 - '84' PID03 - 'FD' PID04 - code from Ring Type table PID05 - Not used	For Ring Type not defined in the code list. <u>Example:</u> <i>RIGHT HAND</i> PID01 - 'X' PID02 - '84' PID03 - 'FD' PID04 - JW04RING99 PID05 - RIGHT HAND
Rug Type	PID at Detail 0700 PID01 - 'S' PID02 - '84' PID03 - 'FD' PID04 - code from Rug Type table PID05 - Not used	For Rug Type not defined in the code list. <u>Example:</u> <i>THROW</i> PID01 - 'X' PID02 - '84' PID03 - 'FD' PID04 - GM04RUGT99 PID05 - THROW
Scarf Type	PID at Detail 0700 PID01 - 'S' PID02 - '84' PID03 - 'FD' PID04 - code from Scarf Type table PID05 - Not used	For Scarf Type not defined in the code list. <u>Example:</u> <i>WINTER</i> PID01 - 'X' PID02 - '84' PID03 - 'FD' PID04 - GM04SCTY99 PID05 - WINTER
Scent Type	PID at Detail 0700 PID01 - 'S' PID02 - '84' PID03 - 'FD' PID04 - code from Scent Type table PID05 - Not used	For Scent Type not defined in the code list. <u>Example:</u> <i>FOUGERE</i> PID01 - 'X' PID02 - '84' PID03 - 'FD' PID04 - GM04SCTP99 PID05 - FOUGERE
Seams	PID at Detail 0700 PID01 - 'S' PID02 - '84' PID03 - 'FD' PID04 - code from Seams table PID05 - Not used	For Seams not defined in the code list. <u>Example:</u> <i>SEMI FLAT</i> PID01 - 'X' PID02 - '84' PID03 - 'FD' PID04 - IA04SEAM99 PID05 - SEMI FLAT

Attribute	EDI Data Mapping	Comments
Secondary Detail Application	PID at Detail 0700 PID01 – 'S' PID02 – '84' PID03 – 'FD' PID04 – code from Secondary Detail Application table PID05 – Not used	For Secondary Detail Application not defined in the code list. <u>Example:</u> <i>SEWN</i> PID01 – 'X' PID02 – '84' PID03 – 'FD' PID04 – GM04SDAP99 PID05 – SEWN
Secondary Detail Logo	YNQ at Detail 0450 YNQ01 – not used YNQ02 – 'Y' or 'N' YNQ10 – 'SECONDARY_DETAIL_LOGO'	
Secondary Detail Placement	PID at Detail 0700 PID01 – 'S' PID02 – '84' PID03 – 'FD' PID04 – code from Secondary Detail Placement table PID05 – Not used	For Secondary Detail Placement defined in the code list. <u>Example:</u> <i>INTERIOR POCKET</i> PID01 – 'X' PID02 – '84' PID03 – 'FD' PID04 – GM04SDPL99 PID05 – INTERIOR POCKET
Secondary Detail Size	PID at Detail 0700 PID01 – 'S' PID02 – '84' PID03 – 'FD' PID04 – code from Secondary Detail Size table PID05 – Not used	For Secondary Detail Size not defined in the code list. <u>Example:</u> <i>GIGANTIC</i> PID01 – 'X' PID02 – '84' PID03 – 'FD' PID04 – GM04SDSZ9 PID05 – GIGANTIC
Secondary Detail Type	PID at Detail 0700 PID01 – 'S' PID02 – '84' PID03 – 'FD' PID04 – code from Secondary Detail Type table PID05 – Not used	For Secondary Detail Type not defined in the code list. <u>Example:</u> <i>COPYRIGHT</i> PID01 – 'X' PID02 – '84' PID03 – 'FD' PID04 – GM04SDTP99 PID05 – COPYRIGHT
Secondary Motif Theme	PID at Detail 0700 PID01 – 'S' PID02 – '84' PID03 – 'FD' PID04 – code from Secondary Motif Theme table PID05 – Not used	For Secondary Motif Theme not defined in the code list. <u>Example:</u> <i>HOBBY</i> PID01 – 'X' PID02 – '84' PID03 – 'FD' PID04 – GM04SMTT99 PID05 – HOBBY



Attribute	EDI Data Mapping	Comments
Selling Channel	PID at Detail 0700 PID01 - 'S' PID02 - '84' PID03 - 'FD' PID04 - code from Selling Channel table PID05 - Not used	For Selling Channel not defined in the code list. <u>Example:</u> <i>MOBILE</i> PID01 - 'X' PID02 - '84' PID03 - 'FD' PID04 - ZZ04SELC99 PID05 - MOBILE
Shape	PID at Detail 0700 PID01 - 'S' PID02 - '84' PID03 - 'FD' PID04 - code from Shape table PID05 - Not used	For Shape not defined in the code list. <u>EXAMPLE:</u> <i>OCTAGONAL</i> PID01 - 'X' PID02 - '84' PID03 - 'FD' PID04 - GM04SHPE99 PID05 - OCTAGONAL
Shapewear Type	PID at Detail 0700 PID01 - 'S' PID02 - '84' PID03 - 'FD' PID04 - code from Shapewear Type table PID05 - Not used	For Shape not defined in the code list. <u>EXAMPLE:</u> <i>GIRDLE</i> PID01 - 'X' PID02 - '84' PID03 - 'FD' PID04 - ++++++ PID05- GIRDLE
Shippable Package/Carton	YNQ at Detail 0450 YNQ01 - not used YNQ02 - 'Y' or 'N' YNQ10 - 'SHIPPABLE_PACKAGE'	
Shoe Style	PID at Detail 0700 PID01 - 'S' PID02 - '84' PID03 - 'FD' PID04 - code from Shoe Style table PID05 - Not used	For Shoe Style not defined in the code list. <u>Example:</u> <i>SNAKE BOOT</i> PID01 - 'X' PID02 - '84' PID03 - 'FD' PID04 - GM04SHOE99 PID05 - SNAKE BOOT
Shoe Type	PID at Detail 0700 PID01 - 'S' PID02 - '84' PID03 - 'FD' PID04 - code from Shoe Type table PID05 - Not used	For Shoe Type not defined in the code list. <u>Example:</u> <i>ORTHOPEDIC</i> PID01 - 'X' PID02 - '84' PID03 - 'FD' PID04 - GM04SETP99 PID05 - ORTHOPEDIC



Attribute	EDI Data Mapping	Comments
Size Code - GS1 US	LIN SEGMENT at Detail 0100 LIN01 – Assigned ID Pick an iteration of data element 235/234 pair from LIN04-LIN30 Send SM followed by the 5-digit GS1 US Size Code	Example: LIN*1*SM*30902
Size Description	PID at Detail 0700 PID01 – 'F' PID02 – '74' PID05 – size description	
Skin Type	PID at Detail 0700 PID01 – 'S' PID02 – '84' PID03 – 'FD' PID04 – code from Skin Type table PID05 – Not used	For Skin Type not defined in the code list. <u>Example:</u> <i>VERY DRY</i> PID01 – 'X' PID02 – '84' PID03 – 'FD' PID04 – GM04SKTP99 PID05 – VERY DRY
Skirt Type	PID at Detail 0700 PID01 – 'S' PID02 – '84' PID03 – 'FD' PID04 – code from Skirt Type table PID05 – Not used	For Closure not defined in the code list. <u>Example:</u> <i>BROOMSTICK</i> PID01 – 'X' PID02 – '84' PID03 – 'FD' PID04 – GM04SKRT99 PID05 – BROOMSTICK
Sleepwear Type	PID at Detail 0700 PID01 – 'S' PID02 – '84' PID03 – 'FD' PID04 – code from Sleepwear Type table PID05 – Not used	For Closure not defined in the code list. <u>Example:</u> <i>OTHER</i> PID01 – 'X' PID02 – '84' PID03 – 'FD' PID04 – +++++++ PID05 – OTHER
Sleeve Measurement	MEA at Detail 0800 MEA01 – 'PD' MEA02 – 'TR' MEA03 – measurement value MEA04 – unit of measure code	

Attribute	EDI Data Mapping	Comments
Sleeve Type	PID at Detail 0700 PID01 - 'S' PID02 - '84' PID03 - 'FD' PID04 - code from Sleeve Type table PID05 - Not used; <i>see Comments</i> <u>Example: Cap</u> PID at Detail 0700 PID01 - 'S' PID02 - '84' PID03 - 'FD' PID04 - GM03SLVTCS PID05 - Not used	For Sleeve Type not defined in the code list. <u>Example: HALF CAP</u> PID01 - 'X' PID02 - '84' PID03 - 'FD' PID04 - GM04SLVT99 PID05 - HALF CAP
Slip Split	YNQ at Detail 0450 YNQ01 - not used YNQ02 - 'Y' or 'N' YNQ10 - 'SLIP SPLIT'	
Slip Type	PID at Detail 0700 PID01 - 'S' PID02 - '84' PID03 - 'FD' PID04 - code from Slip Type table PID05 - Not used	For Closure not defined in the code list. <u>Example: MICROMINI</u> PID01 - 'X' PID02 - '84' PID03 - 'FD' PID04 - ++++++ PID05 - MICROMINI
Social Certifications	PID at Detail 0700 PID01 - 'S' PID02 - '84' PID03 - 'FD' PID04 - code from Social Certifications Code List PID05 - Not used	For Social Certifications not defined in the code list. <u>Example: OTHER</u> PID01 - 'X' PID02 - '84' PID03 - 'FD' PID04 - GM04SOCE99 PID05 - OTHER
Sole Type	PID at Detail 0700 PID01 - 'S' PID02 - '84' PID03 - 'FD' PID04 - code from Sole Type table PID05 - Not used; <i>See Comments</i> <u>Example: Leather</u> PID at Detail 0700 PID01 - 'S' PID02 - '84' PID03 - 'FD' PID04 - GM03SOLTLS PID05 - Not used	For Sole Type not defined in the code list. <u>Example: PLASTIC</u> PID01 - 'X' PID02 - '84' PID03 - 'FD' PID04 - GM04SOLT99 PID05 - PLASTIC



Attribute	EDI Data Mapping	Comments
Special Embellishment	PID at Detail 0700 PID01 - 'S' PID02 - '84' PID03 - 'FD' PID04 - code from Special Embellishment table PID05 - Not used	For Special Embellishment not defined in the code list. <u>Example: FAIRY DUST</u> PID01 - 'X' PID02 - '84' PID03 - 'FD' PID04 - GM04SPEM99 PID05 - FAIRY DUST
Special Handling Code	TD4 at Detail 1100 TD401 - select from X12 code list	
Special Item Code	PID at Detail 0700 PID01 - 'S' PID02 - not used PID03 - 'VI' PID04 - select a code value 'GW' - Gift with Purchase 'PW' - Purchase with Purchase 'CL' - Collateral	
SPF Rating	PID at Detail 0700 PID01 - 'S' PID02 - '84' PID03 - 'FD' PID04 - code from SPF Rating table PID05 - Not used	For SPF Rating not defined in the code list. <u>Example: 45</u> PID01 - 'X' PID02 - '84' PID03 - 'FD' PID04 - GM04SPFR99 PID05 - 45
Sport	PID at Detail 0700 PID01 - 'S' PID02 - '84' PID03 - 'FD' PID04 - code from Sport table PID05 - Not used	For Sport not defined in the code list. <u>Example: PICKLEBALL</u> PID01 - 'X' PID02 - '84' PID03 - 'FD' PID04 - ZZ04SPRT99 PID05 - PICKLEBALL
Stay Cool Handle	YNQ at Detail 0450 YNQ01 - not used YNQ02 - 'Y' or 'N' YNQ10 - 'STAY_COOL_HANDLE'	
Steamable	YNQ at Detail 0450 YNQ01 - not used YNQ02 - 'Y' or 'N' YNQ10 - 'STEAMABLE'	



Attribute	EDI Data Mapping	Comments
Stone Details	PID at Detail 0700 PID01 - 'X' PID02 - '84' PID03 - 'AS' PID04 - 'STONE' PID05 - name/description of stone(s)	
Strap Placement	PID at Detail 0700 PID01 - 'S' PID02 - '84' PID03 - 'FD' PID04 - code from Strap Placement table PID05 - Not used	For Strap Placement not defined in the code list. <u>Example: OFFSET</u> PID01 - 'X' PID02 - '84' PID03 - 'FD' PID04 - GM03STPL99 PID05 - OFFSET
Stretch	YNQ at Detail 0450 YNQ01 - not used YNQ02 - 'Y' or 'N' YNQ10 - 'STRETCH'	
Supplier Suggested Retail Price	CTP Loop at Detail 1700 CTP01 - 'RS' CTP02 - 'MSR' CTP03 - suggested retail price	
Supplemental Circularity Certifications	PID at Detail 0700 PID01 - 'S' PID02 - '84' PID03 - 'FD' PID04 - code from Supplemental Circularity Certification code list PID05 - Not used	For Supplemental Circularity Certifications not defined in the code list. <u>Example: OTHER</u> PID01 - 'X' PID02 - '84' PID03 - 'FD' PID04 - GM04SUC99 PID05 - OTHER
Supplemental Corporate/Philanthropic Certifications	PID at Detail 0700 PID01 - 'S' PID02 - '84' PID03 - 'FD' PID04 - code from Supplemental Corporate/Philanthropic Certifications code list PID05 - Not used	For Supplemental Corporate/Philanthropic not defined in the code list. <u>Example: OTHER</u> PID01 - 'X' PID02 - '84' PID03 - 'FD' PID04 - GM04SCOP99 PID05 - OTHER



Attribute	EDI Data Mapping	Comments
Supplemental Packaging Certifications	PID at Detail 0700 PID01 - 'S' PID02 - '84' PID03 - 'FD' PID04 - code from Supplemental Packaging certifications table PID05 - Not used	For Supplemental Packaging Certifications not defined in the code list. <u>Example:</u> OTHER PID01 - 'X' PID02 - '84' PID03 - 'FD' PID04 - GM04SPEC99 PID05 - OTHER
Supplemental Traceability Programs	PID at Detail 0700 PID01 - 'S' PID02 - '84' PID03 - 'FD' PID04 - code from Supplemental Traceability Programs PID05 - Not used	For Supplemental Traceability Programs not defined in code list <u>Example:</u> OTHER PID01 - 'X' PID02 - '84' PID03 - 'FD' PID04 - GM04SUTR99 PID05 - OTHER
Supplemental Raw Materials Certifications	PID at Detail 0700 PID01 - 'S' PID02 - '84' PID03 - 'FD' PID04 - code from Supplemental Raw Materials table PID05 - Not used	For Supplemental Raw Materials not defined in the code list. <u>Example:</u> OTHER PID01 - 'X' PID02 - '84' PID03 - 'FD' PID04 - GM04SRMC99 PID05 - OTHER
Supplier Wholesale Price	CTP Loop at Detail 1700 CTP01 - 'WH' CTP02 - 'UCP' CTP03 - supplier wholesale price	
Supply Type	PID at Detail 0700 PID01 - 'S' PID02 - '84' PID03 - 'FD' PID04 - code from Supply Type table PID05 - Not used	For Supply Type not defined in the code list. <u>Example:</u> INTERMITTENTLY PID01 - 'X' PID02 - '84' PID03 - 'FD' PID04 - ZZ04SUTY99 PID05 - INTERMITTENTLY
Support Level	PID at Detail 0700 PID01 - 'S' PID02 - '84' PID03 - 'FD' PID04 - code from Support Level table PID05 - Not used	For Support Level not defined in the code list. <u>Example:</u> COMPRESSION PID01 - 'X' PID02 - '84' PID03 - 'FD' PID04 - GM03SULV99 PID05 - COMPRESSION

Attribute	EDI Data Mapping	Comments
Sustainable Materials	YNQ at Detail 0450 YNQ01 – not used YNQ02 – ‘Y’ or ‘N’ YNQ10 – ‘SUSTAINABLE MATERIALS’ If Y is indicated in the YNQ for Sustainable Materials, include MTX segment: MTX01- SMA MTX02 -Text (4096 Char max) MTX03 -Text (4096 Char max) MTX04 -EN (English)	
Sustainable Packaging	YNQ at Detail 0450 YNQ01 – not used YNQ02 – ‘Y’ or ‘N’ YNQ10 – ‘SUSTAINABLE PACKAGING’ If Y is indicated in the YNQ for Sustainable Packaging, include MTX segment: MTX01- SPA MTX02-Text (4096 Char max) MTX03-Text (4096 Char max) MTX04-EN (English)	
Sweater/Pullover Type	PID at Detail 0700 PID01 – ‘S’ PID02 – ‘84’ PID03 – ‘FD’ PID04 – code from Sweater/Pullover Type table PID05 – Not used	For Sweater/Pullover Type not defined in the code list. <u>Example:</u> <i>SWEATERVEST</i> PID01 – ‘X’ PID02 – ‘84’ PID03 – ‘FD’ PID04 – GM04SWPU99 PID05 – SWEATERVEST
Swim Bottom Type	PID at Detail 0700 PID01 – ‘S’ PID02 – ‘84’ PID03 – ‘FD’ PID04 – code from Swim Bottom Type table PID05 – Not used	For Swim Bottom Type not defined in the code list. <u>Example:</u> <i>LONG SHORT</i> PID01 – ‘X’ PID02 – ‘84’ PID03 – ‘FD’ PID04 – GM04SWBT99 PID05 – LONG SHORT
Swim Cover-up Type	PID at Detail 0700 PID01 – ‘S’ PID02 – ‘84’ PID03 – ‘FD’ PID04 – code from Swim Cover-up Type table PID05 – Not used	For Swim Cover-up Type not defined in the code list. <u>Example:</u> <i>MAXI DRESS</i> PID01 – ‘X’ PID02 – ‘84’ PID03 – ‘FD’ PID04 – GM04SWCT99 PID05 – MAXI DRESS

Attribute	EDI Data Mapping	Comments
Swim One-Piece Type	PID at Detail 0700 PID01 - 'S' PID02 - '84' PID03 - 'FD' PID04 - code from Swim One-piece Type table PID05 - Not used	For Swim One-piece Type not defined in the code list. <u>Example:</u> <i>SPORT</i> PID01 - 'X' PID02 - '84' PID03 - 'FD' PID04 - GM04SWOT99 PID05 - SPORT
Swim Top Type	PID at Detail 0700 PID01 - 'S' PID02 - '84' PID03 - 'FD' PID04 - code from Swim Top Type table PID05 - Not used	For Swim Top Type not defined in the code list. <u>Example:</u> <i>BLOUSON</i> PID01 - 'X' PID02 - '84' PID03 - 'FD' PID04 - GM04SWTT99 PID05 - BLOUSON
Tableware Type	PID at Detail 0700 PID01 - 'S' PID02 - '84' PID03 - 'FD' PID04 - code from Tableware Type table PID05 - Not used	For Tableware not defined in the code list. <u>Example:</u> <i>SERVEWARE</i> PID01 - 'X' PID02 - '84' PID03 - 'FD' PID04 - GM04TBLT99 PID05 - SERVEWARE
Tag	YNQ at Detail 0450 YNQ01 - not used YNQ02 - 'Y' or 'N' YNQ10 - 'TAG'	
Team Name	PID at Detail 0700 PID01 - 'X' PID02 - '84' PID03 - 'AS' PID04 - 'TEAM' PID05 - team name	
Third Detail Application	PID at Detail 0700 PID01 - 'S' PID02 - '84' PID03 - 'FD' PID04 - code from Third Detail Application table PID05 - Not used	For Third Detail Application not defined in the code list. <u>Example:</u> <i>SEWN</i> PID01 - 'X' PID02 - '84' PID03 - 'FD' PID04 - GM04TDAP99 PID05 - SEWN
Third Detail Logo	YNQ at Detail 0450 YNQ01 - not used YNQ02 - 'Y' or 'N' YNQ10 - 'THIRD_DETAIL_LOGO'	



Attribute	EDI Data Mapping	Comments
Third Detail Placement	PID at Detail 0700 PID01 - 'S' PID02 - '84' PID03 - 'FD' PID04 - code from Third Detail Placement table PID05 - Not used	For Third Detail Placement defined in the code list. <u>Example:</u> <i>INTERIOR POCKET</i> PID01 - 'X' PID02 - '84' PID03 - 'FD' PID04 - GM04TDPL99 PID05 - INTERIOR POCKET
Third Detail Size	PID at Detail 0700 PID01 - 'S' PID02 - '84' PID03 - 'FD' PID04 - code from Third Detail Size table PID05 - Not used	For Third Detail Size not defined in the code list. <u>Example:</u> <i>GIGANTIC</i> PID01 - 'X' PID02 - '84' PID03 - 'FD' PID04 - GM04TDSZ9 PID05 - GIGANTIC
Third Detail Type	PID at Detail 0700 PID01 - 'S' PID02 - '84' PID03 - 'FD' PID04 - code from Third Detail Type table PID05 - Not used	For Third Detail Type not defined in the code list. <u>Example:</u> <i>COPYRIGHT</i> PID01 - 'X' PID02 - '84' PID03 - 'FD' PID04 - GM04TDTP99 PID05 - COPYRIGHT
Third Motif Theme	PID at Detail 0700 PID01 - 'S' PID02 - '84' PID03 - 'FD' PID04 - code from Third Motif Theme table PID05 - Not used	For Third Motif Theme not defined in the code list. <u>Example:</u> <i>HOBBY</i> PID01 - 'X' PID02 - '84' PID03 - 'FD' PID04 - GM04TMTT99 PID05 - HOBBY
Toe Shape/Style	PID at Detail 0700 PID01 - 'S' PID02 - '84' PID03 - 'FD' PID04 - code from Toe Shape table PID05 - Not used	For Toe Shape not defined in the code list. <u>Example:</u> <i>NATURAL</i> PID01 - 'X' PID02 - '84' PID03 - 'FD' PID04 - M04TOES99 PID05 - NATURAL

Attribute	EDI Data Mapping	Comments
Toe Style	PID at Detail 0700 PID01 - 'S' PID02 - '84' PID03 - 'FD' PID04 - code from Toe Style table PID05 - Not used	For Toe Style not defined in the code list. <u>Example:</u> <i>NATURAL</i> PID01 - 'X' PID02 - '84' PID03 - 'FD' PID04 - M04TOEY99 PID05 - NATURAL
Towel Type	PID at Detail 0700 PID01 - 'S' PID02 - '84' PID03 - 'FD' PID04 - code from Towel Type table PID05 - Not used	For Towel Type not defined in the code list. <u>Example:</u> <i>FINGERTIP</i> PID01 - 'X' PID02 - '84' PID03 - 'FD' PID04 - GM04TOWL99 PID05 - FINGERTIP
Vendor Collection Name	PID at Detail 0700 PID01 - 'F' PID02 - 'BRG' PID03 - not used PID04 - not used PID05 - collection name	
Waist Rise	PID at Detail 0700 PID01 - 'S' PID02 - '84' PID03 - 'FD' PID04 - code from Waist Rise table PID05 - Not used	For Waist Rise not defined in the code list. <u>Example:</u> <i>ERKELESQUE</i> PID01 - 'X' PID02 - '84' PID03 - 'FD' PID04 - GM04WSDR99 PID05 - ERKELESQUE
Waistband Type	PID at Detail 0700 PID01 - 'S' PID02 - '84' PID03 - 'FD' PID04 - code from Waistband Type table PID05 - Not used	For Waistband Type not defined in the code list. <u>Example:</u> <i>INSET</i> PID01 - 'X' PID02 - '84' PID03 - 'FD' PID04 - GM04WBTP99 PID05 - INSET
Warranty Description	MTX at Detail 1670 MTX01 - 'WAR' MTX02 - warranty description MTX03 - warranty description	

Attribute	EDI Data Mapping	Comments
Watch Band Width	MEA at Detail 0800 MEA01 – ‘PS’ MEA02 – ‘WD’ MEA03 – measurement value MEA04 – unit of measure code	
Watch Case Shape	PID at Detail 0700 PID01 – ‘S’ PID02 – ‘84’ PID03 – ‘FD’ PID04 – code from Watch Case Shape table PID05 – Not used	For Watch Case Shape not defined in the code list. <u>Example:</u> <i>HEXAGON</i> PID01 – ‘X’ PID02 – ‘84’ PID03 – ‘FD’ PID04 – JW04WACS99 PID05 – HEXAGON
Watch Case Size	MEA at Detail 0800 MEA01 – ‘PD’ MEA02 – ‘DI’ MEA02 – ‘HT’ MEA02 – ‘WD’ MEA03 – measurement value MEA04 – unit of measure code	Use MEA02 DI for diameter if watch case is round or use MEA02 HT and MEA02WD for a square or rectangular watch case.
Water Repellent	PID at Detail 0700 PID01 – ‘S’ PID02 – ‘84’ PID03 – ‘FD’ PID04 – code from Water Repellent table PID05 – Not used	For Water Repellent value not defined in the code list. <u>Example:</u> <i>OTHER</i> PID01 – ‘X’ PID02 – ‘84’ PID03 – ‘FD’ PID04 – ZZ04WATR99 PID05 – OTHER
Wrinkle Resistant	YNQ at Detail 0450 YNQ01 – not used YNQ02 – ‘Y’ or ‘N’ YNQ10 – ‘WRINKLE_RESISTANT’	

3.9 GS1 US Standard Spreadsheet for Product Information Exchange

A standard spreadsheet for exchanging attributes between trading partners has been developed by GS1 US. More information and sample spreadsheets may be found on the GS1 US website at [GS1 US Apparel and General Merchandise Attribute Template](#).

4 Resources

4.1 Links to ISO Country Code Information

For more information on ISO country codes refer to the following websites

- ISO Website: www.iso.org/iso/country_codes
- Wikipedia: en.wikipedia.org/wiki/ISO_3166-1

4.2 Link to GS1 Product Image Specification Standard

Website: http://www.gs1.org/sites/default/files/docs/gdsn/Product_Image_Specification.pdf

4.3 Glossary

Term	Definition
1.5/06/660	<p>Notation example of how to express barcode print quality to a barcode printer/provider:</p> <ul style="list-style-type: none"> ■ "1.5" represents the minimum print quality ISO grade (C) ■ "06" represents the barcode verifier light aperture and represents the dimension of ".006" ■ "660" is the wavelength in nanometers of light to be used when testing the barcode- 660 is red light
BHT	<p>Butylated hydroxytoluene (also known as dibutylhydroxytoluene) is a lipophilic organic compound, chemically a derivative of phenol that is useful for its antioxidant properties commonly used to preserve foods and cosmetics to slow down the autoxidation rate of ingredients in a product that can cause changes in the taste or color. There have been many studies which demonstrate that BHT accumulates over time in the body, having a toxic impact on the lungs, liver, and kidneys amongst other negative effects.</p>
EPC	<p>Electronic Product Code</p>
HRI	<p>Human Readable Interpretation: Characters, such as letters and numbers, which can be read by persons and are encoded in GS1 AIDC data carriers confined to a GS1 Standard structure and format. The Human Readable Interpretation is a one-to-one illustration of the encoded data. However, start, stop, shift, and function characters, as well as the Symbol Check Character, are not shown in the HRI.</p>
Mil	<p>Unit of measure used in North America to identify material thickness or barcode bar width. One mil equals one thousandth of an inch (.001"). Does not relate to, or mean millimeters.</p>
Multi-pack	<p>A multi-pack is a group of trade items (the same or different) that are intended to be sold as a single consumer unit at the Point of Sale (e.g., a three pack of men's white T-shirts or a 12-piece set of glassware). A multi-pack is not intended to be broken apart and sold as individual trade items. A multi-pack is assigned a GTIN that is different from the GTIN that may be assigned to the individual trade items. Generally, components of a multi-pack are not marked with the individual trade item GTINs. Each different multi-pack of the same trade items (e.g., three-pack socks versus six-pack socks) must have a different GTIN assigned. Each different multi-pack GTIN must also have its own trade item/color ID/size ID.</p>
Pre-pack	<p>A pre-pack is an assortment of trade items that is intended to be ordered by the retail buyer as a single line item; however, the individual items within the prepack are intended to be sold separately at the point of sale.</p> <p>For a pre-pack or standard assortment of trade items, each different item within the pre-pack will be assigned a GTIN maintaining the one-to-one relationship between trade item/color ID/size ID and GTIN. Each of the component GTINs is scannable at the Point of Sale and may or may not be orderable separately outside of the prepack. In addition, a separate, unique GTIN is assigned to each orderable prepack. This GTIN is not scannable at the Point of Sale.</p>
RFID	<p>Radio Frequency Identification</p>

Term	Definition
Set-pack	<p>A set-pack is a group of trade items (the same or different) that is intended to be sold as a single consumer unit at Point of Sale; however, alternatively, the group may be separated, and the individual trade items sold individually. The set-pack is identified and marked with a unique GTIN, as are each of the contained trade items, maintaining the one-to-one relationship between trade item/color ID/size ID and the GTIN. Each individual trade item GTIN must be scannable at the Point of Sale and may or may not be orderable, separately outside the set-pack(s). A separate and unique GTIN is assigned to each set-pack. This GTIN is also scannable at Point of Sale.</p> <p>For a set-pack, each different trade item within the set-pack will be assigned a GTIN, maintaining the one-to-one relationship between trade item/color ID/size ID and the GTIN. The individual trade item GTIN must be scannable at the Point of Sale and may or may not be orderable, separately outside the set-pack(s). A separate and unique GTIN is assigned to each set-pack. This GTIN is also scannable at Point of Sale.</p>
Style	<p>A style is a trade item void of any color and size implications. A style number should be assigned to include all sizes and colors. The style number is a seller’s primary identification of a product and a meaningful link to GTINs (individual color/size) for both seller and buyer. For more information, please refer to Section 3.1.3 in the Trade Item Identification and Communication Guidelines for Electronic Data Interchange (TIIC).</p>
Trade Item	<p>Any item (product or service) upon which there is a need to retrieve predefined information and that may be priced, ordered, or invoiced at any point in any supply chain.</p>
UPC/EAN	<p>How the industry refers to the group of “point of sale” barcodes titled by ISO as “the EAN/UPC Symbology.”</p>



Proprietary Statement

This document contains proprietary information of GS1 US. Such proprietary information may not be changed for use with any other parties for any other purpose without the expressed written permission of GS1 US.

Improvements

Improvements and changes are periodically made to publications by GS1 US. All material is subject to change without notice. Please refer to GS1 US website for the most current publication available.

Disclaimer

Except as may be otherwise indicated in specific documents within this publication, you are authorized to view documents within this publication, subject to the following:

1. You agree to retain all copyright and other proprietary notices on every copy you make.
2. Some documents may contain other proprietary notices and copyright information relating to that document. You agree that GS1 US has not conferred by implication, estoppels, or otherwise any license or right under any patent, trademark, or copyright (except as expressly provided above) of GS1 US or of any third party.

This publication is provided "as is" without warranty of any kind, either express or implied, including, but not limited to, the implied warranties of merchantability, fitness for a particular purpose, or non-infringement. Any GS1 US publication may include technical inaccuracies or typographical errors. GS1 US assumes no responsibility for and disclaims all liability for any errors or omissions in this publication or in other documents which are referred to within or linked to this publication. Some jurisdictions do not allow the exclusion of implied warranties, so the above exclusion may not apply to you.

Several products and company names mentioned herein may be trademarks and/or registered trademarks of their respective companies. GS1 US does not, by promulgating this document on behalf of the parties involved in the creation of this document, represent that any methods, products, and/or systems discussed or recommended in the document do not violate the intellectual property rights of any third party. GS1 US has not performed a search to determine what intellectual property may be infringed by an implementation of any strategies or suggestions included in this document. GS1 US hereby disclaims any liability for any party's infringement of intellectual property rights that arise as a result of any implementation of strategies or suggestions included in this document.

This publication may be distributed internationally and may contain references to GS1 US products, programs, and services that have not been announced in your country. These references do not imply that GS1 US intends to announce such products, programs, or services in your country.

GS1 US shall not be liable for any consequential, special, indirect, incidental, liquidated, exemplary, or punitive damages of any kind or nature whatsoever, or any lost income or profits, under any theory of liability, arising out of the use of this publication or any content herein, even if advised of the possibility of such loss or damage or if such loss or damage could have been reasonably foreseen.

GS1 US HEREBY DISCLAIMS, AND YOU HEREBY EXPRESSLY RELEASE GS1 US FROM, ANY AND ALL LIABILITY RELATING TO YOUR COMPLIANCE WITH REGULATORY STANDARDS AND LAWS, INCLUDING ALL RULES AND REGULATIONS PROMULGATED THEREUNDER. GS1 US MAKES NO WARRANTIES OF ANY KIND RELATING TO THE SUITABILITY OF THE GS1 STANDARDS AND THE SPECIFIC DOCUMENTS WITHIN THIS PUBLICATION TO COMPLY WITH ANY REGULATORY STANDARDS, LAWS, RULES AND REGULATIONS. ALL INFORMATION AND SERVICES ARE PROVIDED "AS IS."

*GS1 US employees are not representatives or agents of the U.S. FDA, and the content of this publication has not been reviewed, approved, or authorized by the U.S. FDA. The following information contained herein is for informational purposes only as a convenience and is not legal advice or a substitute for legal counsel. GS1 US Inc. assumes no liability for the use or interpretation of the information contained herein.

No Liability for Consequential Damage

In no event shall GS1 US or anyone else involved in the creation, production, or delivery of the accompanying documentation be liable for any damages whatsoever (including, without limitation, damages for loss of business profits, business interruption, loss of business information, or other loss) arising out of the use of or the results of use of or inability to use such documentation, even if GS1 US has been advised of the possibility of such damages.

IAPMO

In this publication, the letters "U.P.C." are used solely as an abbreviation for the "Universal Product Code" which is a product identification system. They do not refer to the UPC, which is a federally registered certification mark of the International Association of Plumbing and Mechanical Officials (IAPMO) to certify compliance with a Uniform Plumbing Code as authorized by IAPMO.

*If applicable

GS1 US Corporate Headquarters

Princeton South Corporate Center, 300 Charles Ewing Boulevard
Ewing, NJ 08628 USA

T +1 609.620.0200 | **E** info@gs1us.org

www.gs1us.org

Connect With Us

